

ANGLETON, BAILES (7R9)

UPDATED: 8/25/2015

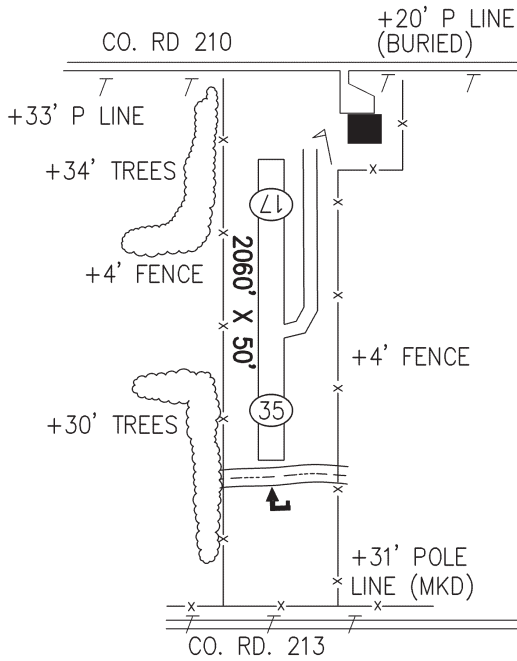

Lat: N 29° 10.00'
Lon: W 95° 24.06'

Elev: 21' MSL
TPA: STD

Sectional: HOUSTON
Downtown to Apt: 02 nm/E

Owner: R L BAILES JR ESTATE
 817 N VALDERAS
 ANGLETON TX 77515
Phone: 979-849-5173

Manager: DANNY STILL
 408 CR 243
 ANGLETON TX 77515
 979-549-6848

ATTENDANCE SCHEDULE: UNATTENDED

FUEL: NONE

REPAIRS: Airframe: MINOR Power Plant: MINOR

LIGHTS: NONE **UNICOM/CTAF:** 122.9

REMARKS: FOOD-LODGING (2MI)

FIXED BASE OPERATORS: NONE

