

# Special Specification 3049

## Squeegee Seal



### 1. DESCRIPTION

Construct a surface treatment consisting of 1 or more applications of a single layer of asphalt emulsion that is scrubbed with a rubber blade or rubber squeegee and covered with a single layer of aggregate.

### 2. MATERIALS

Furnish materials of the type and grade shown on the plans in accordance with the following:

- Polymer modified emulsion that meets the requirements of Item 300, "Asphalts, Oils, and Emulsions" Table 10 CMS-1P.
- Item 302, "Aggregates for Surface Treatments." Clean concrete sand meeting the requirements of Table 10 in Item 421.

### 3. EQUIPMENT

- 3.1. **Distributor.** Furnish a distributor that will apply the emulsion uniformly at the specified rate or as directed.
- 3.1.1. **Calibration.** Furnish a volumetric calibration and strap stick for the distributor tank in accordance with Tex-922-K, Part I. Provide documentation of distributor calibration performed not more than 5 yr. before the date first used on the project. The Engineer may verify calibration accuracy in accordance with Tex-922-K, Part II.
- 3.1.2. **Computerized Distributor.** When paying for emulsion by weight, the Engineer may allow use of the computerized distributor display to verify application rates. Verify application rate accuracy at a frequency acceptable to the Engineer.
- 3.2. **Aggregate Spreader.** Use a continuous-feed, self-propelled spreader to apply aggregate uniformly at the specified rate or as directed.
- 3.3. **Rollers.** Unless otherwise shown on the plans, furnish light pneumatic tire rollers in accordance with Item 210, "Rolling."
- 3.4. **Squeegee Assembly.** Furnish a rubber blade or rubber squeegee assembly of similar design to Exhibit A or B, as approved by the engineer, and having the following characteristics:
- Rigid frame construction,
  - Attached to, and pulled by, the distributor,
  - Of such weight that it does not push the emulsion off the roadway surface,
  - Leading and trailing rubber squeegee or blade heads angled at 10 to 15 degrees off the centerline of the supporting member,
  - Hinged wing assemblies or other means of adjusting the width.
- Provide a means of raising the rubber blade or rubber squeegee from the road surface at desired points, and for towing the rubber blade or rubber squeegee in elevated position when moving between shots.
- 3.5. **Power Broom.** Furnish a rotary, self-propelled broom for initial sweeping and final surface sweeping.

- 3.6. **Emulsion Storage and Handling Equipment.** When the plans or the Engineer allows storage tanks, furnish a thermometer in each tank to indicate the emulsion temperature continuously. Keep equipment clean and free of leaks. Keep emulsion free of contamination.
- 3.7. **Aggregate Haul Trucks.** Unless otherwise authorized, use trucks of uniform capacity to deliver the aggregate. Provide documentation showing measurements and calculation in cubic yards. Clearly mark the calibrated level. Truck size may be limited when shown on the plans.
- 3.8. **Digital Measuring Instrument.** Furnish a vehicle with a calibrated digital-measuring instrument accurate to  $\pm 6$  ft. per mile.

## 4. CONSTRUCTION

- 4.1. **General.** Application season will be as shown on the plans. Emulsion and aggregate rates shown on the plans are for estimating purposes only. The Engineer will adjust the rates for the existing conditions.
- 4.2. **Temporary Aggregate Stockpiles.** The Engineer will approve the location of temporary aggregate stockpiles on the right of way before delivery. Place stockpiles in a manner that will not:
  - obstruct traffic or sight distance,
  - interfere with the access from abutting property, or
  - interfere with roadway drainage.

Locate stockpiles a minimum of 30 ft. from roadway when possible. Sign and barricade as shown on the plans.
- 4.3. **Aggregate Furnished by the Department.** When shown on the plans, the Department will furnish aggregate to the Contractor without cost. Stockpile locations are shown on the plans.
- 4.4. **Adverse Weather Conditions.** Do not place surface treatments when, in the Engineer's opinion, general weather conditions are unsuitable. Meet the requirements for air and surface temperature shown below.
- 4.4.1. **Standard Temperature Limitations.** Apply scrub seal when air temperature is above 40°F and rising.
- 4.4.2. **Cool Weather Night Air Temperature.** The Engineer reserves the right to review the National Oceanic and Atmospheric Administration (NOAA) weather forecast and determine if the nightly air temperature is suitable for placement to prevent aggregate loss.
- 4.4.3. **Cold Weather Application.** When application is allowed outside of the above temperature restrictions, the Engineer will approve the emulsion grade and the air and surface temperatures for application. Apply scrub seal at air and surface temperatures as directed.
- 4.5. **Surface Preparation.** Remove existing raised pavement markers. Repair any damage incurred by removal as directed. Remove dirt, dust, or other harmful material before sealing. Cracks in the pavement must be cleaned of debris using air blast cleaning. When shown on the plans, remove vegetation and blade pavement edges.
- 4.6. **Rock Land and Shot.**
- 4.6.1. **Definitions.**
  - A "rock land" is the area covered at the aggregate rate directed with 1 truckload of aggregate.
  - A "shot" is the area covered by 1 distributor load of emulsion.

4.6.2 **Setting Lengths.** Calculate the lengths of both rock land and shot. Adjust shot length to be an even multiple of the rock land. Verify that the distributor has enough emulsion to complete the entire shot length. Mark shot length before applying emulsion. When directed, mark length of each rock land to verify the aggregate rate.

4.7. **Emulsion Placement.**

4.7.1. **General.** Adjust the shot width so operations do not encroach on traffic or interfere with the traffic control plan, as directed. Use paper or other approved material at the beginning and end of each shot to construct a straight transverse joint and to prevent overlapping of the emulsion. Unless otherwise approved, match longitudinal joints with the lane lines. The Engineer may require a string line if necessary to keep joints straight with no overlapping. Use sufficient pressure to flare the nozzles fully. Select an application temperature, as approved, in accordance with Item 300. Uniformly apply the emulsion at the rate directed, within 15°F of the approved temperature, and not above the maximum allowable temperature.

4.7.2. **Squeegee.** Mechanically squeegee the freshly applied emulsion by using the rubber blade or rubber squeegee, so that the emulsion is evenly spread over the road surface and fills existing surface cracks.

4.7.3. **Limitations.** Do not apply emulsion to the roadway until:

- traffic control methods and devices are in place as shown on the plans or as directed,
- the loaded aggregate spreader is in position and ready to begin,
- haul trucks are loaded with enough aggregate to cover the shot area, and
- haul trucks are in place behind the spreader box.

4.7.4. **Non-uniform Application.** Stop application if it is not uniform due to streaking, ridging, puddling, flowing off the roadway surface, or not filling the cracks. Verify equipment condition, operating procedures, application temperature, and material properties. Determine and correct the cause of non-uniform application. If the cause is high or low emulsion viscosity, replace emulsion with material that corrects the problem.

4.7.5. **Test Strips.** The Engineer may stop application and require construction of test strips at the Contractor's expense if any of the following occurs:

- non-uniformity of application continues after corrective action;
- on 3 consecutive shots, application rate differs by more than 0.03 gal. per square yard from the rate directed; or
- any shot differs by more than 0.05 gal. per square yard from the rate directed.

The Engineer will approve the test strip location. The Engineer may require additional test strips until surface treatment application meets specification requirements.

4.8. **Aggregate Placement.** As soon as possible, apply aggregate uniformly at the rate directed without causing the rock to roll over.

4.9. **Rolling.** Start rolling operation on each shot as soon as aggregate applied. Use sufficient rollers to cover the entire mat width in 1 pass, i.e., 1 direction. Roll in a staggered pattern. Unless otherwise shown on the plans, make a minimum of 3 passes. If rollers are unable to keep up with the spreader box, stop application until rollers have caught up, or furnish additional rollers. Keep roller tires asphalt-free.

4.10. **Patching.** Before rolling, repair spots where coverage is incomplete. Repair can be made by hand spotting or other approved method. When necessary, apply additional emulsion to embed aggregate.

4.11. **Finishing Broom.** After rolling, sweep as soon as aggregate has sufficiently bonded to remove excess.

4.12. **Final Acceptance.** Maintain surface treatment until the Engineer accepts the work. Repair any surface failures. Before final project acceptance, remove all temporary stockpiles and restore the area to the original contour and grade.

---

**5. MEASUREMENT**

- 5.1. **Emulsion.** Unless otherwise shown on the plans, emulsion will be measured by one of the following methods:
- 5.1.1. **Volume.** Emulsion will be measured at the applied temperature by strapping the tank before and after road application and determining the net volume in gallons from the distributor's calibrated strap stick. The quantity to be measured for payment will be the number of gallons used, as directed, in the accepted surface treatment.
- 5.1.2. **Weight.** Emulsion will be measured in tons using certified scales meeting the requirements of Item 520, "Weighing and Measuring Equipment," unless otherwise approved. The transporting truck must have a seal attached to the draining device and other openings. The Engineer may require random checking on public scales at the Contractor's expense to verify weight accuracy. Upon work completion or temporary suspension, any remaining emulsion will be weighed by a certified public weigher, or measured by volume in a calibrated distributor or tank and the quantity converted to tons at the measured temperature. The quantity to be measured will be the number of tons received minus the number of tons remaining after all directed work is complete and minus the amount used for other items.
- 5.2. **Aggregate.** Aggregate will be measured by the cubic yard in the trucks as applied on the road. The Engineer may require loaded aggregate to be struck off for accurate measurement.
- 5.3. **Loading, Hauling, and Distributing Aggregate.** When the Department furnishes the aggregate, the loading, hauling, and distributing will be measured by the cubic yard in the trucks as applied on the road.

---

**6. PAYMENT**

The work performed and materials furnished in accordance with this Item and measured as provided under "Measurement" will be paid for at the unit prices bid for "Emulsion," "Aggregate," and "Loading, Hauling, and Distributing Aggregate" of the types-grades specified. These prices are full compensation for surface preparation; furnishing, preparing, hauling, and placing materials; removing existing pavement markers and excess aggregate; rolling; cleaning up stockpiles; and equipment, labor, tools, and incidentals.

**Exhibit A**

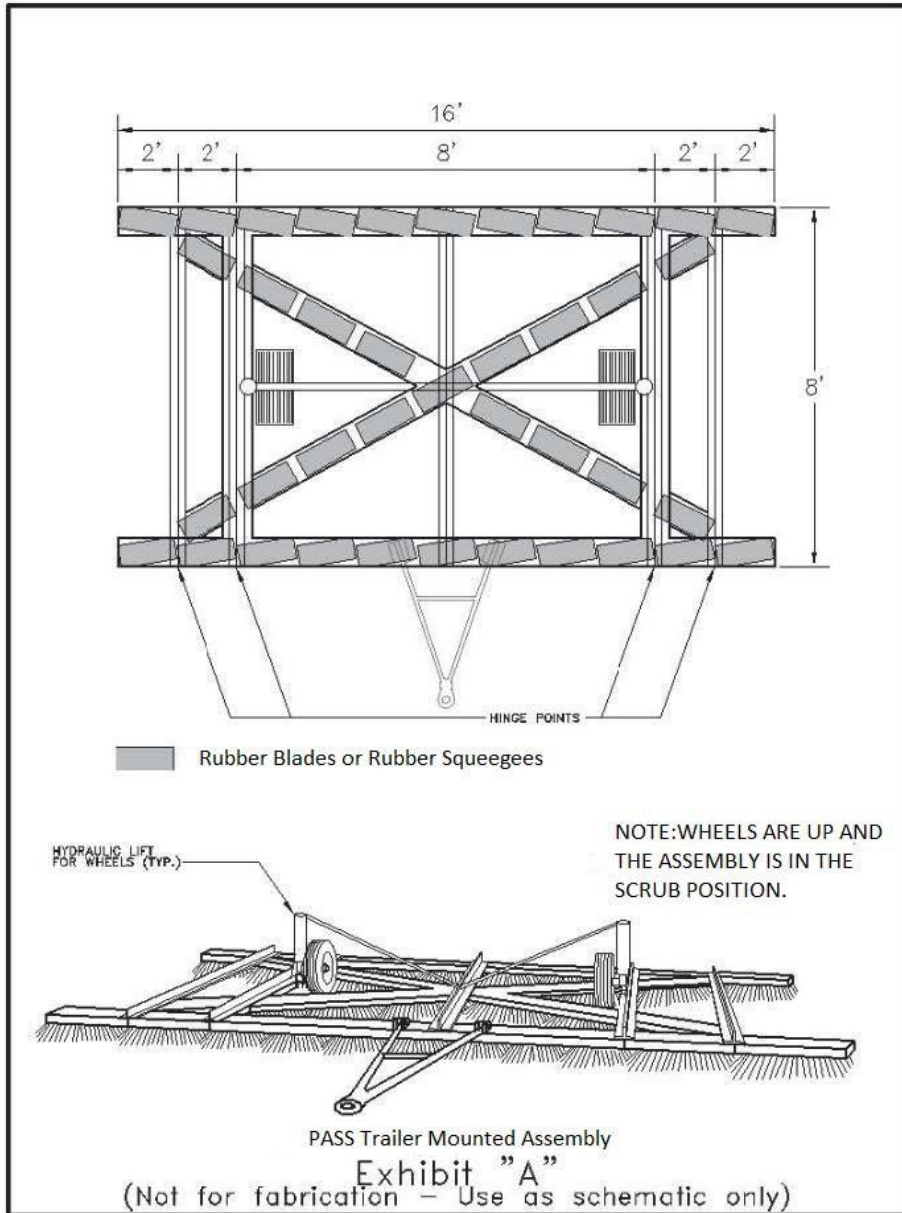

**Exhibit B**

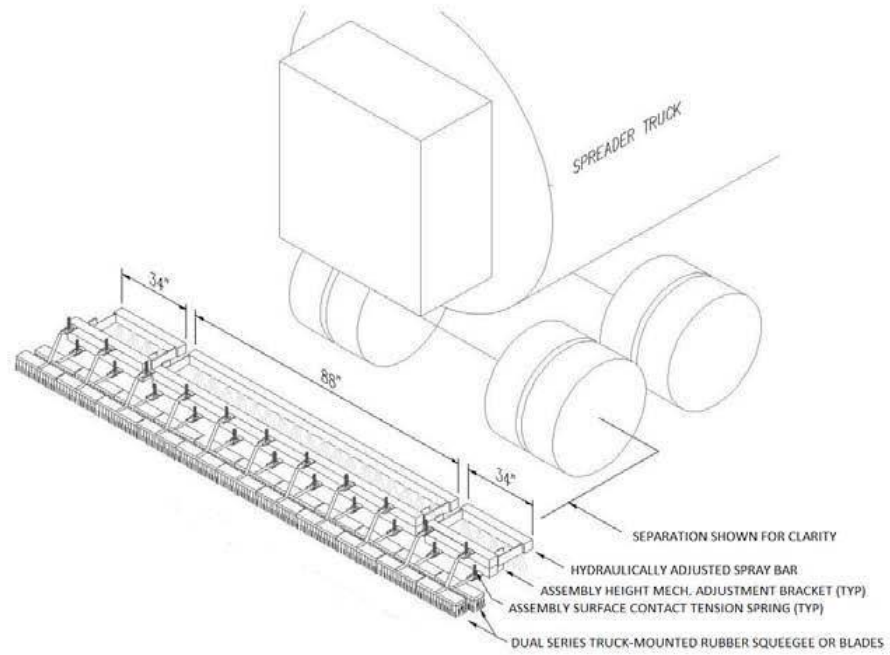

**TRUCK MOUNTED ASSEMBLY**

---