

DISCLAIMER: This standard is governed by the "Texas Engineering Practice Act". No warranty of any kind is made by TxDOT for any purpose whatsoever. TxDOT assumes no responsibility for the conversion of this standard to other formats or for incorrect results or damages resulting from its use.

STANDARD SBBS-B20-30	DESIGNED BEAMS (STRAIGHT STRANDS)																	OPTIONAL DESIGN							
	SPAN LENGTH (ft)	BEAM NO.	BEAM TYPE	PRESTRESSING STRANDS							DEBONDED STRAND PATTERN PER ROW							CONCRETE		DESIGN LOAD COMP STRESS (TOP ϵ) (SERVICE I)	DESIGN LOAD TENSILE STRESS (BOTT ϵ) (SERVICE III)	REQUIRED MINIMUM ULTIMATE MOMENT CAPACITY (STRENGTH I)	LIVE LOAD DISTRIBUTION FACTOR		
				NON- STD STRAND PATTERN	TOTAL NO.	SIZE (in)	STRGTH f_{pu} (ksi)	"e" \bar{c} (in)	"e" END (in)	TOT NO. DEB	DIST FROM BOTTOM (in)	NO. OF STRANDS		NUMBER OF STRANDS DEBONDED TO (ft from end)					RELEASE STRGTH f'_{ci} (ksi)				MINIMUM 28 DAY COMP STRGTH f'_c (ksi)	②	
												TOTAL	DE- BONDED	3	6	9	12	15						Moment	Shear
30' Roadway 5" Slab	30	1267	5B20		8	0.6	270	7.38	7.38	0	2.50	8	0	0	0	0	0	4.000	5.000	0.648	-0.817	701	0.440	0.691	
	30	3-5	4B20		6	0.6	270	7.31	7.31	0	2.50	6	0	0	0	0	0	4.000	5.000	0.686	-0.848	588	0.357	0.511	
	35	1267	5B20		8	0.6	270	7.38	7.38	0	2.50	8	0	0	0	0	0	4.000	5.000	0.853	-1.055	796	0.426	0.680	
	35	3-5	4B20		6	0.6	270	7.31	7.31	0	2.50	6	0	0	0	0	0	4.000	5.000	0.902	-1.096	615	0.355	0.498	
	40	1267	5B20		10	0.6	270	7.38	7.38	0	2.50	10	0	0	0	0	0	4.000	5.000	1.084	-1.319	890	0.414	0.671	
	40	3-5	4B20		8	0.6	270	7.31	7.31	0	2.50	8	0	0	0	0	0	4.000	5.000	1.148	-1.374	712	0.346	0.488	
	45	1267	5B20		10	0.6	270	7.38	7.38	0	2.50	10	0	0	0	0	0	4.000	5.000	1.346	-1.620	962	0.404	0.663	
	45	3-5	4B20		8	0.6	270	7.31	7.31	0	2.50	8	0	0	0	0	0	4.000	5.000	1.426	-1.688	809	0.337	0.481	
	50	1267	5B20		12	0.6	270	7.38	7.38	0	2.50	12	0	0	0	0	0	4.000	5.000	1.647	-1.968	1153	0.396	0.655	
	50	3-5	4B20		10	0.6	270	7.31	7.31	0	2.50	10	0	0	0	0	0	4.000	5.400	1.744	-2.050	969	0.330	0.476	
	55	1267	5B20		16	0.6	270	7.38	7.38	0	2.50	16	0	0	0	0	0	4.000	5.000	1.973	-2.341	1352	0.388	0.649	
	55	3-5	4B20		14	0.6	270	7.31	7.31	0	2.50	14	0	0	0	0	0	4.000	5.000	2.091	-2.441	1138	0.324	0.471	
	60	1267	5B20		20	0.6	270	7.38	7.38	2	2.50	20	2	2	0	0	0	4.000	5.000	2.325	-2.741	1561	0.381	0.643	
	60	3-5	4B20		16	0.6	270	7.31	7.31	2	2.50	16	2	2	0	0	0	4.000	5.500	2.464	-2.859	1315	0.318	0.467	
65	1267	5B20		24	0.6	270	7.38	7.38	6	2.50	24	6	2	2	0	2	4.000	5.000	2.705	-3.168	1782	0.375	0.638		
65	3-5	4B20		20	0.6	270	7.31	7.31	4	2.50	20	4	0	2	0	2	4.000	5.000	2.867	-3.306	1501	0.313	0.463		

DESIGN NOTES:
 Designed in accordance with AASHTO LRFD Bridge Design Specifications.
 Prestress losses for the designed beams have been calculated for a relative humidity of 60 percent. Optional designs must likewise conform.
 Beam designs are applicable for 5" concrete slabs without overlay and 0 degree skew.

FABRICATION NOTES:
 Provide Class H concrete.
 Provide Grade 60 reinforcing steel bars.
 Use low relaxation strands, each pretensioned to 75 percent of f_{pu} .
 When shown on this sheet, the Fabricator has the option of furnishing either the designed beam or an approved optional beam design. All optional design submittals and shop drawings must be signed, sealed and dated by a Professional Engineer registered in the State of Texas.
 Locate strands for the designed beam as low as possible on the 2" grid system unless a non-standard stand pattern is indicated. Fill row "2.5", then row "4.5", then row "6.5", etc. Place strands within a row as follows:
 1) Locate a strand in each "1" position.
 2) Place strand symmetrically about vertical centerline of box.
 3) Space strands as equally as possible across the entire width.
 Strand debonding must comply with Item 424.4.2.2.4.
 Do not debond strands in position "1". Distribute debonded strands equally about the vertical centerline. Decrease debonded lengths working inward, with debonding staggered in each row.
 Full-length debonded strands are only permitted in positions marked Δ .

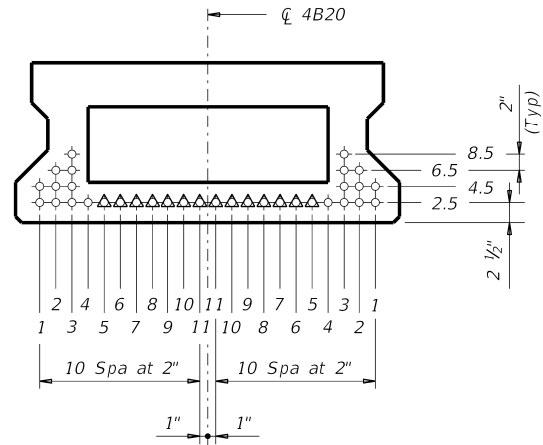

TxDOT 4B20 BOX BEAM

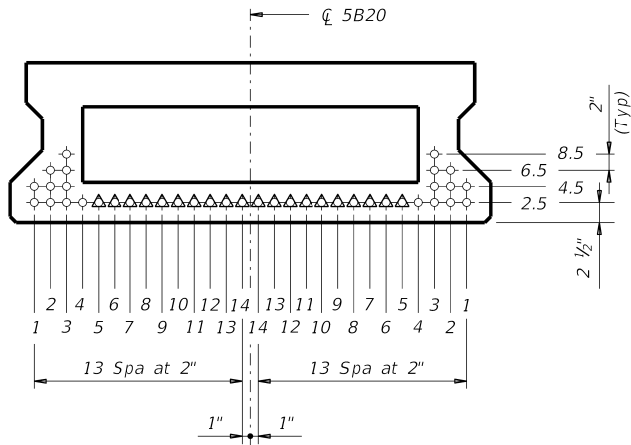

TxDOT 5B20 BOX BEAM

- ① Based on the following allowable stresses (ksi):
 Compression = $0.65 f'_{ci}$
 Tension = $0.24 \sqrt{f'_{ci}}$
 Optional designs must likewise conform.
- ② Portion of full HL93.

HL93 LOADING



**PRESTR CONC BOX BEAM
 STANDARD DESIGNS
 TYPE B20 30' RDWY
 (WITH SLAB)**

BBSDS-B20-30

FILE: BB-SOSB2030-16.dgn	DN: SRW	CK: BMP	DW: SFS	CK: SDB
©TxDOT December 2006	CONT	SECT	JOB	HIGHWAY
REVISIONS				
04-11: f'_{ci} and LLDF.	DIST	COUNTY	SHEET NO.	
01-16: Notes, 0.6" strand designs.				

DATE:
FILE: