

DISCLAIMER: This standard is governed by the "Texas Engineering Practice Act". No warranty of any kind is made by TxDOT for any purpose whatsoever. TxDOT assumes no responsibility for the conversion to other formats or for incorrect results or damages resulting from its use.

STANDARD SBBS-B28-24	DESIGNED BEAMS (STRAIGHT STRANDS)																	OPTIONAL DESIGN							
	SPAN LENGTH (ft)	BEAM NO.	BEAM TYPE	PRESTRESSING STRANDS						DEBONDED STRAND PATTERN PER ROW					CONCRETE		DESIGN LOAD COMP STRESS (TOP ϵ) (SERVICE I) fct(ksi)	DESIGN LOAD TENSILE STRESS (BOTT ϵ) (SERVICE III) fcb(ksi)	REQUIRED MINIMUM ULTIMATE MOMENT CAPACITY (STRENGTH I) (ft-kips)	LIVE LOAD DISTRIBUTION FACTOR					
				NON-STD STRAND PATTERN	TOTAL NO.	SIZE (in)	STRGTH (ksi)	"e" \bar{c} (in)	"e" END (in)	TOT NO. DEB	DIST FROM BOTTOM (in)	NO. OF STRANDS		NUMBER OF STRANDS DEBONDED TO (ft from end)						RELEASE STRGTH f'_{ci} (ksi)	MINIMUM 28 DAY COMP STRGTH f'_c (ksi)	②			
												TOTAL	DE-BONDED	3	6	9						12	15	Moment	Shear
24' Roadway 5" Slab	30	1&6	5B28		8	0.6	270	11.24	11.24	0	2.50	8	0	0	0	0	0	0	4.000	5.000	0.438	-0.522	736	0.461	0.699
	30	2-5	4B28		6	0.6	270	11.12	11.12	0	2.50	6	0	0	0	0	0	0	4.000	5.000	0.489	-0.566	640	0.384	0.517
	35	1&6	5B28		8	0.6	270	11.24	11.24	0	2.50	8	0	0	0	0	0	0	4.000	5.000	0.571	-0.672	920	0.446	0.688
	35	2-5	4B28		8	0.6	270	11.12	11.12	0	2.50	8	0	0	0	0	0	0	4.000	5.000	0.642	-0.733	804	0.372	0.505
	40	1&6	5B28		10	0.6	270	11.24	11.24	0	2.50	10	0	0	0	0	0	0	4.000	5.000	0.722	-0.839	1120	0.434	0.679
	40	2-5	4B28		8	0.6	270	11.12	11.12	0	2.50	8	0	0	0	0	0	0	4.000	5.000	0.815	-0.919	982	0.362	0.494
	45	1&6	5B28		10	0.6	270	11.24	11.24	0	2.50	10	0	0	0	0	0	0	4.000	5.000	0.893	-1.028	1343	0.423	0.670
	45	2-5	4B28		8	0.6	270	11.12	11.12	0	2.50	8	0	0	0	0	0	0	4.000	5.000	1.010	-1.130	1077	0.353	0.487
	50	1&6	5B28		10	0.6	270	11.24	11.24	0	2.50	10	0	0	0	0	0	0	4.000	5.000	1.088	-1.246	1330	0.414	0.663
	50	2-5	4B28		8	0.6	270	11.12	11.12	0	2.50	8	0	0	0	0	0	0	4.000	5.000	1.235	-1.373	1068	0.346	0.482
	55	1&6	5B28		12	0.6	270	11.24	11.24	0	2.50	12	0	0	0	0	0	0	4.000	5.000	1.301	-1.480	1467	0.406	0.657
	55	2-5	4B28		10	0.6	270	11.12	11.12	0	2.50	10	0	0	0	0	0	0	4.000	5.000	1.478	-1.635	1255	0.339	0.477
	60	1&6	5B28		12	0.6	270	11.24	11.24	0	2.50	12	0	0	0	0	0	0	4.000	5.000	1.529	-1.731	1642	0.399	0.651
	60	2-5	4B28		12	0.6	270	11.12	11.12	0	2.50	12	0	0	0	0	0	0	4.000	5.000	1.741	-1.916	1453	0.333	0.473
	65	1&6	5B28		14	0.6	270	11.24	11.24	0	2.50	14	0	0	0	0	0	0	4.000	5.000	1.775	-1.999	1875	0.393	0.645
	65	2-5	4B28		14	0.6	270	11.12	11.12	0	2.50	14	0	0	0	0	0	0	4.000	5.000	2.031	-2.227	1676	0.333	0.469
	70	1&6	5B28		18	0.6	270	11.24	11.24	0	2.50	18	0	0	0	0	0	0	4.000	5.000	2.036	-2.283	2118	0.387	0.641
	70	2-5	4B28		16	0.6	270	11.12	11.12	0	2.50	16	0	0	0	0	0	0	4.000	5.000	2.341	-2.560	1911	0.333	0.465
75	1&6	5B28		20	0.6	270	11.24	11.24	0	2.50	20	0	0	0	0	0	0	4.000	5.000	2.314	-2.583	2372	0.381	0.636	
75	2-5	4B28		20	0.6	270	11.12	11.12	2	2.50	20	2	0	2	0	0	0	4.000	5.000	2.673	-2.913	2158	0.333	0.462	

DESIGN NOTES:
 Designed in accordance with AASHTO LRFD Bridge Design Specifications.
 Prestress losses for the designed beams have been calculated for a relative humidity of 60 percent. Optional designs must likewise conform.
 Beam designs are applicable for 5" concrete slabs without overlay and 0 degree skew.

FABRICATION NOTES:
 Provide Class H concrete.
 Provide Grade 60 reinforcing steel bars.
 Use low relaxation strands, each pretensioned to 75 percent of fpu.
 When shown on this sheet, the Fabricator has the option of furnishing either the designed beam or an approved optional beam design. All optional design submittals and shop drawings must be signed, sealed and dated by a Professional Engineer registered in the State of Texas.
 Locate strands for the designed beam as low as possible on the 2" grid system unless a non-standard stand pattern is indicated. Fill row "2.5", then row "4.5", then row "6.5", etc. Place strands within a row as follows:
 1) Locate a strand in each "1" position.
 2) Place strand symmetrically about vertical centerline of box.
 3) Space strands as equally as possible across the entire width.
 Strand debonding must comply with Item 424.4.2.2.4.
 Do not debond strands in position "1". Distribute debonded strands equally about the vertical centerline. Decrease debonded lengths working inward, with debonding staggered in each row.
 Full-length debonded strands are only permitted in positions marked Δ .

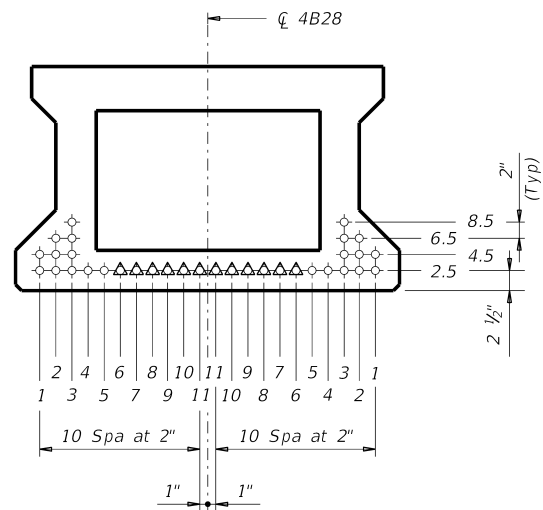

TxDOT 4B28 BOX BEAM

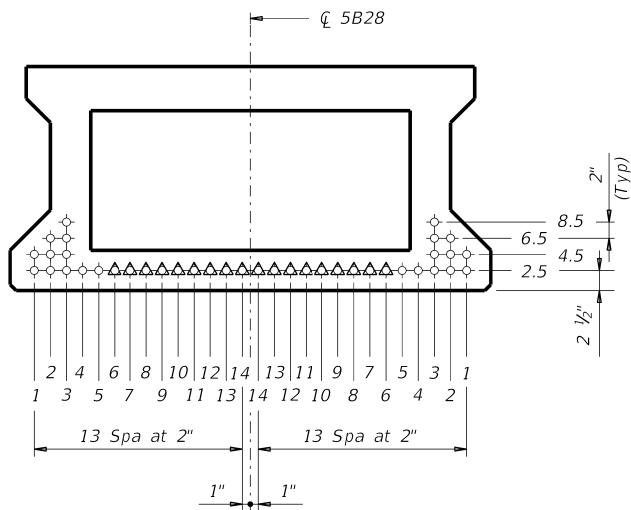

TxDOT 5B28 BOX BEAM

- ① Based on the following allowable stresses (ksi):
 Compression = $0.65 f'_{ci}$
 Tension = $0.24 \sqrt{f'_{ci}}$
 Optional designs must likewise conform.
- ② Portion of full HL93.

HL93 LOADING



**PRESTR CONC BOX BEAM
 STANDARD DESIGNS
 TYPE B28 24' RDWY
 (WITH SLAB)**

BBSDS-B28-24

FILE: BB-SDSB2824-16.dgn	DN: SRW	CK: BMP	DW: SFS	CK: SDB
©TxDOT December 2006	CONT	SECT	JOB	HIGHWAY
REVISIONS				
04-11: f'ci and LLDf.	DIST	COUNTY	SHEET NO.	
01-16: Notes, 0.6" strand designs.				

DATE:
FILE: