

DISCLAIMER: This standard is governed by the "Texas Engineering Practice Act". No warranty of any kind is made by TxDOT for any purpose whatsoever. TxDOT assumes no responsibility for the conversion of this standard to other formats or for incorrect results or damages resulting from its use.

DATE: FILE:

STANDARD SBBS-B28-30	DESIGNED BEAMS (STRAIGHT STRANDS)																	OPTIONAL DESIGN							
	SPAN LENGTH (ft)	BEAM NO.	BEAM TYPE	PRESTRESSING STRANDS							DEBONDED STRAND PATTERN PER ROW					CONCRETE		DESIGN LOAD COMP STRESS (TOP ϵ) (SERVICE I)	DESIGN LOAD TENSILE STRESS (BOTTOM ϵ) (SERVICE III)	REQUIRED MINIMUM ULTIMATE MOMENT CAPACITY (STRENGTH I)	LIVE LOAD DISTRIBUTION FACTOR				
				NON-STD STRAND PATTERN	TOTAL NO.	SIZE (in)	STRGTH (ksi)	"e" \bar{c} (in)	"e" END (in)	TOT NO. DEB	DIST FROM BOTTOM (in)	NO. OF STRANDS		NUMBER OF STRANDS DEBONDED TO (ft from end)							RELEASE STRGTH (1) f'_{ci} (ksi)	MINIMUM 28 DAY COMP STRGTH f'_c (ksi)	LIVE LOAD DISTRIBUTION FACTOR (2)		
												TOTAL	DE-BONDED	3	6	9	12						15	Moment	Shear
30' Roadway 5" Slab	30	1267	5B28		8	0.6	270	11.24	11.24	0	2.50	8	0	0	0	0	0	0	4.000	5.000	0.452	-0.537	742	0.447	0.699
	30	3-5	4B28		6	0.6	270	11.12	11.12	0	2.50	6	0	0	0	0	0	0	4.000	5.000	0.484	-0.559	628	0.373	0.517
	35	1267	5B28		8	0.6	270	11.24	11.24	0	2.50	8	0	0	0	0	0	0	4.000	5.000	0.594	-0.695	932	0.433	0.688
	35	3-5	4B28		8	0.6	270	11.12	11.12	0	2.50	8	0	0	0	0	0	0	4.000	5.000	0.637	-0.725	790	0.361	0.505
	40	1267	5B28		10	0.6	270	11.24	11.24	0	2.50	10	0	0	0	0	0	0	4.000	5.000	0.753	-0.871	1137	0.421	0.679
	40	3-5	4B28		8	0.6	270	11.12	11.12	0	2.50	8	0	0	0	0	0	0	4.000	5.000	0.808	-0.909	966	0.351	0.494
	45	1267	5B28		10	0.6	270	11.24	11.24	0	2.50	10	0	0	0	0	0	0	4.000	5.000	0.935	-1.070	1342	0.411	0.670
	45	3-5	4B28		8	0.6	270	11.12	11.12	0	2.50	8	0	0	0	0	0	0	4.000	5.000	1.003	-1.119	1077	0.342	0.487
	50	1267	5B28		12	0.6	270	11.24	11.24	0	2.50	12	0	0	0	0	0	0	4.000	5.000	1.142	-1.300	1477	0.402	0.663
	50	3-5	4B28		8	0.6	270	11.12	11.12	0	2.50	8	0	0	0	0	0	0	4.000	5.000	1.227	-1.360	1063	0.335	0.482
	55	1267	5B28		12	0.6	270	11.24	11.24	0	2.50	12	0	0	0	0	0	0	4.000	5.000	1.367	-1.547	1463	0.394	0.657
	55	3-5	4B28		10	0.6	270	11.12	11.12	0	2.50	10	0	0	0	0	0	0	4.000	5.000	1.470	-1.621	1237	0.329	0.477
	60	1267	5B28		12	0.6	270	11.24	11.24	0	2.50	12	0	0	0	0	0	0	4.000	5.000	1.610	-1.812	1681	0.387	0.651
	60	3-5	4B28		12	0.6	270	11.12	11.12	0	2.50	12	0	0	0	0	0	0	4.000	5.000	1.731	-1.900	1433	0.323	0.473
	65	1267	5B28		16	0.6	270	11.24	11.24	0	2.50	16	0	0	0	0	0	0	4.000	5.000	1.872	-2.096	1923	0.381	0.645
	65	3-5	4B28		14	0.6	270	11.12	11.12	0	2.50	14	0	0	0	0	0	0	4.000	5.000	2.012	-2.197	1637	0.317	0.469
	70	1267	5B28		18	0.6	270	11.24	11.24	0	2.50	18	0	0	0	0	0	0	4.000	5.000	2.151	-2.397	2176	0.375	0.641
	70	3-5	4B28		16	0.6	270	11.12	11.12	0	2.50	16	0	0	0	0	0	0	4.000	5.000	2.314	-2.517	1856	0.313	0.465
75	1267	5B28		22	0.6	270	11.24	11.24	2	2.50	22	2	2	0	0	0	0	4.000	5.000	2.448	-2.717	2442	0.370	0.636	
75	3-5	4B28		20	0.6	270	11.12	11.12	2	2.50	20	2	0	2	0	0	0	4.000	5.000	2.633	-2.853	2082	0.308	0.462	

DESIGN NOTES:
 Designed in accordance with AASHTO LRFD Bridge Design Specifications.
 Prestress losses for the designed beams have been calculated for a relative humidity of 60 percent. Optional designs must likewise conform.
 Beam designs are applicable for 5" concrete slabs without overlay and 0 degree skew.

FABRICATION NOTES:
 Provide Class H concrete.
 Provide Grade 60 reinforcing steel bars.
 Use low relaxation strands, each pretensioned to 75 percent of f_{pu} .
 When shown on this sheet, the Fabricator has the option of furnishing either the designed beam or an approved optional beam design. All optional design submittals and shop drawings must be signed, sealed and dated by a Professional Engineer registered in the State of Texas.
 Locate strands for the designed beam as low as possible on the 2" grid system unless a non-standard stand pattern is indicated. Fill row "2.5", then row "4.5", then row "6.5", etc. Place strands within a row as follows:
 1) Locate a strand in each "1" position.
 2) Place strand symmetrically about vertical centerline of box.
 3) Space strands as equally as possible across the entire width.
 Strand debonding must comply with Item 424.4.2.2.4.
 Do not debond strands in position "1". Distribute debonded strands equally about the vertical centerline. Decrease debonded lengths working inward, with debonding staggered in each row.
 Full-length debonded strands are only permitted in positions marked Δ .

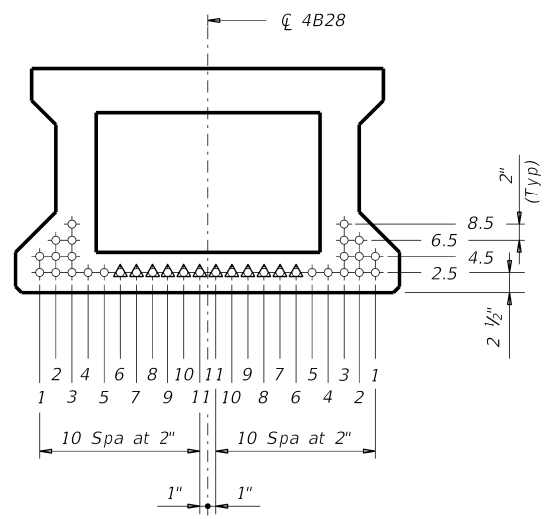

TxDOT 4B28 BOX BEAM

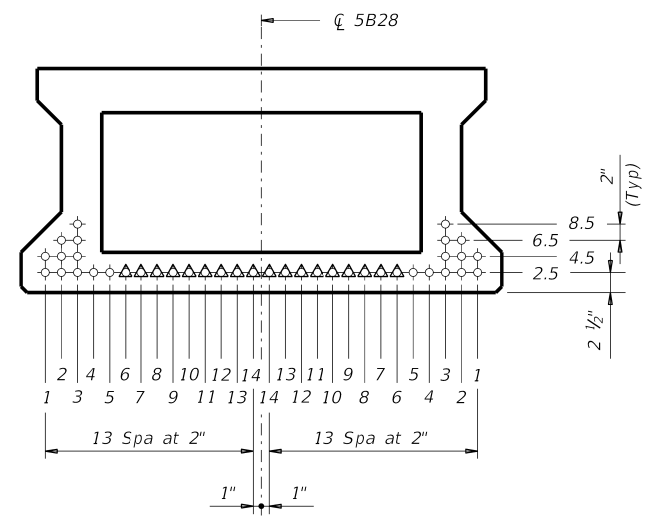

TxDOT 5B28 BOX BEAM

- ① Based on the following allowable stresses (ksi):
 Compression = $0.65 f'_{ci}$
 Tension = $0.24 \sqrt{f'_{ci}}$
 Optional designs must likewise conform.
- ② Portion of full HL93.

HL93 LOADING

		Bridge Division Standard	
PRESTR CONC BOX BEAM STANDARD DESIGNS			
TYPE B28		30' RDWY (WITH SLAB)	
BBSDBS-B28-30			
FILE: BB-SDB2830-16.dgn	DN: SRW	CK: BMP	DW: SFS
©TxDOT December 2006	CONT	SECT	JOB
REVISIONS			
04-11: f'ci and LLDF.	DIST	COUNTY	SHEET NO.
01-16: Notes, 0.6" strand designs.			