

DISCLAIMER: The use of this standard is governed by the "Texas Engineering Practice Act." No warranty of any kind is made by TxDOT for any purpose whatsoever. TxDOT assumes no responsibility for the conversion of this standard to other formats or for incorrect results or damages resulting from its use.

**TABLE OF VARIABLE DIMENSIONS AND QUANTITIES FOR ONE HEADWALL (5)**

Slope	Dia of Pipe (D)	Values for One Pipe					Values to be Added for Each Add'l Pipe			
		W	X	Y	L	Reinf (Lbs)	Conc (CY)	X and W	Reinf (Lbs)	Conc (CY)
2:1	12"	4'-7 1/2"	2'-6"	2'-10"	3'-3 1/4"	88	0.6	1'-9"	20	0.2
	15"	5'-5 3/4"	2'-9 1/2"	3'-4"	3'-10 1/4"	103	0.7	2'-2"	24	0.3
	18"	6'-4 1/4"	3'-1"	3'-10"	4'-5"	124	0.9	2'-8"	32	0.3
	21"	7'-2 3/4"	3'-4 1/2"	4'-4"	5'-0"	143	1.1	3'-1"	43	0.4
	24"	8'-2 1/2"	3'-9 1/2"	4'-10"	5'-7"	164	1.3	3'-7"	50	0.5
	27"	9'-1"	4'-1"	5'-4"	6'-2"	179	1.5	3'-11"	56	0.6
	30"	9'-11 1/2"	4'-4 1/2"	5'-10"	6'-8 3/4"	203	1.7	4'-4"	65	0.8
	33"	10'-10"	4'-8"	6'-4"	7'-3 3/4"	224	2.0	4'-8"	71	0.9
	36"	11'-8 1/4"	4'-11 1/2"	6'-10"	7'-10 3/4"	249	2.2	5'-1"	81	1.0
	42"	13'-5 1/4"	5'-6 1/2"	7'-10"	9'-0 1/2"	298	2.8	5'-10"	97	1.3
	48"	15'-9"	6'-1 1/2"	9'-4"	10'-9 1/4"	360	3.8	6'-7"	117	1.7
	54"	17'-5 3/4"	6'-8 1/2"	10'-4"	11'-11 1/4"	427	4.5	7'-6"	151	2.1
60"	19'-2 3/4"	7'-3 3/4"	11'-4"	13'-1"	481	5.3	8'-3"	174	2.5	
66"	20'-11 1/2"	7'-10 1/2"	12'-4"	14'-3"	544	6.2	8'-9"	194	2.9	
72"	22'-8 1/2"	8'-5 1/2"	13'-4"	15'-4 3/4"	601	7.1	9'-4"	213	3.3	
3:1	12"	6'-3"	2'-6"	4'-3"	4'-11"	118	0.8	1'-9"	22	0.2
	15"	7'-5"	2'-9 1/2"	5'-0"	5'-9 1/4"	137	1.1	2'-2"	28	0.3
	18"	8'-6 3/4"	3'-1"	5'-9"	6'-7 3/4"	170	1.3	2'-8"	37	0.5
	21"	9'-8 3/4"	3'-4 1/2"	6'-6"	7'-6"	195	1.6	3'-1"	48	0.6
	24"	11'-0"	3'-9 1/2"	7'-3"	8'-4 1/2"	227	2.0	3'-7"	58	0.7
	27"	12'-2"	4'-1"	8'-0"	9'-2 3/4"	251	2.3	3'-11"	67	0.8
	30"	13'-4"	4'-4 1/2"	8'-9"	10'-1 1/4"	293	2.7	4'-4"	77	1.0
	33"	14'-5 3/4"	4'-8"	9'-6"	10'-11 3/4"	318	3.1	4'-8"	84	1.2
	36"	15'-7 3/4"	4'-11 1/2"	10'-3"	11'-10"	351	3.5	5'-1"	96	1.4
	42"	17'-11 1/2"	5'-6 1/2"	11'-9"	13'-6 3/4"	432	4.5	5'-10"	119	1.7
	48"	21'-1 3/4"	6'-1 1/2"	14'-0"	16'-2"	537	6.1	6'-7"	146	2.3
	54"	23'-5 1/2"	6'-8 1/2"	15'-6"	17'-10 3/4"	630	7.3	7'-6"	186	2.9
60"	25'-9 1/4"	7'-3 1/2"	17'-0"	19'-7 1/2"	719	8.7	8'-3"	219	3.4	
66"	28'-1"	7'-10 1/2"	18'-6"	21'-4 1/4"	811	10.1	8'-9"	242	3.9	
72"	30'-4 3/4"	8'-5 1/2"	20'-0"	23'-1 1/4"	924	11.7	9'-4"	272	4.4	
4:1	12"	7'-10 3/4"	2'-6"	5'-8"	6'-6 1/2"	148	1.1	1'-9"	24	0.3
	15"	9'-4"	2'-9 1/2"	6'-8"	7'-8 1/2"	181	1.5	2'-2"	32	0.4
	18"	10'-9 1/2"	3'-1"	7'-8"	8'-10 1/4"	221	1.9	2'-8"	42	0.5
	21"	12'-2 3/4"	3'-4 1/2"	8'-8"	10'-0"	260	2.3	3'-1"	57	0.7
	24"	13'-9 1/2"	3'-9 1/2"	9'-8"	11'-2"	301	2.8	3'-7"	67	0.9
	27"	15'-3"	4'-1"	10'-8"	12'-3 3/4"	334	3.3	3'-11"	77	1.0
	30"	16'-8 1/4"	4'-4 1/2"	11'-8"	13'-5 3/4"	385	3.8	4'-4"	89	1.3
	33"	18'-1 3/4"	4'-8"	12'-8"	14'-7 1/2"	425	4.5	4'-8"	101	1.4
	36"	19'-7"	4'-11 1/2"	13'-8"	15'-9 1/4"	472	5.1	5'-1"	115	1.7
	42"	22'-5 3/4"	5'-6 1/2"	15'-8"	18'-1"	583	6.5	5'-10"	141	2.1
	48"	26'-6 1/4"	6'-1 1/2"	18'-8"	21'-6 3/4"	730	8.9	6'-7"	175	2.8
	54"	29'-5"	6'-8 1/2"	20'-8"	23'-10 1/4"	875	10.7	7'-6"	226	3.6
60"	32'-3 3/4"	7'-3 1/2"	22'-8"	26'-2"	996	12.7	8'-3"	264	4.3	
66"	35'-2 1/2"	7'-10 1/2"	24'-8"	28'-5 3/4"	1,140	14.9	8'-9"	300	4.9	
72"	38'-1 1/4"	8'-5 1/2"	26'-8"	30'-9 1/2"	1,297	17.3	9'-4"	334	5.6	
6:1	12"	11'-2"	2'-6"	8'-6"	9'-9 3/4"	224	1.9	1'-9"	28	0.4
	15"	13'-2 1/4"	2'-9 1/2"	10'-0"	11'-6 1/2"	268	2.5	2'-2"	37	0.5
	18"	15'-2 1/2"	3'-1"	11'-6"	13'-3 1/4"	330	3.2	2'-8"	50	0.7
	21"	17'-2 3/4"	3'-4 1/2"	13'-0"	15'-0 1/4"	387	3.9	3'-1"	69	0.9
	24"	19'-4 1/2"	3'-9 1/2"	14'-6"	16'-9"	453	4.8	3'-7"	80	1.2
	27"	21'-4 3/4"	4'-1"	16'-0"	18'-5 3/4"	512	5.7	3'-11"	96	1.4
	30"	23'-5 1/4"	4'-4 1/2"	17'-6"	20'-2 1/2"	593	6.7	4'-4"	110	1.7
	33"	25'-5 1/2"	4'-8"	19'-0"	21'-11 1/4"	675	7.8	4'-8"	127	2.0
	36"	27'-5 3/4"	4'-11 1/2"	20'-6"	23'-8"	735	9.0	5'-1"	144	2.3
	42"	31'-6 1/4"	5'-6 1/2"	23'-6"	27'-1 1/2"	922	11.5	5'-10"	179	3.0
	48"	37'-3 1/2"	6'-1 1/2"	28'-0"	32'-4"	1,191	15.9	6'-7"	231	4.0
	54"	41'-4 1/4"	6'-8 1/2"	31'-0"	35'-9 1/2"	1,424	19.2	7'-6"	300	5.0
60"	45'-4 3/4"	7'-3 1/2"	34'-0"	39'-3"	1,631	22.9	8'-3"	353	6.0	

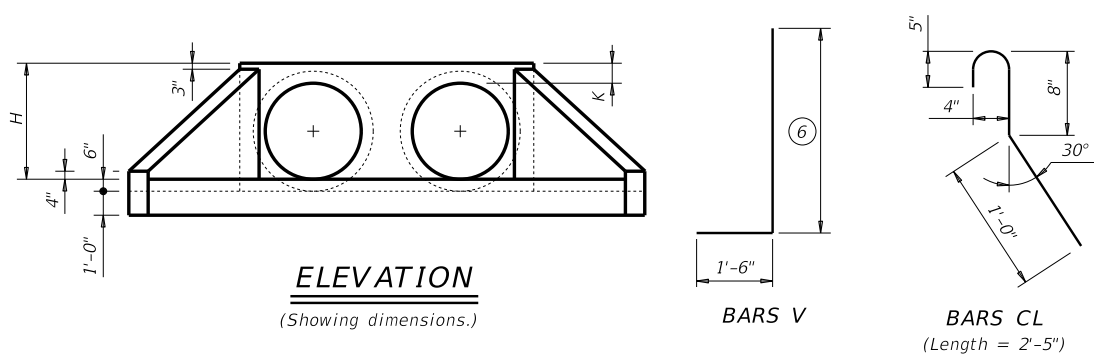
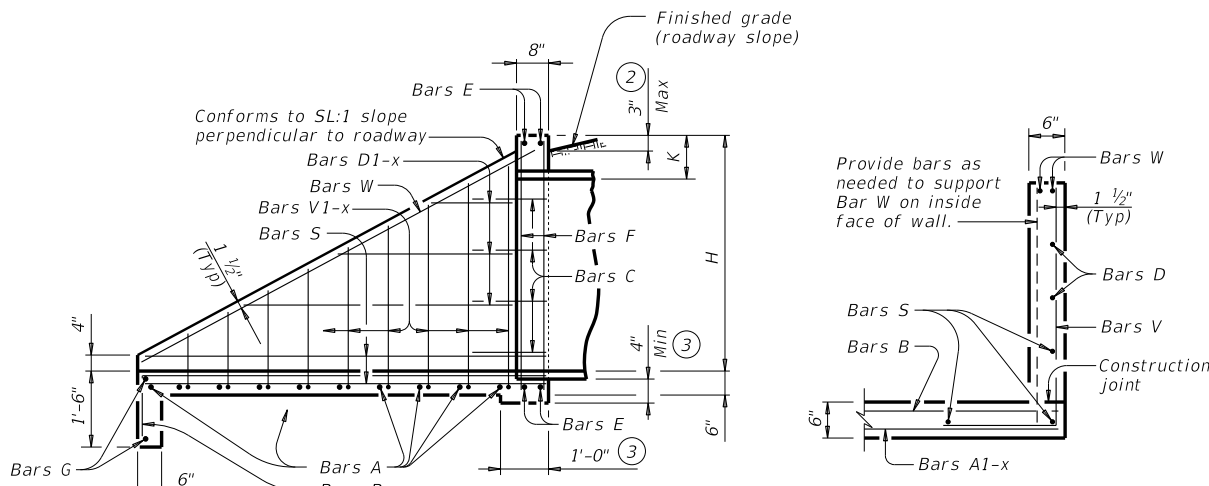
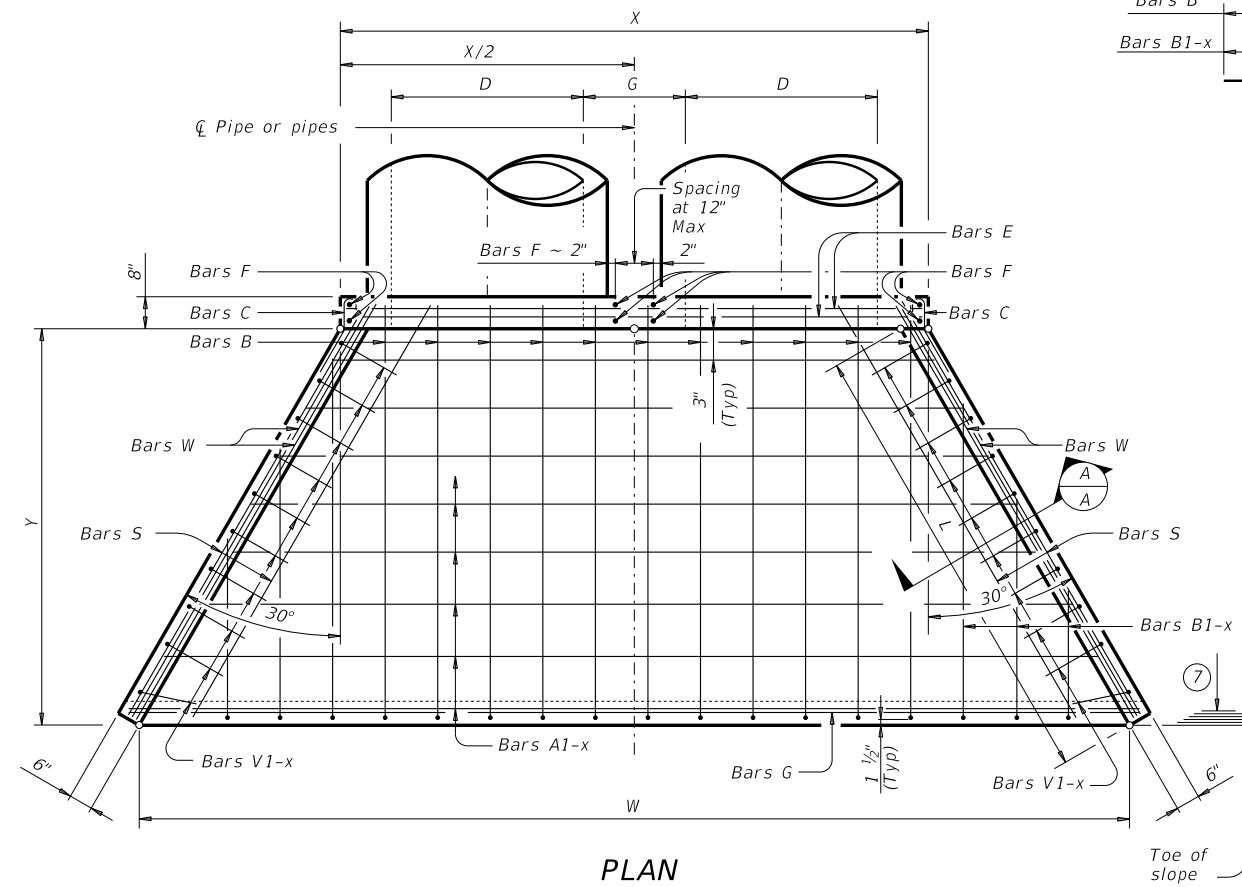
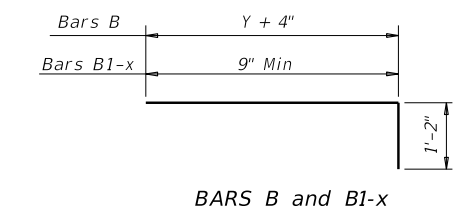

**TABLE OF REINFORCING STEEL**

Bar	Size	Spa	No.
A	#4	1' - 0"	~
B	#3	1' - 6"	~
C	#4	1' - 0"	~
D	#3	1' - 0"	~
E	#5	~	4
F	#5	~	~
G	#3	~	2
S	#4	~	6
V	#4	1' - 0"	~
W	#5	~	4

**TABLE OF CONSTANT DIMENSIONS**

Dia of Pipe (D)	G	K (4)	H
12"	0' - 9"	1' - 0"	2' - 0"
15"	0' - 11"	1' - 0"	2' - 3"
18"	1' - 2"	1' - 0"	2' - 6"
21"	1' - 4"	1' - 0"	2' - 9"
24"	1' - 7"	1' - 0"	3' - 0"
27"	1' - 8"	1' - 0"	3' - 3"
30"	1' - 10"	1' - 0"	3' - 6"
33"	1' - 11"	1' - 0"	3' - 9"
36"	2' - 1"	1' - 0"	4' - 0"
42"	2' - 4"	1' - 0"	4' - 6"
48"	2' - 7"	1' - 3"	5' - 3"
54"	3' - 0"	1' - 3"	5' - 9"
60"	3' - 3"	1' - 3"	6' - 3"
66"	3' - 3"	1' - 3"	6' - 9"
72"	3' - 4"	1' - 3"	7' - 3"



- Quantities shown are for concrete pipe and will increase slightly for metal pipe installations.
  - For vehicle safety, construct curbs no more than 3" above finished grade. Reduce curb heights, if necessary, to meet these requirements. No changes will be made in quantities and no additional compensation will be allowed for this work.
  - Provide a 1'-0" footing as shown where required to maintain 4" minimum cover for pipes.
  - Dimensions shown are usual and maximum.
  - Quantities shown are for one structure end only (one headwall).
  - Min Length =  $6" + 3" \times \left( \frac{12 \times H - 7}{12 \times L} \right)$   
Max Length =  $12 \times H - 3" \times \left( \frac{12 \times H - 7}{12 \times L} \right) - 1"$
  - Lengths of wings based on SL:1 slope along this line.
- MATERIAL NOTES:**  
Provide Grade 60 reinforcing steel.  
Provide Class C concrete (f'c = 3,600 psi).
- GENERAL NOTES:**  
Designed according to AASHTO LRFD Bridge Design Specifications.  
Do not mount bridge rails of any type directly to these culvert headwalls.  
This standard may not be used for wall heights, H, exceeding the values shown.

Cover dimensions are clear dimensions, unless noted otherwise. Reinforcing dimensions are out-to-out of bars.

**Texas Department of Transportation** Bridge Division Standard

**CONCRETE HEADWALLS WITH FLARED WINGS FOR 0° SKEW PIPE CULVERTS**

**CH-FW-0**

FILE: CD-CH-FW-0-20.dgn	DN: TxDOT	CK: TxDOT	OW: TxDOT	CK: TxDOT
©TxDOT February 2020	CONT	SECT	JOB	HIGHWAY
REVISIONS				
	DIST	COUNTY		SHEET NO.

DATE: FILE: