

DISCLAIMER: The use of this standard is governed by the "Texas Engineering Practice Act." No warranty of any kind is made by TxDOT for any purpose whatsoever. TxDOT assumes no responsibility for the conversion of this standard to other formats or for incorrect results or damages resulting from its use.

TABLE OF VARIABLE DIMENSIONS AND QUANTITIES FOR ONE HEADWALL (5)

Slope	Dia of Pipe (D)	Values for One Pipe				Values to be Added for Each Add'l Pipe				
		W	X	Y	L	Reinf (Lbs)	Conc (CY)	X and W	Reinf (Lbs)	Conc (CY)
2:1	12"	7'-7 3/4"	4'-3"	2'-10"	5'-8"	119	0.9	2'-5 3/4"	26	0.3
	15"	8'-10 1/2"	4'-7 1/4"	3'-4"	6'-8"	135	1.1	3'-0 3/4"	32	0.4
	18"	10'-1 1/4"	4'-11 1/2"	3'-10"	7'-8"	167	1.3	3'-9 1/4"	48	0.5
	21"	11'-3 3/4"	5'-3 3/4"	4'-4"	8'-8"	187	1.6	4'-4 1/4"	54	0.6
	24"	12'-6 1/2"	5'-8"	4'-10"	9'-8"	214	1.8	5'-0 3/4"	67	0.8
	27"	13'-9"	6'-0 1/4"	5'-4"	10'-8"	231	2.1	5'-6 1/2"	73	0.9
	30"	14'-11 3/4"	6'-4 1/2"	5'-10"	11'-8"	265	2.5	6'-1 1/2"	86	1.1
	33"	16'-3"	6'-9 1/2"	6'-4"	12'-8"	292	2.8	6'-7 1/4"	92	1.2
	36"	17'-6 1/4"	7'-2 1/4"	6'-10"	13'-8"	324	3.2	7'-2 1/4"	107	1.4
	42"	20'-1"	8'-0 1/4"	7'-10"	15'-8"	391	4.0	8'-3"	138	1.8
	48"	23'-6"	8'-10 1/4"	9'-4"	18'-8"	478	5.4	9'-3 3/4"	167	2.4
	54"	26'-0 3/4"	9'-8"	10'-4"	20'-8"	561	6.4	10'-7 1/4"	198	3.0
60"	28'-7 1/2"	10'-6"	11'-4"	22'-8"	632	7.5	11'-8"	243	3.6	
66"	31'-2 1/4"	11'-3 3/4"	12'-4"	24'-8"	724	8.8	12'-4 1/2"	269	4.0	
72"	33'-8 3/4"	12'-1 3/4"	13'-4"	26'-8"	803	10.1	13'-2 1/2"	303	4.6	
3:1	12"	10'-1 1/4"	4'-3"	4'-3"	8'-6"	158	1.3	2'-5 3/4"	28	0.3
	15"	11'-9 1/4"	4'-7 1/4"	5'-0"	10'-0"	188	1.6	3'-0 3/4"	37	0.5
	18"	13'-5"	4'-11 1/2"	5'-9"	11'-6"	229	2.0	3'-9 1/4"	55	0.6
	21"	15'-0 3/4"	5'-3 3/4"	6'-6"	13'-0"	260	2.4	4'-4 1/4"	62	0.8
	24"	16'-8 3/4"	5'-8"	7'-3"	14'-6"	297	2.8	5'-0 3/4"	77	1.0
	27"	18'-4 1/2"	6'-0 1/4"	8'-0"	16'-0"	335	3.3	5'-6 1/2"	88	1.2
	30"	20'-0 1/4"	6'-4 1/2"	8'-9"	17'-6"	383	3.9	6'-1 1/2"	103	1.4
	33"	21'-8 3/4"	6'-9 1/2"	9'-6"	19'-0"	421	4.4	6'-7 1/4"	111	1.6
	36"	23'-5 1/2"	7'-2 1/4"	10'-3"	20'-6"	470	5.1	7'-2 1/4"	126	1.9
	42"	26'-10 1/2"	8'-0 1/4"	11'-0"	23'-6"	579	6.4	8'-3"	168	2.4
	48"	31'-7 1/4"	8'-10 1/4"	14'-9"	28'-0"	722	8.7	9'-3 3/4"	210	3.2
	54"	35'-0 1/4"	9'-8"	15'-6"	31'-0"	842	10.5	10'-7 1/4"	249	4.0
60"	38'-5 1/4"	10'-6"	17'-0"	34'-0"	966	12.4	11'-8"	306	4.8	
66"	41'-10 1/4"	11'-3 3/4"	18'-6"	37'-0"	1,106	14.5	12'-4 1/2"	338	5.5	
4:1	12"	12'-6 3/4"	4'-3"	5'-8"	11'-4"	207	1.7	2'-5 3/4"	32	0.4
	15"	14'-7 3/4"	4'-7 1/4"	6'-8"	13'-4"	246	2.2	3'-0 3/4"	43	0.6
	18"	16'-8 3/4"	4'-11 1/2"	7'-8"	15'-4"	300	2.8	3'-9 1/4"	61	0.8
	21"	18'-9 3/4"	5'-3 3/4"	8'-8"	17'-4"	349	3.4	4'-4 1/4"	73	1.0
	24"	20'-10 3/4"	5'-8"	9'-8"	19'-4"	400	4.0	5'-0 3/4"	90	1.3
	27"	23'-0"	6'-0 1/4"	10'-8"	21'-4"	451	4.8	5'-6 1/2"	103	1.5
	30"	25'-1"	6'-4 1/2"	11'-8"	23'-4"	516	5.5	6'-1 1/2"	120	1.8
	33"	27'-2 3/4"	6'-9 1/2"	12'-8"	25'-4"	580	6.4	6'-7 1/4"	134	2.0
	36"	29'-4 1/2"	7'-2 1/4"	13'-8"	27'-4"	639	7.3	7'-2 1/4"	152	2.4
	42"	33'-8"	8'-0 1/4"	15'-8"	31'-4"	789	9.4	8'-3"	198	3.0
	48"	39'-8"	8'-10 1/4"	18'-8"	37'-4"	1,001	12.8	9'-3 3/4"	255	4.0
	6:1	12"	17'-5 3/4"	4'-3"	8'-6"	17'-0"	299	2.9	2'-5 3/4"	38
15"		20'-5"	4'-7 1/4"	10'-0"	20'-0"	371	3.7	3'-0 3/4"	51	0.8
18"		23'-4 1/2"	4'-11 1/2"	11'-6"	23'-0"	449	4.7	3'-9 1/4"	73	1.0
21"		26'-4"	5'-3 3/4"	13'-0"	26'-0"	537	5.8	4'-4 1/4"	89	1.3
24"		29'-3 1/4"	5'-8"	14'-6"	29'-0"	611	7.0	5'-0 3/4"	110	1.7
27"		32'-2 3/4"	6'-0 1/4"	16'-0"	32'-0"	708	8.3	5'-6 1/2"	129	2.0
30"		35'-2 1/4"	6'-4 1/2"	17'-6"	35'-0"	807	9.7	6'-1 1/2"	150	2.4
33"		38'-2 1/4"	6'-9 1/2"	19'-0"	38'-0"	921	11.3	6'-7 1/4"	170	2.8

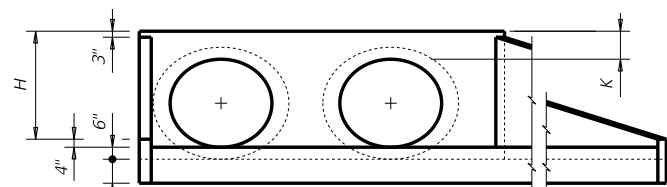

ELEVATION

(Showing dimensions.)

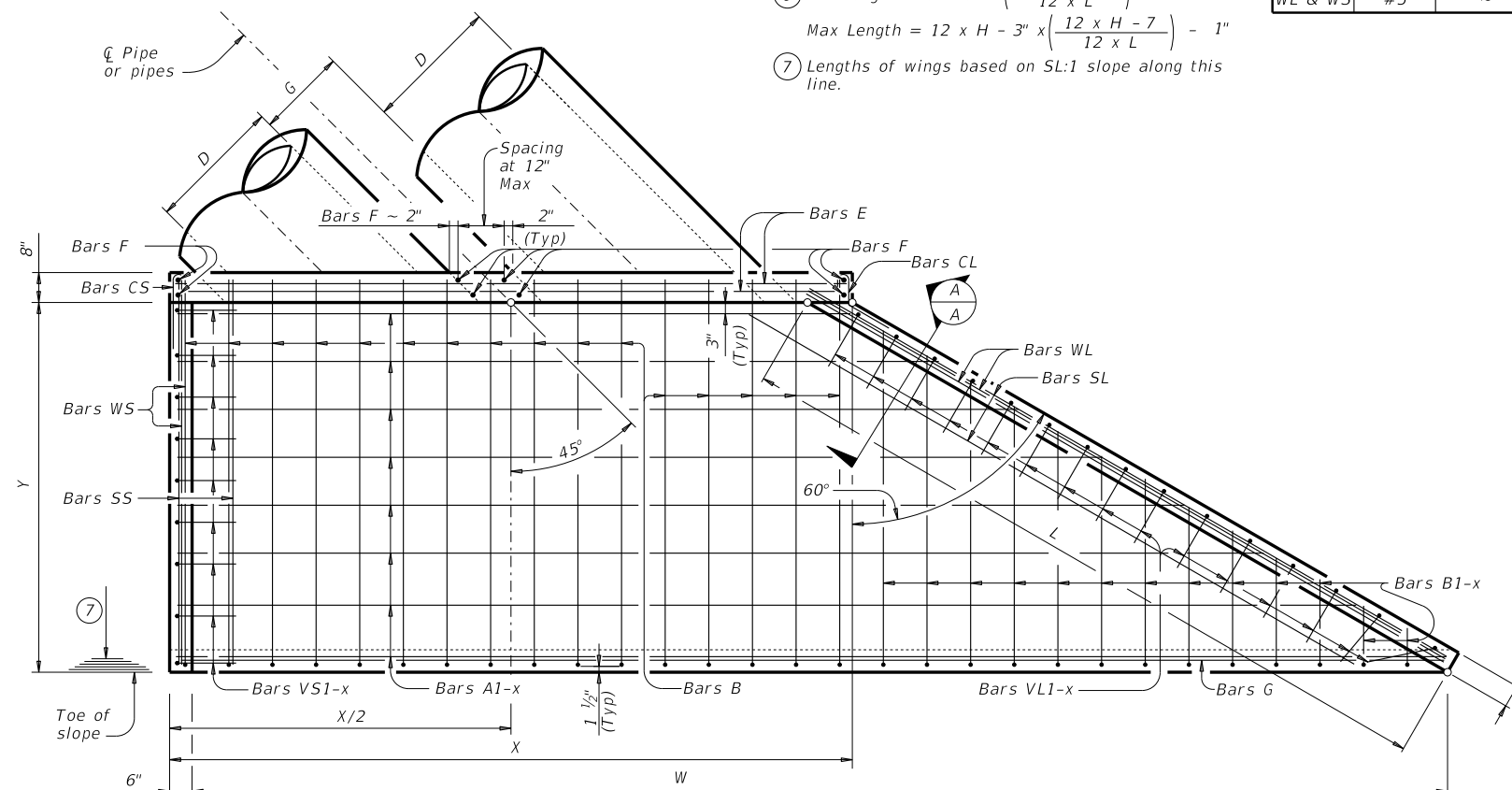

PLAN

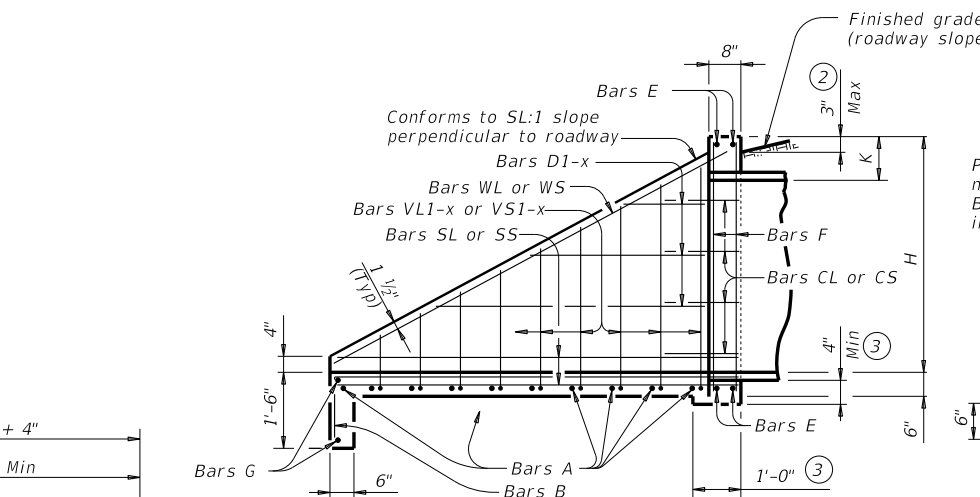

TYPICAL WING ELEVATION

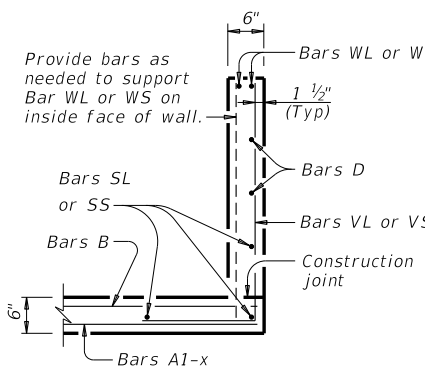

SECTION A-A

- Quantities shown are for concrete pipe and will increase slightly for metal pipe installations.
- For vehicle safety, construct curbs no more than 3" above finished grade. Reduce curb heights, if necessary, to meet these requirements. No changes will be made in quantities and no additional compensation will be allowed for this work.
- Provide a 1'-0" footing as shown where required to maintain 4" minimum cover for pipes.
- Dimensions shown are usual and maximum.
- Quantities shown are for one structure end only (one headwall).
- Min Length = $6" + 3" \times \left(\frac{12 \times H - 7}{12 \times L} \right)$
Max Length = $12 \times H - 3" \times \left(\frac{12 \times H - 7}{12 \times L} \right) - 1"$
- Lengths of wings based on SL:1 slope along this line.

TABLE OF REINFORCING STEEL (5)

Bar	Size	Spa	No.
A	#4	1'-0"	~
B	#3	1'-6"	~
CL & CS	#4	1'-0"	~
D	#3	1'-0"	~
E	#5	~	4
F	#5	~	~
G	#3	~	2
SL & SS	#4	~	6
VL & VS	#4	1'-0"	~
WL & WS	#5	~	4

TABLE OF CONSTANT DIMENSIONS

Dia of Pipe (D)	G	K (4)	H
12"	0'-9"	1'-0"	2'-0"
15"	0'-11"	1'-0"	2'-3"
18"	1'-2"	1'-0"	2'-6"
21"	1'-4"	1'-0"	2'-9"
24"	1'-7"	1'-0"	3'-0"
27"	1'-8"	1'-0"	3'-3"
30"	1'-10"	1'-0"	3'-6"
33"	1'-11"	1'-0"	3'-9"
36"	2'-1"	1'-0"	4'-0"
42"	2'-4"	1'-0"	4'-6"
48"	2'-7"	1'-3"	5'-3"
54"	3'-0"	1'-3"	5'-9"
60"	3'-3"	1'-3"	6'-3"
66"	3'-3"	1'-3"	6'-9"
72"	3'-4"	1'-3"	7'-3"

MATERIAL NOTES:
Provide Grade 60 reinforcing steel.
Provide Class C concrete (f'c = 3,600 psi).

GENERAL NOTES:
Designed according to AASHTO LRFD Bridge Design Specifications.
Do not mount bridge rails of any type directly to these culvert headwalls.
This standard may not be used for wall heights, H, exceeding the values shown.

Cover dimensions are clear dimensions, unless noted otherwise. Reinforcing dimensions are out-to-out of bars.

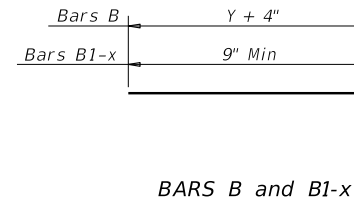
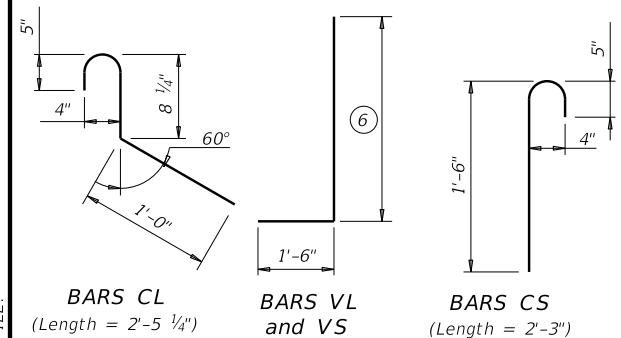

Texas Department of Transportation Bridge Division Standard

CONCRETE HEADWALLS WITH FLARED WINGS FOR 45° SKEW PIPE CULVERTS

CH-FW-45

FILE: CD-CH-FW45-20.dgn ON: TxDOT CK: TxDOT DW: TxDOT CK: TxDOT
 ©TxDOT February 2020 CONT SECT JOB HIGHWAY
 REVISIONS DIST COUNTY SHEET NO.

DATE: FILE: