

DISCLAIMER: The use of this standard is governed by the "Texas Engineering Practice Act." No warranty of any kind is made by TxDOT for any purpose whatsoever. TxDOT assumes no responsibility for the conversion of this standard to other formats or for incorrect results or damages resulting from its use.

**TABLE OF VARIABLE DIMENSIONS AND QUANTITIES FOR ONE HEADWALL (6)**

Slope	Size of Pipe Arch		Values for One Pipe						Values to be Added for Each Add'l Pipe			
	Span	Rise	W	X	Y	L	Reinf (Lbs)	Conc (CY) (1)	X and W	Reinf (Lbs)	Conc (CY) (1)	
2:1	1	17"	13"	3'-7 1/2"	2'-11 1/2"	3'-0"	3'-5 1/2"	93	0.6	2'-6"	36	0.3
	2	21"	15"	4'-2"	3'-3 3/4"	3'-4"	3'-10 1/4"	105	0.7	3'-0 1/4"	43	0.4
	3	28"	20"	5'-3"	3'-11"	4'-2"	4'-9 3/4"	143	1.0	3'-10 1/2"	60	0.6
	4	35"	24"	6'-2 3/4"	4'-6 1/4"	4'-10"	5'-7"	168	1.2	4'-9"	76	0.8
	5	42"	29"	7'-3 3/4"	5'-1 1/2"	5'-8"	6'-6 1/2"	200	1.6	5'-7 1/4"	101	1.1
	6	49"	33"	8'-3 3/4"	5'-8 3/4"	6'-4"	7'-3 3/4"	231	1.9	6'-5 3/4"	115	1.3
	7	57"	38"	9'-5 3/4"	6'-5"	7'-2"	8'-3 1/4"	266	2.4	7'-5"	137	1.7
	8	64"	43"	10'-6 3/4"	7'-0 1/4"	8'-0"	9'-2 3/4"	310	2.8	8'-5 1/2"	172	2.1
	9	71"	47"	11'-6 1/2"	7'-7 1/2"	8'-8"	10'-0"	350	3.3	9'-4 3/4"	197	2.5
3:1	1	17"	13"	4'-5 3/4"	2'-11 1/2"	4'-6"	5'-2 1/4"	121	0.8	2'-6"	38	0.4
	2	21"	15"	5'-1 1/2"	3'-3 3/4"	5'-0"	5'-9 1/4"	136	1.0	3'-0 1/4"	48	0.5
	3	28"	20"	6'-5 1/2"	3'-11"	6'-3"	7'-2 1/2"	185	1.4	3'-10 1/2"	67	0.8
	4	35"	24"	7'-7 1/2"	4'-6 1/4"	7'-3"	8'-4 1/2"	220	1.8	4'-9"	85	1.0
	5	42"	29"	8'-11 1/2"	5'-1 1/2"	8'-6"	9'-9 3/4"	272	2.3	5'-7 1/4"	116	1.4
	6	49"	33"	10'-1 1/2"	5'-8 3/4"	9'-6"	10'-11 3/4"	310	2.8	6'-5 3/4"	134	1.7
	7	57"	38"	11'-6 1/2"	6'-5"	10'-9"	12'-5"	362	3.5	7'-5"	164	2.2
	8	64"	43"	12'-10 1/2"	7'-0 1/4"	12'-0"	13'-10 1/4"	426	4.2	8'-5 1/2"	203	2.7
	9	71"	47"	14'-0 3/4"	7'-7 1/2"	13'-0"	15'-0 1/4"	472	4.9	9'-4 3/4"	233	3.2
4:1	1	17"	13"	5'-4 1/4"	2'-11 1/2"	6'-0"	6'-11"	151	1.1	2'-6"	43	0.5
	2	21"	15"	6'-1"	3'-3 3/4"	6'-8"	7'-8 1/2"	171	1.3	3'-0 1/4"	54	0.6
	3	28"	20"	7'-7 3/4"	3'-11"	8'-4"	9'-7 1/2"	230	1.8	3'-10 1/2"	74	0.9
	4	35"	24"	9'-0 1/4"	4'-6 1/4"	9'-8"	11'-2"	280	2.4	4'-9"	98	1.2
	5	42"	29"	10'-7"	5'-1 1/2"	11'-4"	13'-1"	336	3.1	5'-7 1/4"	127	1.7
	6	49"	33"	11'-11 1/2"	5'-8 3/4"	12'-8"	14'-7 1/2"	399	3.8	6'-5 3/4"	156	2.1
	7	57"	38"	13'-7 1/2"	6'-5"	14'-4"	16'-6 3/4"	461	4.7	7'-5"	185	2.7
	8	64"	43"	15'-2 1/4"	7'-0 1/4"	16'-0"	18'-5 3/4"	546	5.7	8'-5 1/2"	233	3.3
	9	71"	47"	16'-6 3/4"	7'-7 1/2"	17'-4"	20'-0 1/4"	605	6.7	9'-4 3/4"	269	4.0
6:1	1	17"	13"	7'-1"	2'-11 1/2"	9'-0"	10'-4 3/4"	212	1.6	2'-6"	49	0.6
	2	21"	15"	8'-0"	3'-3 3/4"	10'-0"	11'-6 1/2"	240	2.0	3'-0 1/4"	62	0.8
	3	28"	20"	10'-0 3/4"	3'-11"	12'-6"	14'-5 1/4"	336	2.9	3'-10 1/2"	91	1.2
	4	35"	24"	11'-9 3/4"	4'-6 1/4"	14'-6"	16'-9"	395	3.7	4'-9"	117	1.7
	5	42"	29"	13'-10 1/4"	5'-1 1/2"	17'-0"	19'-7 1/2"	497	5.0	5'-7 1/4"	158	2.2
	6	49"	33"	15'-7 1/2"	5'-8 3/4"	19'-0"	21'-11 1/4"	588	6.1	6'-5 3/4"	192	2.8
	7	57"	38"	17'-9"	6'-5"	21'-6"	24'-10"	697	7.6	7'-5"	238	3.7
	8	64"	43"	19'-9 1/2"	7'-0 1/4"	24'-0"	27'-8 1/2"	816	9.3	8'-5 1/2"	297	4.6
	9	71"	47"	21'-6 3/4"	7'-7 1/2"	26'-0"	30'-0 1/4"	920	10.9	9'-4 3/4"	347	5.5

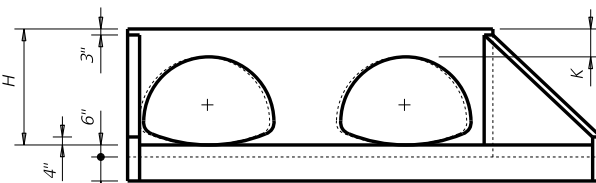

**ELEVATION**

(Showing dimensions.)

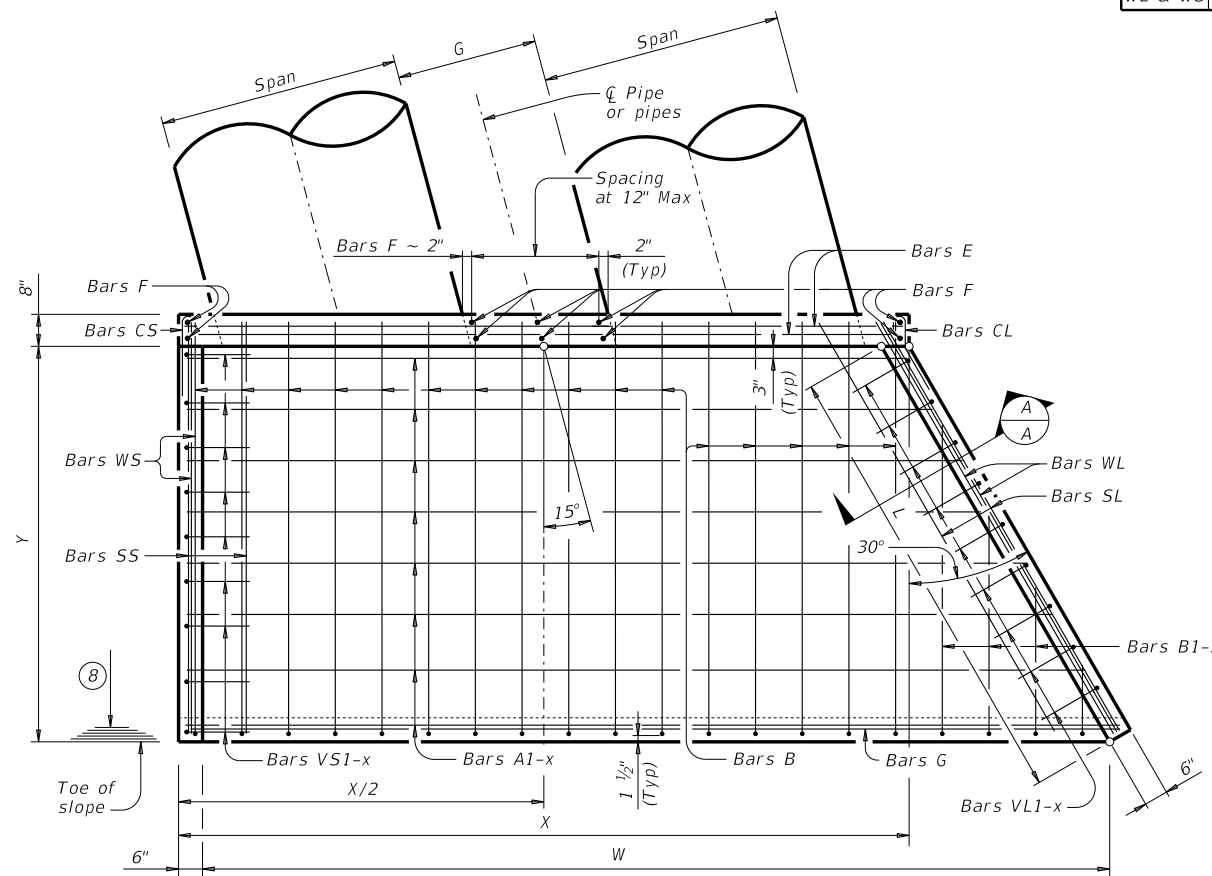

**PLAN**

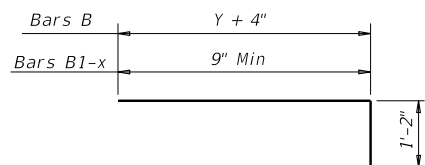

**BARS B and B1-x**

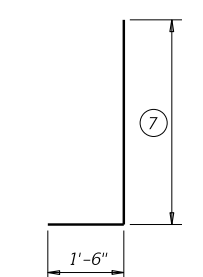

**BARS VL and VS**

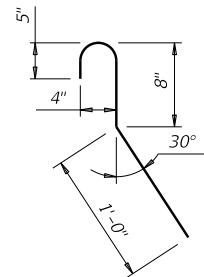

**BARS CL**  
(Length = 2'-5")

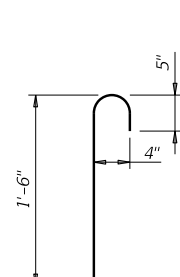

**BARS CS**  
(Length = 2'-3")

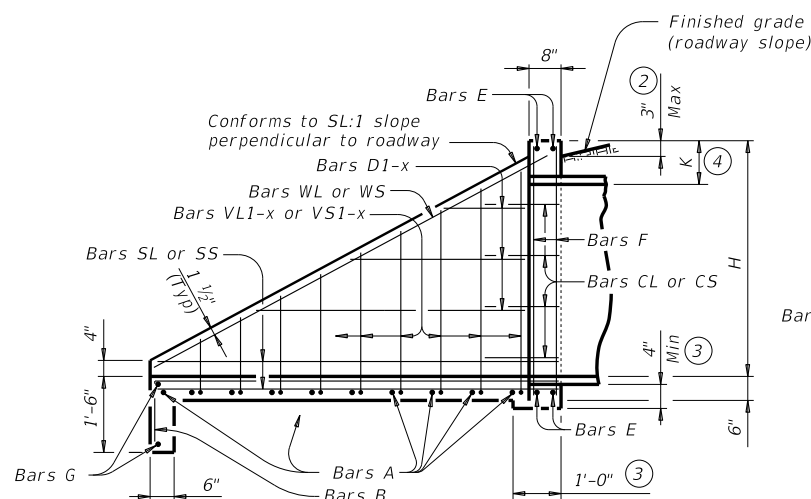

**TYPICAL WING ELEVATION**

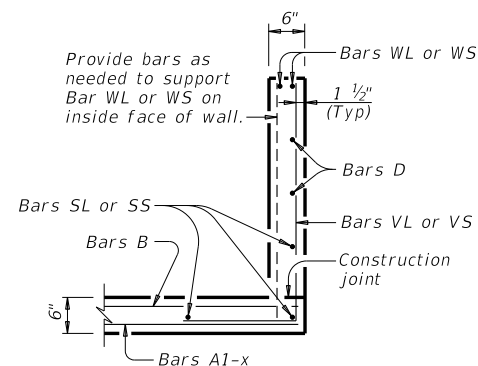

**SECTION A-A**

**TABLE OF REINFORCING STEEL (6)**

Bar	Size	Spa	No.
A	#4	1'-0"	~
B	#3	1'-6"	~
CL & CS	#4	1'-0"	~
D	#3	1'-0"	~
E	#5	~	4
F	#5	~	~
G	#3	~	2
SL & SS	#4	~	6
VL & VS	#4	1'-0"	~
WL & WS	#5	~	4

**TABLE OF CONSTANT DIMENSIONS**

Design	Size of Pipe Arch		G	K (5)	H
	Span	Rise			
1	17"	13"	1'-0"	1'-0"	2'-1"
2	21"	15"	1'-0"	1'-0"	2'-3"
3	28"	20"	1'-5"	1'-0"	2'-8"
4	35"	24"	1'-8"	1'-0"	3'-0"
5	42"	29"	1'-11"	1'-0"	3'-5"
6	49"	33"	2'-2"	1'-0"	3'-9"
7	57"	38"	2'-5"	1'-0"	4'-2"
8	64"	43"	2'-10"	1'-0"	4'-7"
9	71"	47"	3'-2"	1'-0"	4'-11"

(1) Quantities shown are for metal pipe and will increase slightly for concrete pipe installations.

(2) For vehicle safety, construct curbs no more than 3" above finished grade. Reduce curb heights, if necessary, to meet these requirements. No changes will be made in quantities and no additional compensation will be allowed for this work.

(3) Provide a 1'-0" footing as shown where required to maintain 4" minimum cover for pipes.

(4) K is measured from top of curb to inside face of pipe.

(5) Dimensions shown are usual and maximum.

(6) Quantities shown are for one structure end only (one headwall).

(7) Min Length =  $6' + 3" \times \left( \frac{12 \times H - 7}{12 \times L} \right)$   
Max Length =  $12 \times H - 3" \times \left( \frac{12 \times H - 7}{12 \times L} \right) - 1"$

(8) Lengths of wings based on SL:1 slope along this line.

**MATERIAL NOTES:**

Provide Grade 60 reinforcing steel.  
Provide Class C concrete (f'c = 3,600 psi).

**GENERAL NOTES:**

Designed according to AASHTO LRFD Bridge Design Specifications.  
Do not mount bridge rails of any type directly to these culvert headwalls.  
This standard may not be used for wall heights, H, exceeding the values shown.

Cover dimensions are clear dimensions, unless noted otherwise. Reinforcing dimensions are out-to-out of bars.



**CONCRETE HEADWALLS WITH FLARED WINGS FOR 15° SKEW ARCH PIPE CULVERTS**

**CH-FW-A-15**

FILE: CD-CH-FWA15-20.dgn	DN: TxDOT	CK: TxDOT	OW: TxDOT	CK: TxDOT
©TxDOT February 2020	CONT	SECT	JOB	HIGHWAY
REVISIONS				
	DIST	COUNTY		SHEET NO.

DATE: FILE: