

DISCLAIMER: The use of this standard is governed by the "Texas Engineering Practice Act." No warranty of any kind is made by TxDOT for any purpose whatsoever. TxDOT assumes no responsibility for the conversion of this standard to other formats or for incorrect results or damages resulting from its use.

DATE: FILE:

TABLE OF DIMENSIONS AND REINFORCING STEEL
(Wings for one structure end)

Maximum Wingwall Height Hw	Dimensions				Variable Reinforcing				Estimated Quantities per ft of wing length (2-wings) (3)	
	W	X	Y	Z	Bars J1		Bars J2		Reinf (Lb/Ft)	Conc (CY/Ft)
					Size	Spa	Size	Spa		
2'-6"	2'-5"	1'-0"	9"	7"	#4	1'-0"	#4	1'-0"	33.73	0.248
3'-0"	2'-5"	1'-0"	9"	7"	#4	1'-0"	#4	1'-0"	37.07	0.261
3'-6"	2'-5"	1'-0"	9"	7"	#4	1'-0"	#4	1'-0"	37.74	0.273
4'-0"	2'-5"	1'-0"	9"	7"	#4	1'-0"	#4	1'-0"	38.41	0.285
4'-6"	3'-2"	1'-6"	1'-0"	7"	#4	1'-0"	#4	1'-0"	41.75	0.330
5'-0"	3'-2"	1'-6"	1'-0"	7"	#4	1'-0"	#4	1'-0"	45.09	0.343
5'-6"	3'-2"	1'-6"	1'-0"	7"	#4	1'-0"	#4	1'-0"	45.75	0.355
6'-0"	3'-2"	1'-6"	1'-0"	7"	#4	1'-0"	#4	1'-0"	46.42	0.367
7'-0"	3'-8"	1'-9"	1'-3"	7"	#4	1'-0"	#4	1'-0"	52.77	0.414
8'-0"	4'-2"	2'-0"	1'-6"	8"	#5	1'-0"	#4	1'-0"	60.19	0.486
9'-0"	4'-8"	2'-3"	1'-9"	8"	#4	6"	#4	6"	81.49	0.535
10'-0"	5'-2"	2'-6"	2'-0"	8"	#5	6"	#4	6"	97.25	0.584
11'-0"	5'-8"	2'-9"	2'-3"	8"	#6	6"	#5	6"	133.65	0.634
12'-0"	6'-2"	3'-0"	2'-6"	9"	#7	6"	#5	6"	162.29	0.721
13'-0"	6'-8"	3'-3"	2'-9"	11"	#7	6"	#5	6"	178.80	0.856
14'-0"	7'-2"	3'-6"	3'-0"	1'-0"	#8	6"	#5	6"	216.78	0.959
15'-0"	7'-8"	4'-0"	3'-0"	1'-1"	#9	6"	#6	6"	283.06	1.068
16'-0"	8'-2"	4'-6"	3'-0"	1'-3"	#9	6"	#6	6"	297.02	1.234

TABLE OF WINGWALL REINFORCING
(2-wings)

Bar	Size	No.	Spa
D	#5	~	1'-0"
E	#4	~	1'-0"
F	#4	~	1'-0"
G	#6	4	~
M	#4	4	~
P	#4	~	1'-0"
R	#5	6	~
V	#4	~	1'-0"

TABLE OF ESTIMATED CULVERT TOEWALL QUANTITIES

Bar	Size	No.	Spa
L	#4	~	1'-6"
Q	#4	1	~
Reinf (Lb/Ft)			2.45
Conc (CY/Ft)			0.037

WING DIMENSION FORMULAS:

(All values are in feet.)

$Hw = H + T + C - 0.250'$
 $A = (Hw - 0.333') (SL)$
 $B = (A) \text{ tangent } (30^\circ)$
 $Lw = (A) \div \text{cosine } (30^\circ)$

For cast-in-place culverts:
 $Ltw = (N) (S) + (N + 1) (U)$

For precast culverts:
 $Ltw = (N) (2U + S) + (N - 1) (0.5')$

Total wingwall area (two wings ~ SF) = $(Hw + 0.333') (Lw)$

Hw = Height of wingwall
 $SL:1$ = Side slope ratio (horizontal:1 vertical)
 Lw = Length of wingwall
 Ltw = Culvert toewall length
 N = Number of culvert spans

See applicable box culvert standard sheet for H, S, T, and U values.

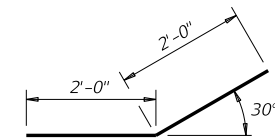

BARS D

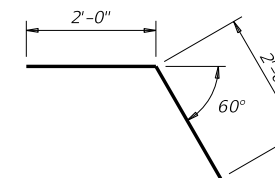

BARS R

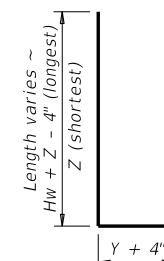

BARS J1

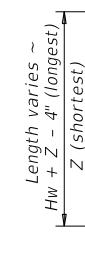

BARS V

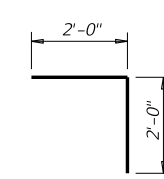

BARS L

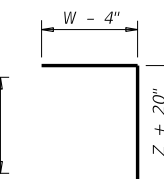

BARS J2

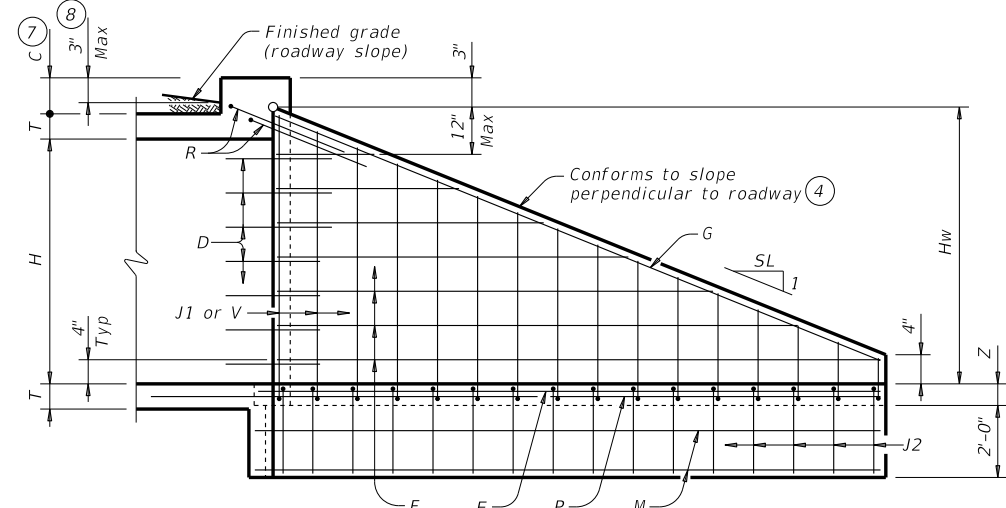

INSIDE ELEVATION

(Showing reinforcing. Culvert and culvert toewall reinforcing not shown for clarity.)

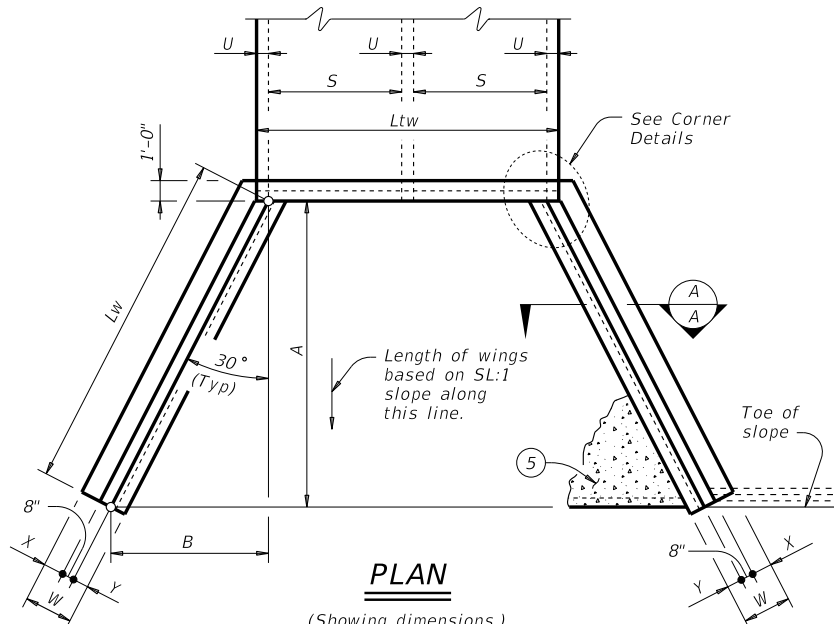

PLAN

(Showing dimensions.)

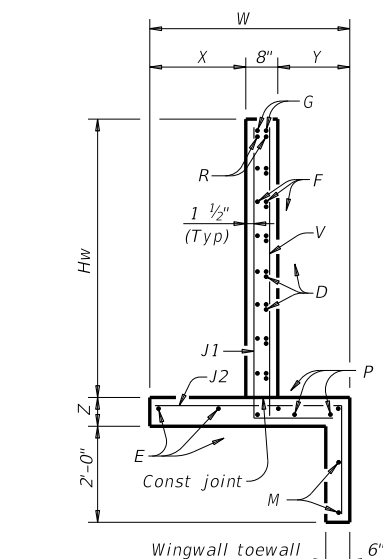

SECTION A-A

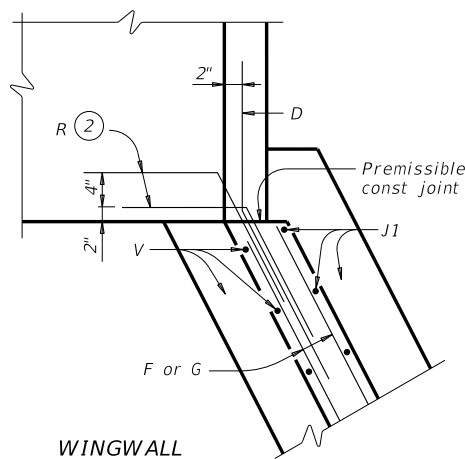

WINGWALL

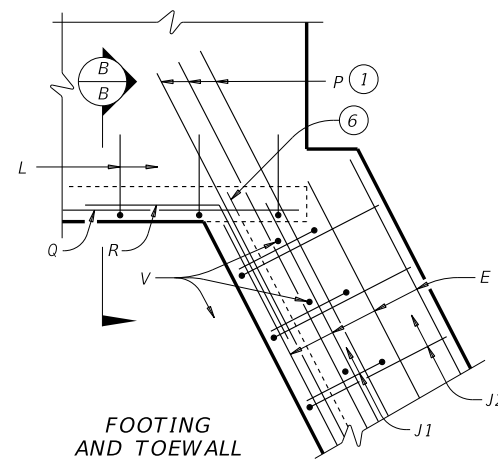

FOOTING AND TOEWALL

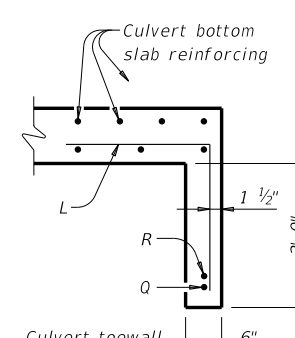

SECTION B-B (5)

- Extend Bars P 3'-0" minimum into bottom slab of box culvert.
- Adjust as necessary to maintain 1 #2" clear cover and 4" minimum between bars.
- Quantities shown are based on an average wing height for two wings (one structure end). To determine total quantities for two wings, multiply the tabulated values by Lw.
- Recommended values of side slope are: 2:1, 3:1, 4:1, and 6:1.
- When shown elsewhere on the plans, construct 5" deep concrete riprap. Payment for riprap is as required by Item 432, "Riprap." Unless otherwise shown on the plans or directed by the Engineer, provide a 6" wide by 1'-6" deep reinforced concrete toewall along all edges of the riprap adjacent to natural ground; reinforce the toewall by extending typical riprap reinforcing into the toewall; and extend construction joints or grooved joints oriented in the direction of flow across the full distance of the riprap at intervals of approximately 20'. When such riprap is provided, the culvert toewall shown in SECTION B-B will not be required.
- At Contractor's option, culvert toewall may be ended flush with wingwall toewall. Adjust reinforcing as needed.
- 0" Min to 5'-0" Max. Estimated curb heights are shown elsewhere in the plans. For structures with pedestrian rail or curbs taller than 1'-0", refer to the Extended Curb Details (ECD) standard sheet. For structures with T631 or T631LS bridge rail, refer to the Mounting Details for T631 & T631LS Rails (T631-CM) standard sheet. Refer to the Box Culvert Rail Mounting Details (RAC) standard sheet for structures with bridge rail other than T631 or T631LS.
- For vehicle safety, the following requirements must be met:
 - For structures without bridge rail, construct curbs no more than 3" above finished grade.
 - For structures with bridge rail, construct curbs flush with finished grade.
 Reduce curb heights, if necessary, to meet the above requirements. No changes will be made in quantities and no additional compensation will be allowed for this work.

MATERIAL NOTES:
 Provide Class C concrete (f'c=3,600 psi).
 Provide Grade 60 reinforcing steel.
 Provide galvanized reinforcing steel if required elsewhere in the plans.
 In riprap concrete synthetic fibers listed on the "Fibers for Concrete" Material Producer List (MPL) may be used in lieu of steel reinforcing unless noted otherwise.

GENERAL NOTES:
 Designed according to AASHTO LRFD Bridge Design Specifications.
 When structure is founded on solid rock, depth of toewalls for culverts and wingwalls may be reduced or eliminated as directed by the Engineer.
 See Box Culvert Supplement (BCS) standard sheet for additional dimensions and information.
 The quantities for concrete and reinforcing steel resulting from the formulas given on this sheet are for Contractor's information only.

Cover dimensions are clear dimensions, unless noted otherwise. Reinforcing dimensions are out-to-out of bars.

Texas Department of Transportation Bridge Division Standard

CONCRETE WINGWALLS WITH FLARED WINGS FOR 0° SKEW BOX CULVERTS

FW-0

FILE: CD-FW0-20.dgn	DN: GAF	CK: CAT	DW: TxDOT	CK: TxDOT
©TxDOT February 2020	CONT	SECT	JOB	HIGHWAY
REVISIONS				
	DIST	COUNTY		SHEET NO.