

DISCLAIMER: The use of this standard is governed by the "Texas Engineering Practice Act." No warranty of any kind is made by TxDOT for any purpose whatsoever. TxDOT assumes no responsibility for the conversion of this standard to other formats or for incorrect results or damages resulting from its use.

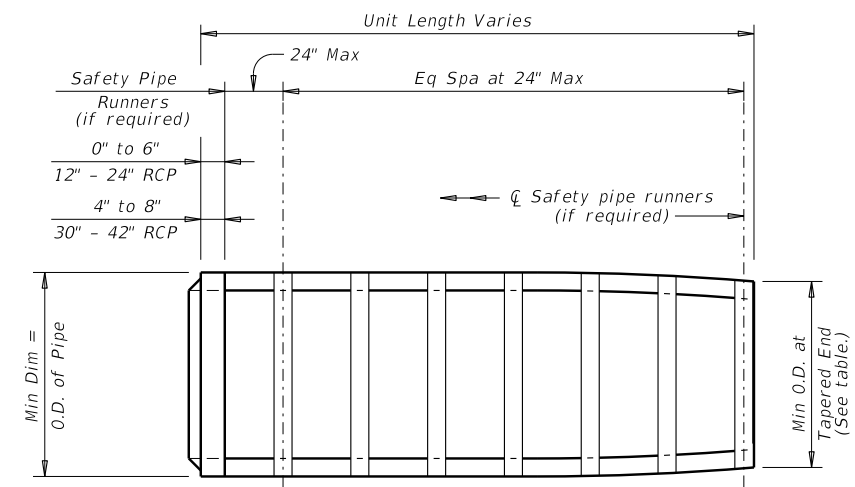

PLAN VIEW - 12" THRU 24"

(Showing spigot end connection.)

- ① Slope as shown elsewhere in the plans. Slope of 6:1 or flatter is required for vehicle safety.
- ② Provide cement stabilized bedding and backfill in accordance with the Item, "Excavation and Backfill for Structures." Bedding and backfill is considered subsidiary to the Item 467, "Safety End Treatment." When concrete riprap is specified around the safety end treatment, backfill as directed by Engineer.
- ③ Fill the top 4" of void between precast end treatments with concrete riprap. Concrete riprap is considered subsidiary to the Item 467, "Safety End Treatment."
- ④ Adjust clear distance between pipes to provide for the minimum distance between safety end treatments.
- ⑤ Safety pipe runners are required for multiple pipe culverts with more than two pipes.

REQUIREMENTS FOR CULVERT PIPES AND SAFETY PIPE RUNNERS											
Pipe I.D.	Min Wall Thickness	Min O.D.	Min O.D. at Tapered End	Min Reinf Requirements (sq. in. per ft. of Pipe)	Max Slope	Min Length of Unit	Pipe Runner Requirements		Required Pipe Runner Sizes		
							Single Pipe	Multiple Pipe	Nominal Dia	O.D.	I.D.
12"	2"	16"	16"	0.07 Circ.	6:1	4'-0"	No	(5)	3" STD	3.500"	3.068"
15"	2 1/4"	19 1/2"	19"	0.07 Circ.	6:1	5'-8"	No	(5)	3" STD	3.500"	3.068"
18"	2 1/2"	23"	21 1/2"	0.07 Circ.	6:1	7'-3"	No	(5)	3" STD	3.500"	3.068"
24"	3"	30"	27"	0.07 Circ.	6:1	10'-6"	No	(5)	3" STD	3.500"	3.068"
30"	3 1/2"	37"	31"	0.18 Circ.	6:1	12'-1"	No	Yes	4" STD	4.500"	4.026"
36"	4"	44"	36"	0.19 Ellip.	6:1	15'-4"	Yes	Yes	4" STD	4.500"	4.026"
42"	4 1/2"	51"	41 1/2"	0.23 Ellip.	6:1	18'-7"	Yes	Yes	4" STD	4.500"	4.026"

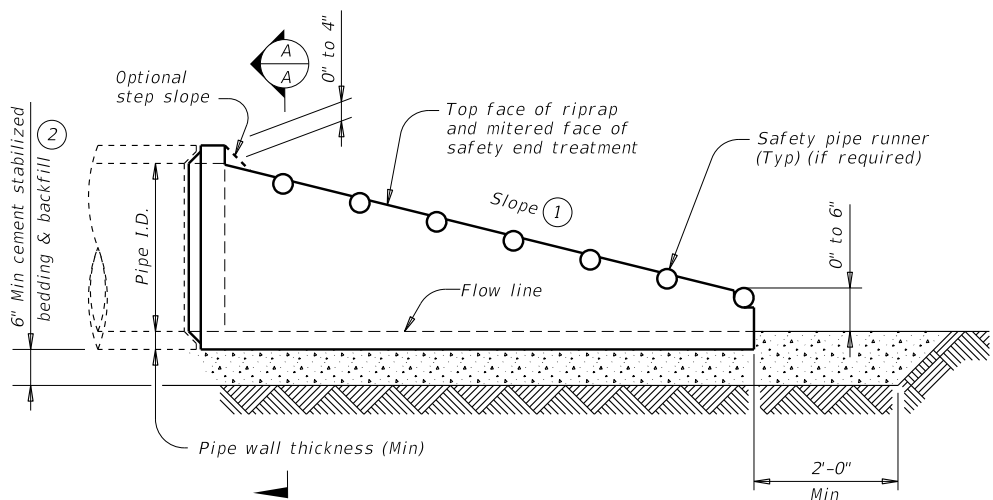

LONGITUDINAL ELEVATION - 12" THRU 24"

(Showing spigot end connection.)

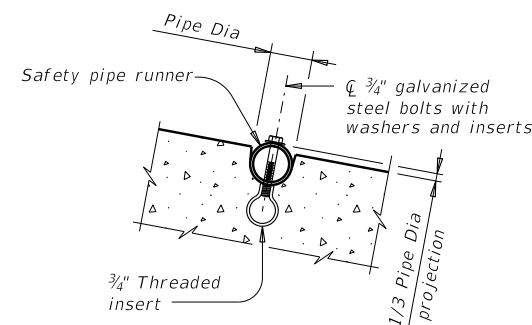

INSTALLATION DETAIL FOR SAFETY PIPE RUNNERS

(If required)

MATERIAL NOTES:
 Synthetic fibers listed on the "Fibers for Concrete" Material Producer List (MPL) may be used in lieu of steel reinforcing in riprap concrete unless noted otherwise.
 Provide pipe runners meeting the requirements of ASTM A53 (Type E or S, Gr B), ASTM A500 Gr B, or API 5LX52.
 Galvanize steel components except reinforcing steel after fabrication. Repair galvanizing damaged during transport or construction in accordance with the specifications.

GENERAL NOTES:
 Precast safety end treatment for reinforced concrete pipe (RCP) may be used for TYPE II end treatment as specified in Item 467, "Safety End Treatment."
 When precast safety end treatment is used as a Contractor's alternate to mitered RCP, riprap will not be required unless noted otherwise on the plans.
 Manufacture precast concrete end sections in accordance with Item 464, "Reinforced Concrete Pipe" and in accordance with ASTM Specification C-76, Class III, Wall B for circular pipe.
 Provide precast concrete end sections with a spigot or bell end for compatibility to upstream or downstream end conditions with sufficient annular space to allow for grout, mortar, cold applied asphalt joint compound or pre-formed plastic gasket material.
 Methods of lifting shall be provided by the manufacturer for ease of loading, unloading and installation.
 Pipe runners are designed for a traversing load of 10,000 Lbs at yield as recommended by Research Report 280-2F, "Safety Treatment of Roadside Parallel-Drainage Structures", Texas Transportation Institute, March 1981.

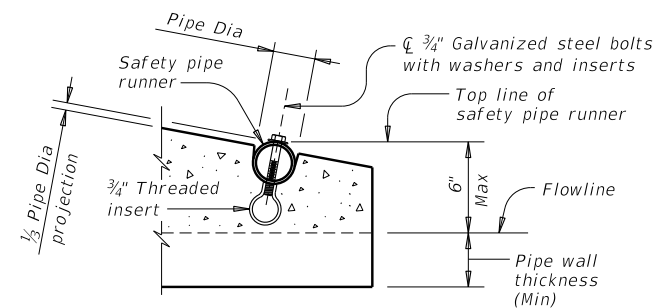

OPTION A

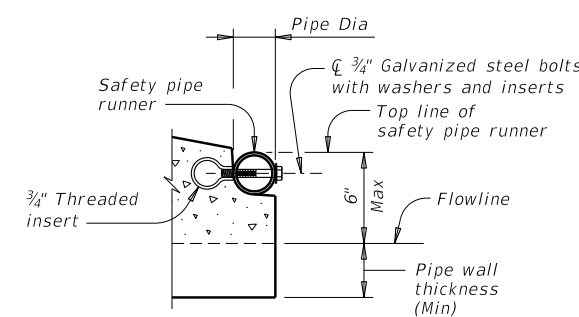

OPTION B

END DETAILS FOR INSTALLATION OF SAFETY PIPE RUNNERS

(If required)

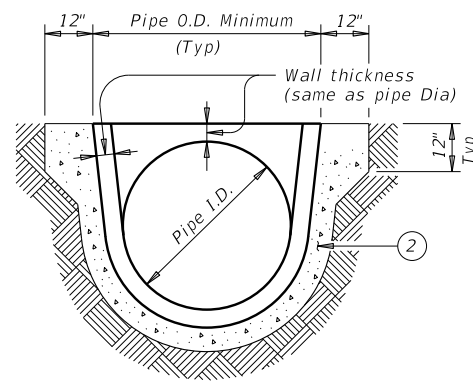

SECTION A-A

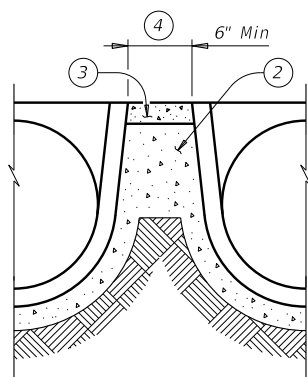

MULTIPLE PIPE INSTALLATION

				Bridge Division Standard	
PRECAST SAFETY END TREATMENT TYPE II ~ PARALLEL DRAINAGE					
PSET-RP					
FILE: CD-PSET-RP-20.dgn	DN: RLW	CK: KLR	DW: JTR	CK: GAF	
©TxDOT February 2020	CONT	SECT	JOB	HIGHWAY	
REVISIONS					
	DIST	COUNTY		SHEET NO.	

DATE: FILE: