

DISCLAIMER: The use of this standard is governed by the "Texas Engineering Practice Act." No warranty of any kind is made by TxDOT for any purpose whatsoever. TxDOT assumes no responsibility for the conversion of this standard to other formats or for incorrect results or damages resulting from its use.

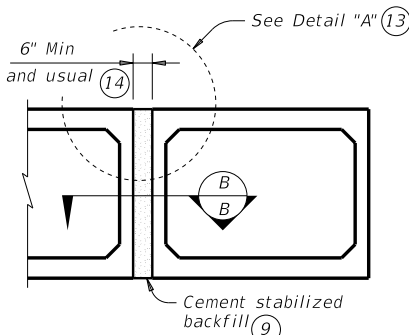

MULTIPLE UNIT PLACEMENT

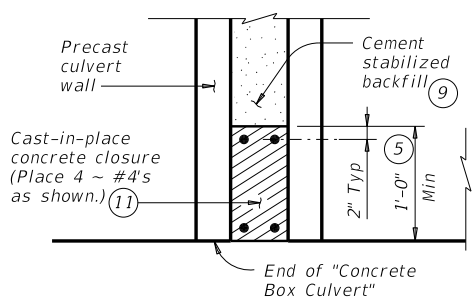

SECTION B-B

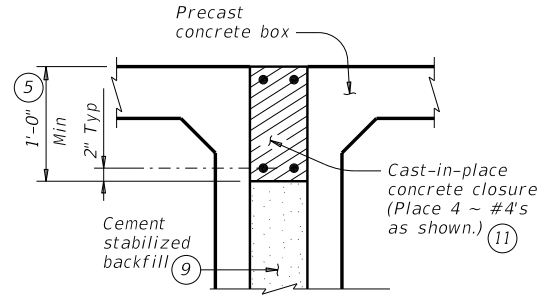

DETAIL "A" (13)

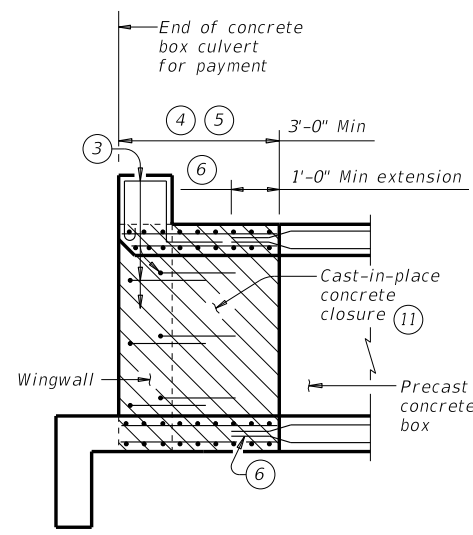

WINGWALL CONNECTION

(Also applies to safety end treatment.)

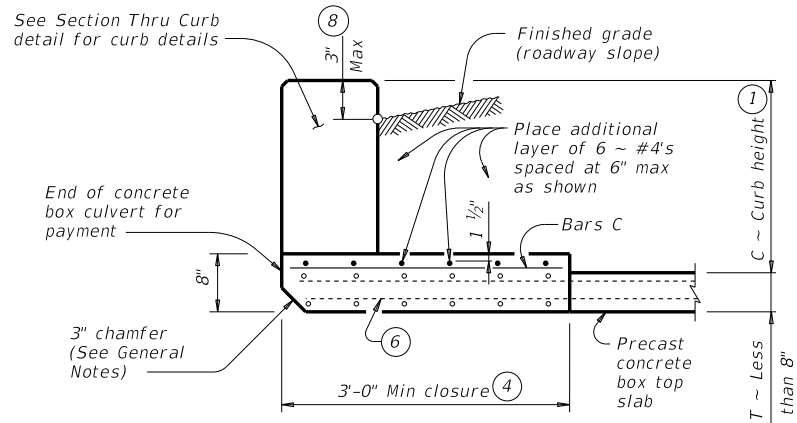

SECTION THRU TOP SLABS LESS THAN 8"

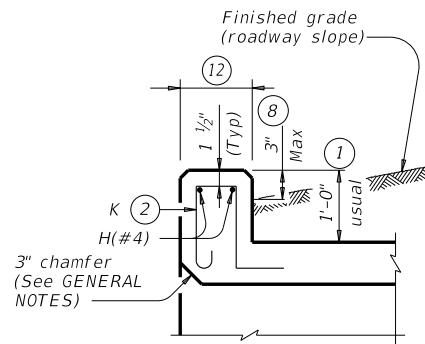

SECTION THRU CURB

QUANTITIES PER FOOT OF CURB (10)	
Reinforcing Steel	4.12 Lb
Concrete	0.037 CY

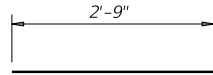

BARS C (#4)
(Spa = 1'-0" Max)

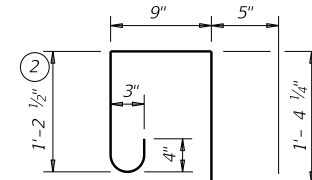

BARS K (#4)
(Spa = 1'-0" Max)
(Length = 4'-2")

- 0" Min to 5'-0" Max. Estimated curb heights are shown elsewhere in the plans. For structures with pedestrian rail, bicycle rail, or curbs taller than 1'-0, refer to the Extended Curb Details (ECD) standard sheet. For structures with T631 or T631LS bridge rail, refer to the Mounting Details for T631 & T631LS Rails (T631-CM) standard sheet. Refer to the Box Culvert Rail Mounting Details (RAC) standard sheet for structures with bridge rail other than T631 or T631LS.
- For curbs less than 1'-0" high, tilt Bars K or reduce bar height as necessary to maintain cover. For curbs less than 3" high, Bars K may be omitted.
- Extend curb, wingwall, or safety end treatment reinforcing into concrete closure. Bend or trim, as necessary, any reinforcing that does not fit into closure area.
- Provide a 3'-0" Min cast-in-place concrete closure. Break back boxes in the field or cast boxes short. Provide bands of reinforcing in the closure that are the same size and spacing as in the precast box section. Provide #4 longitudinal reinforcement spaced at 12 inches Max within the closure. Except where shown otherwise, construct the cast-in-place closure flush with the inside and outside faces of the precast box section.
- For multiple unit placements, adjust the length of the closure for the interior walls as necessary. Provide a 3'-0" Min cast-in-place closure in the top slab, bottom slab, and exterior wall. See Section B-B detail when interior walls are cast full length.
- Extend precast box reinforcing a minimum of 1'-0" into concrete closure (Typ).
- Place bands of reinforcing matching the inside and outside face reinforcing in the gaps of the top and bottom slabs. Place a band matching the outside face reinforcing of the wall in the gaps of the walls (placed in the outside face only). Tack weld the bands to the exposed reinforcing at each point of contact.
- For vehicle safety, the following requirements must be met:
 - For structures without bridge rail, construct curbs no more than 3" above finished grade.
 - For structures with bridge rail, construct curbs flush with finished grade. Reduce curb heights, if necessary, to meet the above requirements. No changes will be made in quantities and no additional compensation will be allowed for this work.
- Cement stabilized backfill between boxes is considered part of the box culvert for payment.
- All curb concrete and reinforcing is considered part of the box culvert for payment.
- Any additional concrete and reinforcing required for the closures will be considered subsidiary to the box culvert for payment.
- 1'-0" typical. 2'-3" when the Box Culvert Rail Mounting Details (RAC) standard sheet is referred to elsewhere in the plans.
- For multiple unit placement with overlay, with 1 to 2 course surface treatment, or with the top slab as the final riding surface, provide wall closure as shown in Detail "A".
- This dimension may be increased with approval of the Engineer to allow the precast boxes to be tunneled or jacked in accordance with Item 476, "Jacking, Boring, or Tunneling Pipe or Box." No payment will be made for any additional material in the gap between adjacent boxes.

MATERIAL NOTES:
Provide Grade 60 reinforcing steel.
Provide ASTM A1064 welded wire reinforcement.
Provide Class C concrete (f'c = 3,600 psi) for the closures.
Provide cement stabilized backfill meeting the requirements of Item 400, "Excavation and Backfill for Structures."
Any additional concrete required for the closures will be considered subsidiary to the box culvert.

GENERAL NOTES:
Designed according to AASHTO LRFD Bridge Design Specifications.
Refer to the Single Box Culverts Precast (SCP) standard sheets for details and notes not shown.
Chamfer the bottom edge of the top slab closure 3 inches at culvert closure ends.

Cover dimensions are clear dimensions, unless noted otherwise.
Reinforcing bars dimensions are out-to-out of bars.

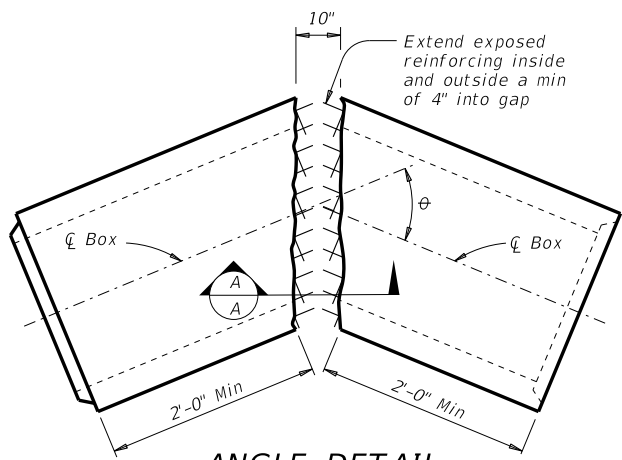

ANGLE DETAIL

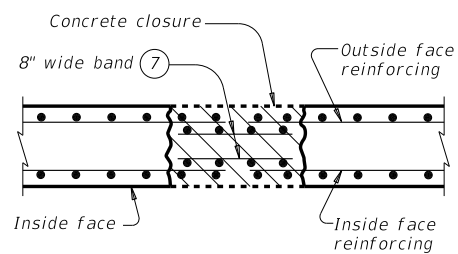

SECTION A-A

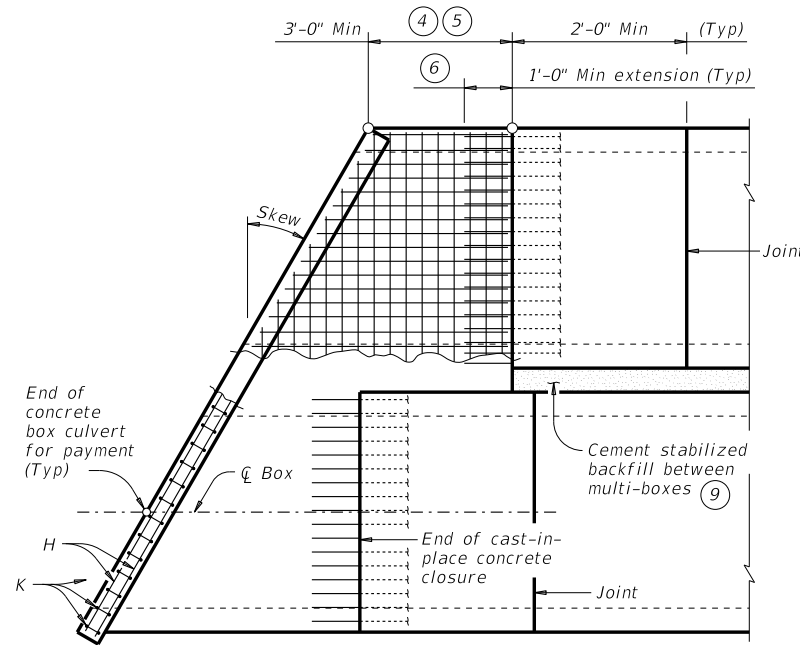

PLAN OF SKEWED ENDS

(Showing multi-box placement.)

HL93 LOADING

		Bridge Division Standard	
BOX CULVERTS PRECAST MISCELLANEOUS DETAILS			
SCP-MD			
FILE: CD-SCP-MD-20.dgn	DN: GAF	CK: LMW	DW: BWH/TxDOT
©TxDOT February 2020	CONT	SECT	JOB
REVISIONS			HIGHWAY
	DIST	COUNTY	SHEET NO.

DATE: FILE: