

DISCLAIMER: This standard is governed by the "Texas Engineering Practice Act." No warranty of any kind is made by TxDOT for any purpose whatsoever. TxDOT assumes no responsibility for the conversion to other formats or for incorrect results or damages resulting from its use.

DATE: FILE:

TABLE OF DIMENSIONS AND REINFORCING STEEL
(Wings for One Structure End)

Maximum Wingwall Height Hw (9)	Dimensions				Variable Reinforcing				Estimated Quantities per ft of wing length (Two-Wings) (3)	
	W	X	Y	Z	Bars J1		Bars J2		Reinf (Lb/Ft)	Conc (CY/Ft)
2'-6"	2'-5"	1'-0"	9"	7"	#4	1'-0"	#4	1'-0"	33.73	0.248
3'-0"	2'-5"	1'-0"	9"	7"	#4	1'-0"	#4	1'-0"	37.07	0.261
3'-6"	2'-5"	1'-0"	9"	7"	#4	1'-0"	#4	1'-0"	37.74	0.273
4'-0"	2'-5"	1'-0"	9"	7"	#4	1'-0"	#4	1'-0"	38.41	0.285
4'-6"	3'-2"	1'-6"	1'-0"	7"	#4	1'-0"	#4	1'-0"	41.75	0.330
5'-0"	3'-2"	1'-6"	1'-0"	7"	#4	1'-0"	#4	1'-0"	45.09	0.343
5'-6"	3'-2"	1'-6"	1'-0"	7"	#4	1'-0"	#4	1'-0"	45.75	0.355
6'-0"	3'-2"	1'-6"	1'-0"	7"	#4	1'-0"	#4	1'-0"	46.42	0.367
7'-0"	3'-8"	1'-9"	1'-3"	7"	#4	1'-0"	#4	1'-0"	52.77	0.414
8'-0"	4'-2"	2'-0"	1'-6"	8"	#5	1'-0"	#4	1'-0"	60.19	0.486
9'-0"	4'-8"	2'-3"	1'-9"	8"	#4	6"	#4	6"	81.49	0.535
10'-0"	5'-2"	2'-6"	2'-0"	8"	#5	6"	#4	6"	97.25	0.584
11'-0"	5'-8"	2'-9"	2'-3"	8"	#6	6"	#5	6"	133.65	0.634
12'-0"	6'-2"	3'-0"	2'-6"	9"	#7	6"	#5	6"	162.29	0.721

TABLE OF WINGWALL REINFORCING (Two-Wings)

Bar	Size	No.	Spa
D	#5	~	1'-0"
E	#4	~	1'-0"
F	#4	~	1'-0"
G	#6	4	~
M	#4	4	~
P	#4	~	1'-0"
R	#5	6	~
V	#4	~	1'-0"

TABLE OF ESTIMATED CULVERT TOEWALL QUANTITIES

Bar	Size	No.	Spa
L	#4	~	1'-6"
Q	#4	1	~
Reinf (Lb/Ft)	2.45		
Conc (CY/Ft)	0.037		

TABLE OF ESTIMATED ANCHOR TOEWALL QUANTITIES

Bar	Size	No.	Spa
K	#4	~	1'-0"
N	#5	6	~
OL	#4	6	~
Reinf (Lb/Ft)	9.82		
Conc (CY/Ft)	0.074		

- Extend Bars P 3'-0" Min into bottom slab of box culvert.
- Adjust to fit as necessary to maintain 1 #2" clear cover and 4" Min between bars.
- Quantities shown are based on an average wing height for two wings (one structure end). To determine total quantities for two wings multiply the tabulated values by Lw.
- Recommended values of slope are: 3:1, 4:1, and 6:1. Provide 3:1 or flatter slope.
- When shown elsewhere on the plans, construct 5" deep concrete riprap. Payment for riprap is as required by Item 432, "Riprap." Unless otherwise shown on the plans or directed by the Engineer, extend construction joints or grooved joints, oriented in the direction of flow, across the full distance of the riprap, at intervals of approximately 20'. When such riprap is provided, the culvert toewall shown in SECTION B-B is not required.
- At Contractor's option, end the culvert toewall flush with wingwall toewall. Adjust reinforcing as needed.
- 3" Min to 5'-0" Max. Estimated curb heights are shown elsewhere in the plans. For structures without railing and curbs taller than 1'-0", refer to Extended Curb Details (ECD) standard sheet.
- For vehicle safety, reduce curbs height, if necessary, to provide a maximum 3" projection above finished grade. No changes will be made in quantities and no additional compensation will be allowed for this work.
- See Table of Maximum Wing Heights for various slopes. Height is limited based on a 33'-6" maximum safety pipe runner length.

TABLE OF MAXIMUM WING HEIGHTS (9)

Side Slope	Hw Max
3:1	11'-5"
4:1	8'-10"
6:1	6'-1"

WING DIMENSION CALCULATIONS:

$$Hw = H + T + C - 0.250' \quad (9)$$

$$Lw = (Hw - 0.333') (SL)$$

For cast-in-place culverts:
 $Ltw = (N) (S) + (N + 1) (U)$
 For precast culverts:
 $Ltw = (N) (2U + S) + (N - 1) (0.500')$

$$Lc = (Ltw) - (2U)$$

$$Atw = Lc$$

$$\text{Total Wingwall Area (two wings ~ SF)} = (Hw + 0.333') (Lw)$$

Hw = Height of wingwall (feet)
 SL:1 = Side slope ratio (horizontal : 1 vertical)
 Lw = Length of wingwall (feet)
 Ltw = Culvert toewall length (feet)
 Lc = Culvert curb between wings (feet)
 Atw = Anchor toewall length (feet)
 N = Number of culvert spans

See applicable box culvert standard for H, S, T, and U values. See Table of Maximum Wall Heights for limits on Hw.

MATERIAL NOTES:

- Provide Grade 60 reinforcing steel.
- Provide galvanized reinforcing steel if required elsewhere in the plans.
- Synthetic fibers listed on the "Fibers for Concrete" Material Producer List (MPL) may be used in lieu of steel reinforcing in riprap concrete unless noted otherwise.
- Provide Class "C" concrete (f'c = 3,600 psi).
- Adjust reinforcing as necessary to provide a minimum clear cover of 1 1/2".
- Provide pipe runners and anchor pipes meeting the requirements of ASTM A53 (Type E or S, Gr B), ASTM A500 Gr B, or API 5LX52.
- Provide ASTM A307 bolts and nuts.
- Provide ASTM A36 steel plates.
- Galvanize all steel components, except reinforcing unless required elsewhere in the plans, after fabrication.
- Repair galvanizing damaged during transport or construction in accordance with the Item 445, "Galvanizing."
- For optional adhesive anchors, install epoxy adhesive anchorages in accordance with the manufacturer's instructions including hole size, drilling equipment and method, hole cleaning equipment and method, mixing and dispensing adhesive, and anchor insertion. Do not alter the manufacturer's mixing nozzle or dispenser. Provide anchorage rods that are clean and free of grease, oil, or any other foreign material. Demonstrate hole cleaning method to the Engineer for approval and continue the approved process for all anchorage locations. Test adhesive anchors in accordance with Item 450.3.3, "Tests." Test 3 anchors per 100 anchors installed.

GENERAL NOTES:

- Designed according to AASHTO LRFD Bridge Design Specifications.
- The safety end treatments shown herein are intended for use in those installations where out of control vehicles are likely to traverse the openings approximately perpendicular to the pipe runners.
- Pipe runners are designed for a traversing load of 1,800 pounds at yield as recommended by Research Report 280-1, "Safety Treatment of Roadside Cross-Drainage Structures", Texas Transportation Institute, March 1981.
- When structure is founded on solid rock, depth of toewalls for culverts and wingwalls may be reduced or eliminated as directed by the Engineer.
- All bolts, nuts, washers, brackets, angles, and pipe runners are considered parts of the safety end treatment for payment.
- The quantities for pipe runners, reinforcing steel, and concrete, resulting from the formulas given herein are for Contractor's information only.
- See Box Culvert Supplement (BCS) standard sheet for additional dimensions and information.

Cover dimensions are clear dimensions, unless noted otherwise. Reinforcing dimensions are out-to-out of bars.

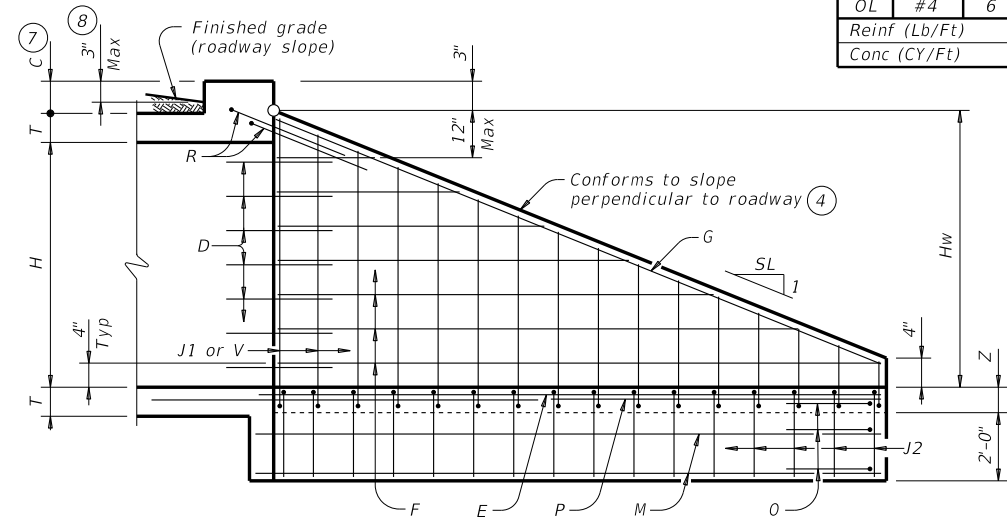

INSIDE ELEVATION OF WINGWALL

(Showing reinforcing. Culvert and culvert toewall reinforcing not shown for clarity.)

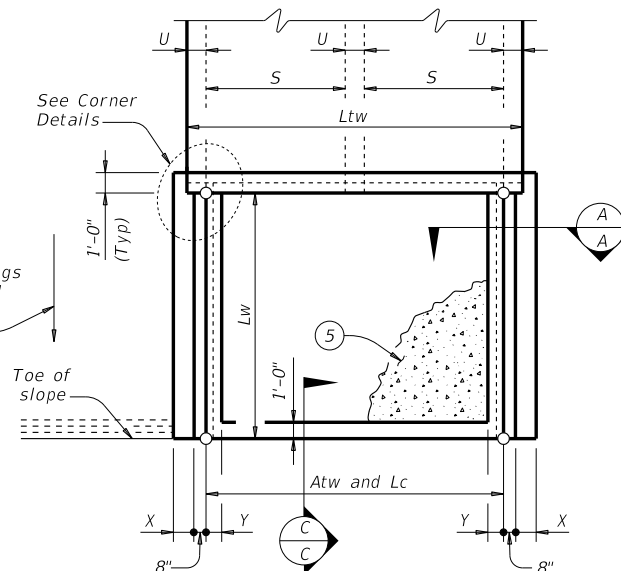

PLAN

(Showing dimensions.)

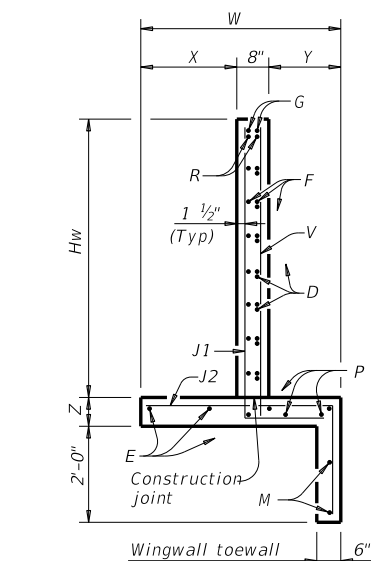

SECTION A-A

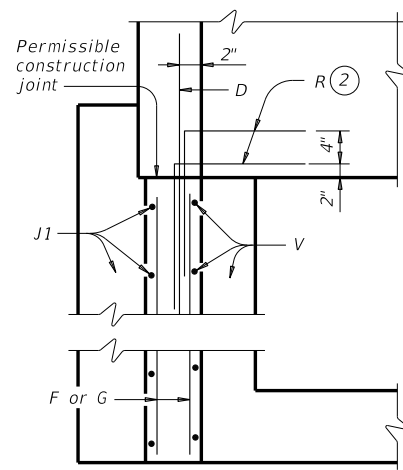

WINGWALL

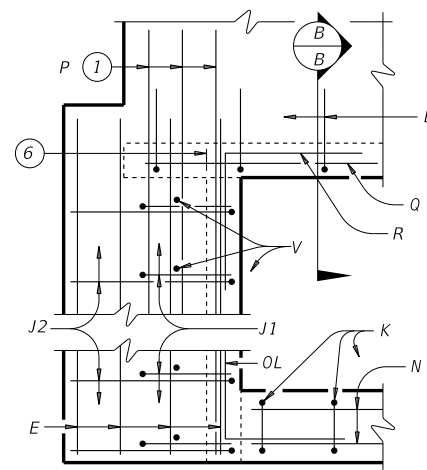

FOOTING AND TOEWALL

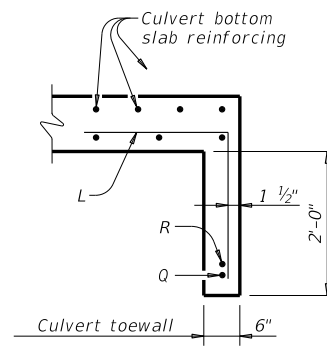

SECTION B-B (5)

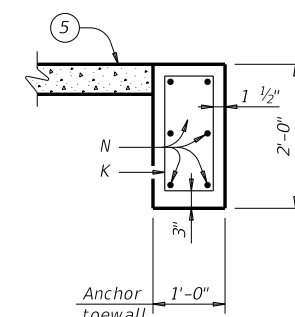

SECTION C-C

BARS J1

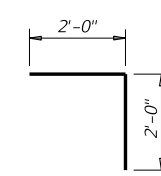

BARS V

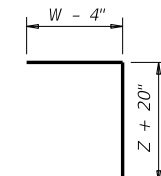

BARS L and OL

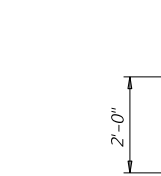

BARS J2

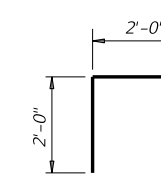

BARS R

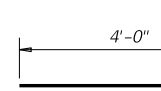

BARS D

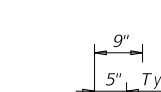

BARS K

(Length = 5'-6")

Texas Department of Transportation
 Bridge Division Standard

SAFETY END TREATMENT WITH STRAIGHT WINGS FOR 0° SKEW BOX CULVERTS TYPE I ~ CROSS DRAINAGE SETB-SW-0

FILE: CD-SETB-SW-0.dgn	DN: GAF	CK: CAT	DW: TxDOT	CK: TxDOT
©TxDOT February 2020	CONT	SECT	JOB	HIGHWAY
REVISIONS				
	DIST	COUNTY		SHEET NO.

DISCLAIMER: This standard is governed by the "Texas Engineering Practice Act." No warranty of any kind is made by TxDOT for any purpose whatsoever. TxDOT assumes no responsibility for the conversion of this standard to other formats or for incorrect results or damages resulting from its use.

DATE: FILE:

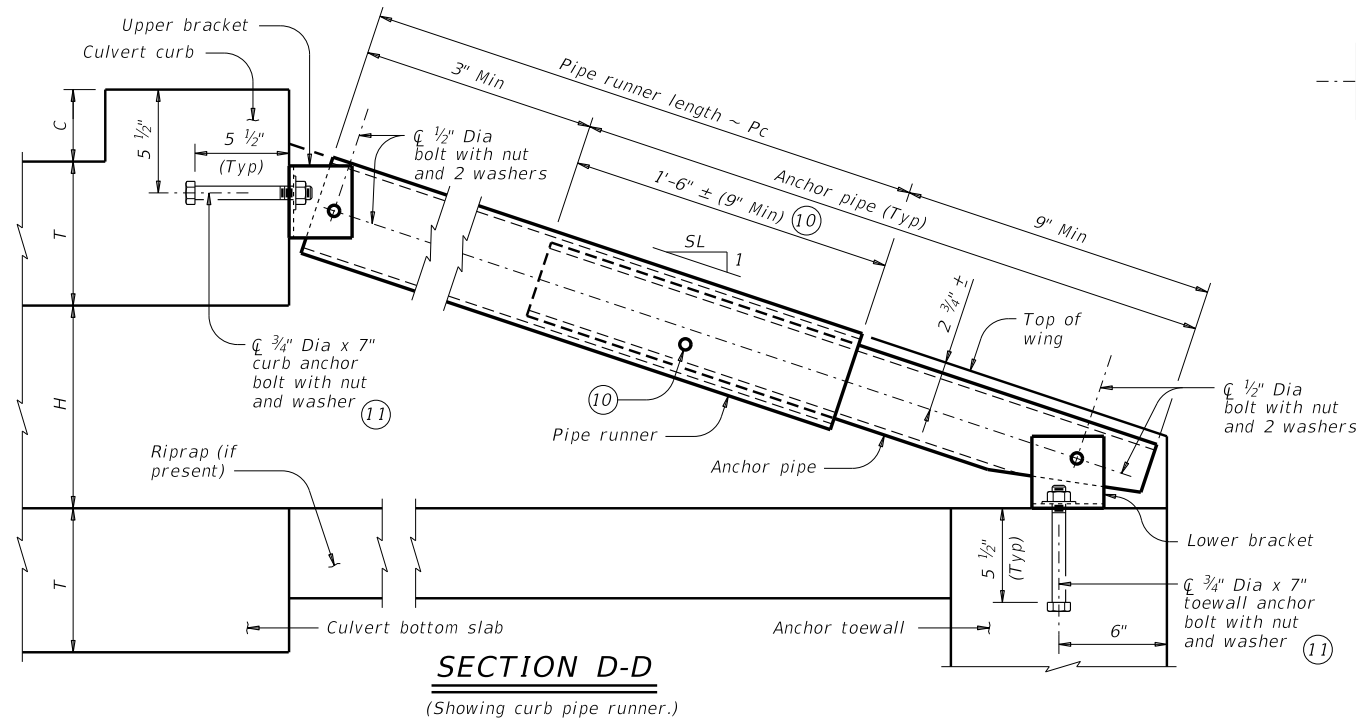

ANCHOR PIPE DETAILS

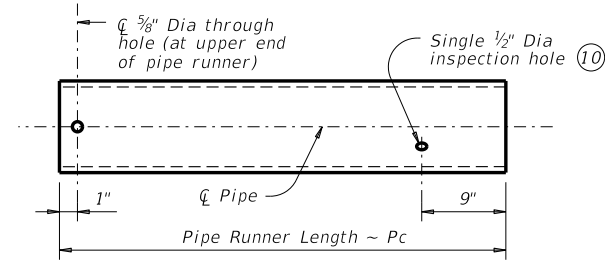
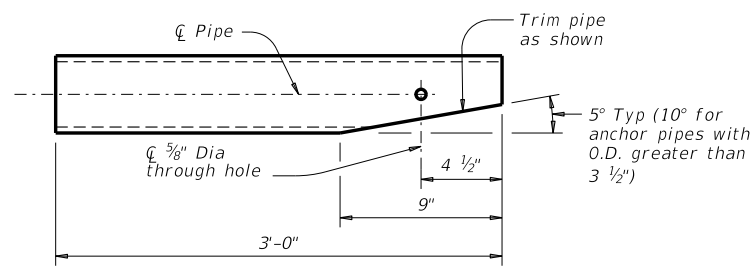

PIPE RUNNER DETAILS

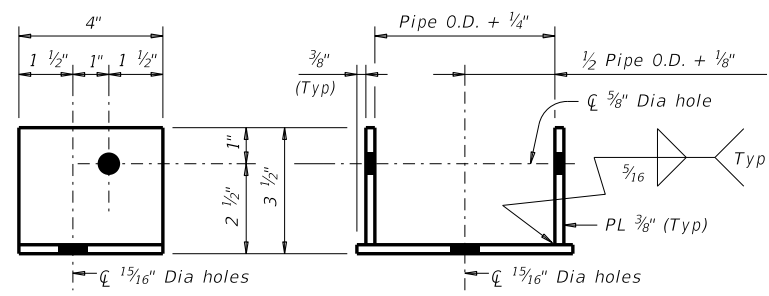

Note: Upper and lower brackets match the required pipe diameters as shown in the table.

UPPER AND LOWER BRACKET DETAILS

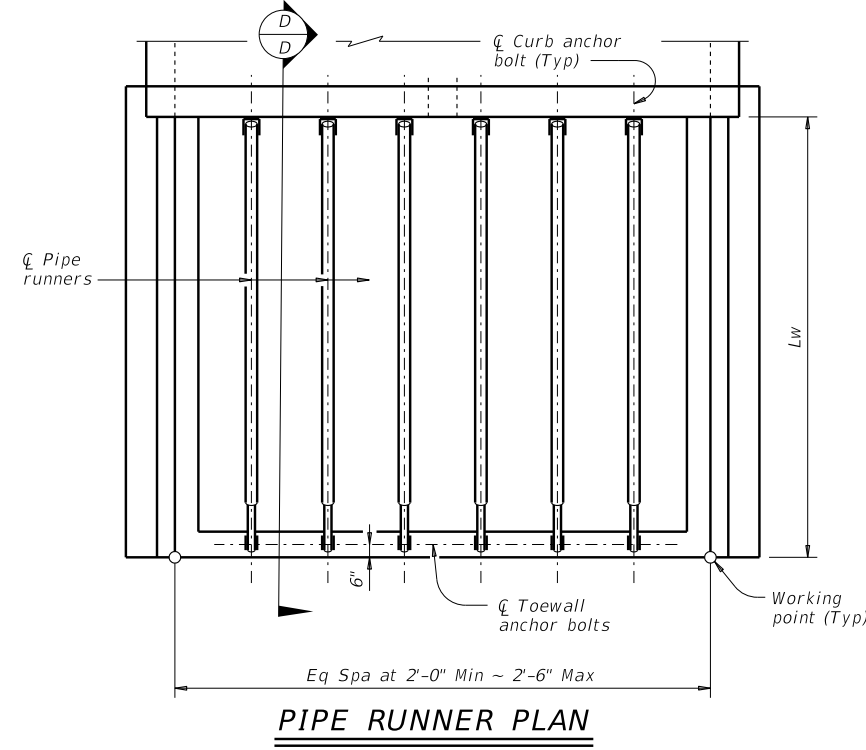

MAXIMUM PIPE RUNNER LENGTHS AND REQUIRED PIPE RUNNER AND ANCHOR PIPE SIZES

Maximum Pipe Runner Length (Pc)	Required Pipe Runner Size			Required Anchor Pipe Size		
	Pipe Size	Pipe O.D.	Pipe I.D.	Pipe Size	Pipe O.D.	Pipe I.D.
9'-4"	3" STD	3.500"	3.068"	2" STD	2.375"	2.067"
19'-0"	4" STD	4.500"	4.026"	3" STD	3.500"	3.068"
33'-6"	5" STD	5.563"	5.047"	4" STD	4.500"	4.026"

- (10) After installation of pipe runner, use the 1/2" inspection hole to ensure that the lap of the anchor pipe with the pipe runner is adequate.
- (11) At Contractor's option, an adhesive anchor may be used. Provide 3/4" Dia adhesive anchors that meet the requirements of ASTM A307. Gr A fully threaded rods. Embed threaded rods into curb, wingwalls, and toewall using a Type III, Class C, D, E, or F anchor adhesive. Minimum embedment depth is 5 1/2". Provide anchor adhesive able to achieve a basic bond strength in tension, Nba, of 20 kips. Submit signed and sealed calculations or the manufacturer's published literature showing the proposed anchor adhesive's ability to develop this load to the Engineer for approval prior to use.

PIPE RUNNER DIMENSION CALCULATIONS:
 $Pc = (Lw)(K) - (1.688)$

Pc = Pipe runner length (feet)
 K = Constant values for use in formulas
 Slope SL:1 K
 3:1 ~ 1.054
 4:1 ~ 1.031
 6:1 ~ 1.014



SAFETY END TREATMENT WITH STRAIGHT WINGS FOR 0° SKEW BOX CULVERTS TYPE I ~ CROSS DRAINAGE SETB-SW-0

FILE: CD-SETB-SW-20.dgn	DN: GAF	CK: CAT	DW: TxDOT	CK: TxDOT
©TxDOT February 2020	CONT	SECT	JOB	HIGHWAY
REVISIONS				
DIST	COUNTY			SHEET NO.

