

DISCLAIMER: The use of this standard is governed by the "Texas Engineering Practice Act." No warranty of any kind is made by TxDOT for any purpose whatsoever. TxDOT assumes no responsibility for the conversion of this standard to other formats or for incorrect results or damages resulting from its use.

DATE: FILE:

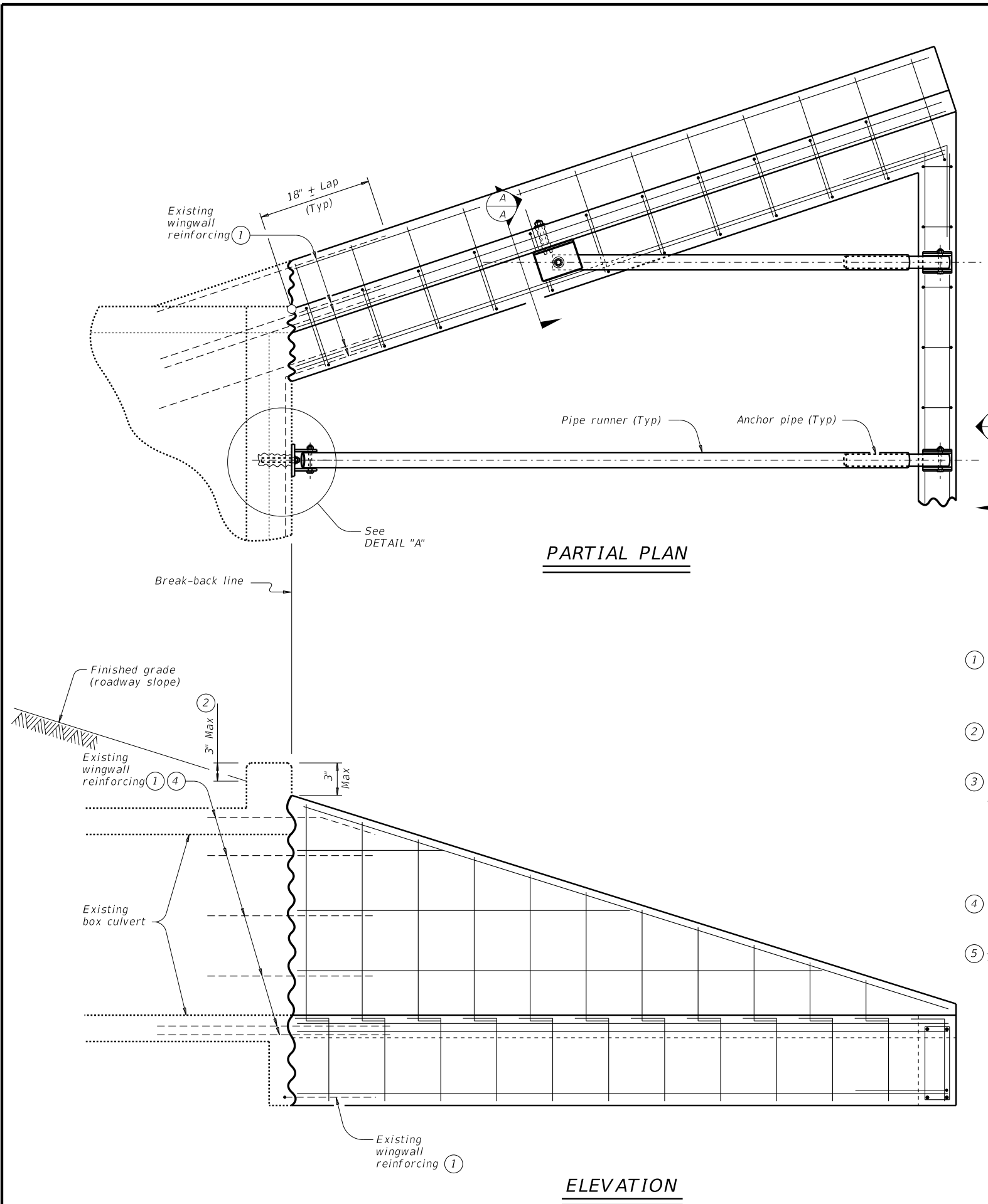

PARTIAL PLAN

ELEVATION

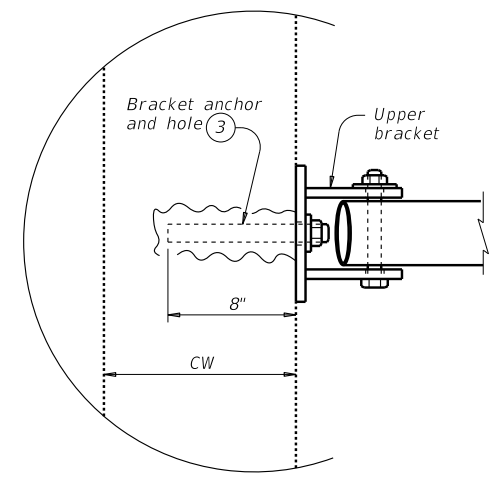

For CW greater than 8"

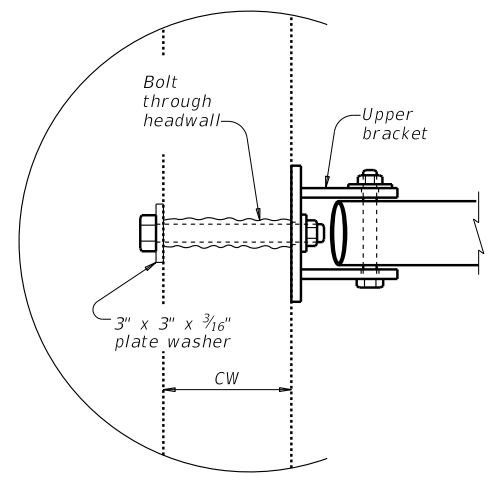

For CW 8" and less

DETAIL "A"

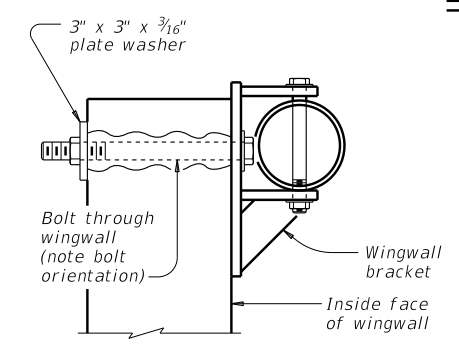

SECTION A-A

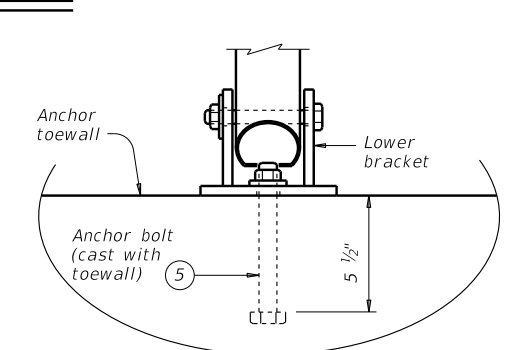

SECTION B-B

- ① Clean and straighten existing reinforcing to lap with new reinforcing as shown. The Engineer may require additional dowels to lap with the new reinforcing if the existing reinforcing is damaged or is not suitably located to lap with new reinforcing. These additional dowels must be #5 x 2'-0".
- ② For vehicle safety, reduce curb height, if necessary to provide a maximum 3" projection above finished grade. No quantity changes or additional compensation will be allowed for this work.
- ③ Provide 3/4" Dia adhesive anchors that meet the requirements of ASTM A307 Gr A fully threaded rod with one hex head nut and one hardened steel washer. Embed threaded rods into curb, wingwall, and toewall using a Type III, Class C, D, E, or F anchor adhesive. Minimum embedment depth is 8". Provide anchor adhesive able to achieve a basic bond strength in tension, Nba, of 20 kips. Submit signed and sealed calculations or the manufacturer's published literature showing the proposed anchor adhesive's ability to develop this load to the Engineer for approval prior to use.
- ④ If required, embed wingwall anchor dowels into existing box culvert using a Type III, Class C, D, E, or F anchor adhesive. Minimum embedment depth is 8".
- ⑤ At Contractor's option, adhesive anchors may be used. Provide 3/4" Dia adhesive anchors that meet the requirements of ASTM A307 Gr A fully threaded rods. Embed threaded rods into curb, wingwalls, and toewall using a Type III, Class C, D, E, or F anchor adhesive. Minimum embedment depth is 8". Provide anchor adhesive able to achieve a basic bond strength in tension, Nba, of 20 kips. Submit signed and sealed calculations or the manufacturer's published literature showing the proposed anchor adhesive's ability to develop this load to the Engineer for approval prior to use.

MATERIAL NOTES:

Install epoxy adhesive anchorages in accordance with the manufacturer's instructions including hole size, drilling equipment and method, hole cleaning equipment and method, mixing and dispensing epoxy, and anchor insertion. Do not alter the manufacturer's mixing nozzle or dispenser. Anchorage bars or bolts must be clean and free of grease, oil, or any other foreign material. Demonstrate hole cleaning method to the Engineer for approval and continue the approved process for all anchorage locations. Test adhesive anchors in accordance with Item 450.3.3, "Tests." Test 3 anchors per 100 anchors installed.

GENERAL NOTES:

Use these details in conjunction with the SETB standard sheets. Shorten reinforcing Bars D, M, P, and R when utilizing existing reinforcing, as shown. If required, add dowels to lap with new reinforcing, as shown. No increase or decrease to the pay quantities is permitted for these adjustments in the reinforcing steel or concrete quantities.

		Bridge Division Standard	
SAFETY END TREATMENT RETROFIT DETAILS FOR EXISTING BOX CULVERTS			
SETBR			
FILE: CD-SETBR-20.dgn	DN: GAF	CK: TxDOT	DW: TxDOT
©TxDOT February 2020	CONT	SECT	JOB
REVISIONS		HIGHWAY	
DIST		COUNTY	
		SHEET NO.	