

DISCLAIMER: The use of this standard is governed by the "Texas Engineering Practice Act." No warranty of any kind is made by TxDOT for any purpose whatsoever. TxDOT assumes no responsibility for the conversion of this standard to other formats or for incorrect results or damages resulting from its use.

TABLE OF VARIABLE DIMENSIONS AND QUANTITIES FOR ONE HEADWALL (5)

Slope	Dia of Pipe (D)	Values for One Pipe					Values to be Added for Each Add'l Pipe			
		W	X	Y	L	Reinf (Lbs)	Conc (CY)	X and W	Reinf (Lbs)	Conc (CY)
3:1	24"	10' - 7 1/2"	4' - 7"	7' - 3"	10' - 3"	231	2.3	4' - 1 3/4"	65	0.9
	27"	11' - 8 1/2"	4' - 11"	8' - 0"	11' - 3 3/4"	259	2.7	4' - 6 1/4"	75	1.0
	30"	12' - 9 1/2"	5' - 3"	8' - 9"	12' - 4 1/2"	302	3.1	5' - 0"	86	1.2
	33"	13' - 10 3/4"	5' - 7"	9' - 6"	13' - 5 1/4"	328	3.5	5' - 4 3/4"	94	1.4
	36"	14' - 11 3/4"	5' - 11 1/4"	10' - 3"	14' - 6"	361	4.0	5' - 10 1/2"	108	1.6
	42"	17' - 1 3/4"	6' - 7 1/4"	11' - 9"	16' - 7 1/2"	447	5.0	6' - 8 3/4"	133	2.1
	48"	20' - 0 3/4"	7' - 3 1/4"	14' - 0"	19' - 9 1/2"	550	6.6	7' - 7 1/4"	176	2.8
	54"	22' - 3"	7' - 11 1/2"	15' - 6"	21' - 11"	636	7.9	8' - 8"	211	3.5
	60"	24' - 5"	8' - 7 1/2"	17' - 0"	24' - 0 1/2"	735	9.4	9' - 6 1/4"	246	4.1
	66"	26' - 7"	9' - 3 1/2"	18' - 6"	26' - 2"	833	10.9	10' - 1 1/4"	274	4.6
4:1	24"	13' - 0 3/4"	4' - 7"	9' - 8"	13' - 8"	305	3.1	4' - 1 3/4"	75	1.1
	27"	14' - 4 1/2"	4' - 11"	10' - 8"	15' - 1"	343	3.7	4' - 6 1/4"	87	1.3
	30"	15' - 8 1/2"	5' - 3"	11' - 8"	16' - 6"	398	4.2	5' - 0"	99	1.5
	33"	17' - 0 3/4"	5' - 7"	12' - 8"	17' - 11"	438	4.9	5' - 4 3/4"	112	1.7
	36"	18' - 4 3/4"	5' - 11 1/4"	13' - 8"	19' - 4"	485	5.5	5' - 10 1/2"	128	2.0
	42"	21' - 0 3/4"	6' - 7 1/4"	15' - 8"	22' - 1 3/4"	593	7.0	6' - 8 3/4"	158	2.6
	48"	24' - 8 3/4"	7' - 3 1/4"	18' - 8"	26' - 4 3/4"	746	9.4	7' - 7 1/4"	211	3.4
	54"	27' - 5"	7' - 11 1/2"	20' - 8"	29' - 2 3/4"	881	11.3	8' - 8"	257	4.3
	60"	30' - 1"	8' - 7 1/2"	22' - 8"	32' - 0 3/4"	1,009	13.3	9' - 6 1/4"	297	5.1
	66"	32' - 9"	9' - 3 1/2"	24' - 8"	34' - 10 1/2"	1,151	15.6	10' - 1 1/4"	340	5.8
6:1	24"	17' - 10 1/2"	4' - 7"	14' - 6"	20' - 6"	454	5.1	4' - 1 3/4"	91	1.5
	27"	19' - 8 1/2"	4' - 11"	16' - 0"	22' - 7 1/2"	523	6.0	4' - 6 1/4"	108	1.7
	30"	21' - 6 1/2"	5' - 3"	17' - 6"	24' - 9"	599	7.1	5' - 0"	124	2.0
	33"	23' - 4 3/4"	5' - 7"	19' - 0"	26' - 10 1/2"	680	8.2	5' - 4 3/4"	143	2.4
	36"	25' - 2 3/4"	5' - 11 1/4"	20' - 6"	29' - 0"	743	9.3	5' - 10 1/2"	162	2.8
	42"	28' - 10 3/4"	6' - 7 1/4"	23' - 6"	33' - 2 3/4"	926	11.9	6' - 8 3/4"	202	3.6
	48"	34' - 0 3/4"	7' - 3 1/4"	28' - 0"	39' - 7 1/4"	1,197	16.2	7' - 7 1/4"	274	4.7

- Quantities shown are for concrete pipe and will increase slightly for metal pipe installation.
- For vehicle safety, reduce curb heights, if necessary, to provide a maximum 3" projection above finished grade. No changes will be made in quantities and no additional compensation will be allowed for this work.
- Provide a 1'-0" footing as shown where required to maintain 4" minimum cover for pipes.
- Dimensions shown are usual and maximum.
- Quantities shown are for one structure end. (One headwall)
- Min Length = $6" + 3" \times \left(\frac{12 \times H - 7}{12 \times L} \right)$
Max Length = $12 \times H - 3" \times \left(\frac{12 \times H - 7}{12 \times L} \right) - 1"$
- Lengths of wings based on SL:1 slope along this line.

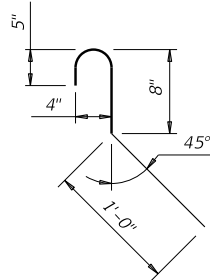

BARS CL
(Length = 2'-5")

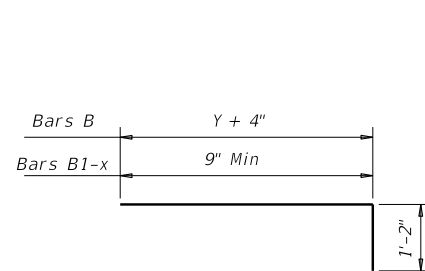

BARS B and B1-x

BARS VL and VS

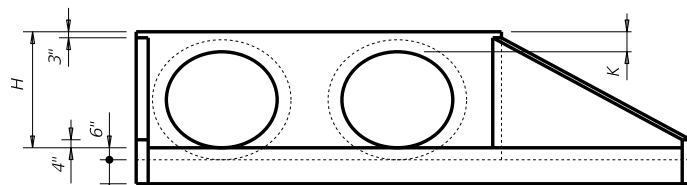

ELEVATION

(Showing dimensions.)

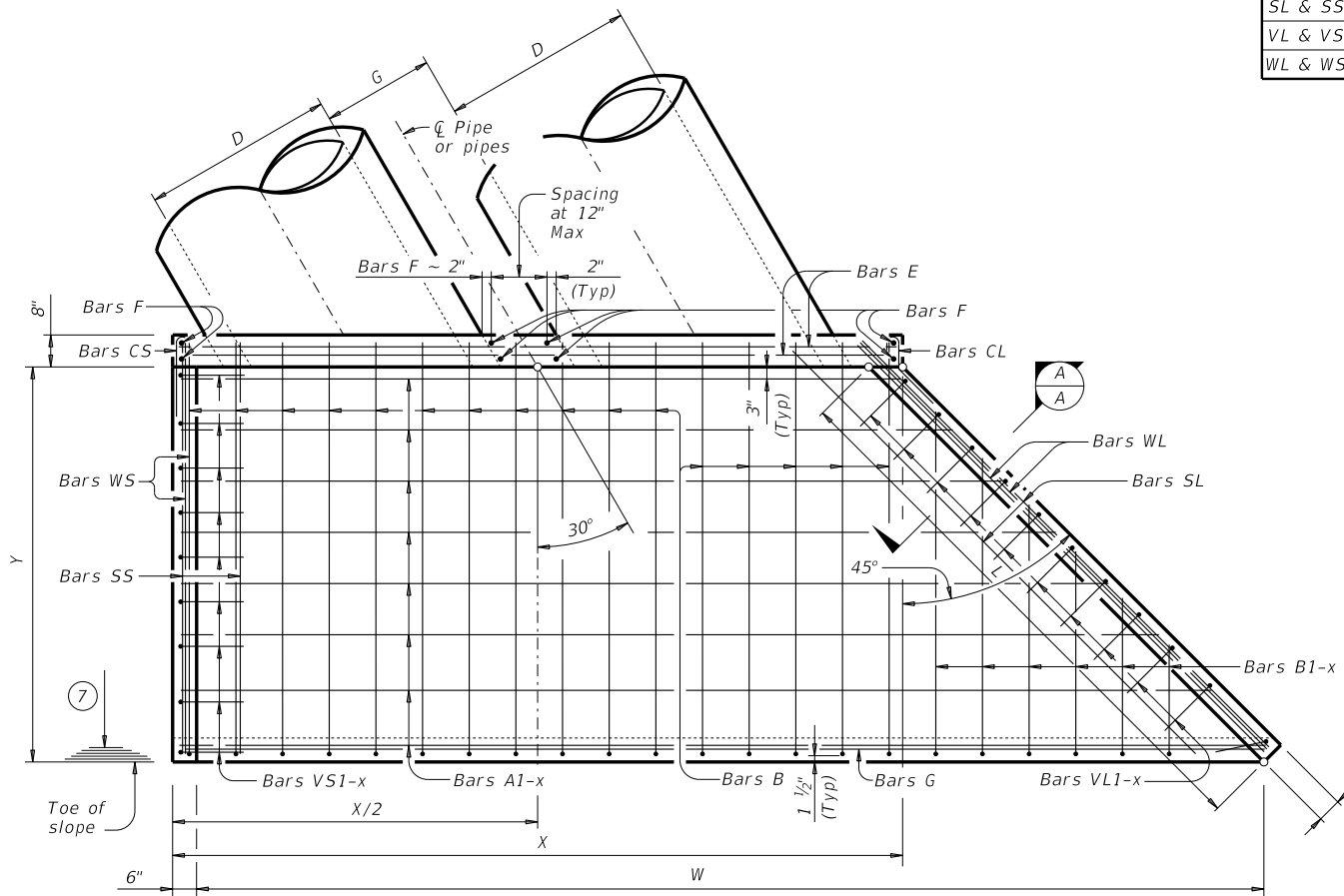

PLAN

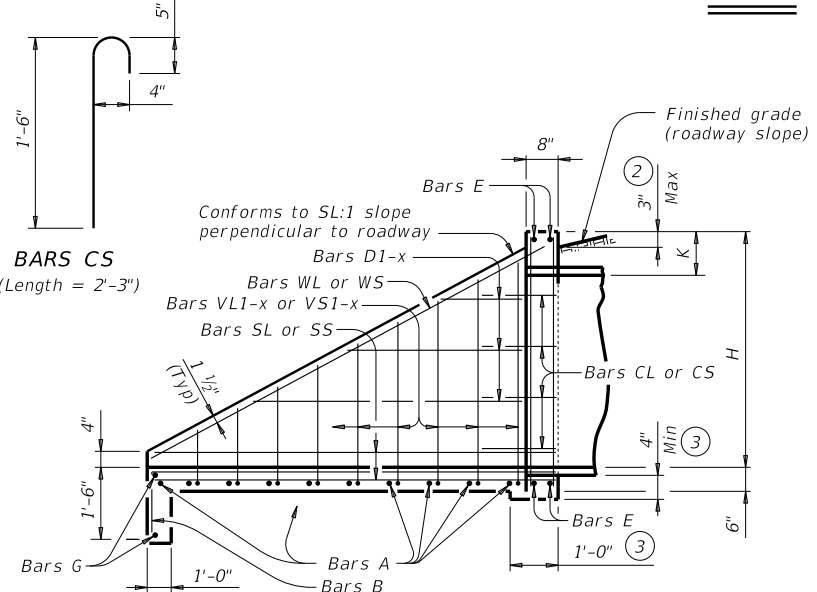

TYPICAL WING ELEVATION

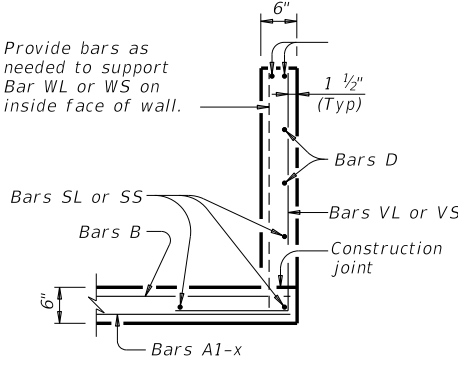

SECTION A-A

TABLE OF REINFORCING STEEL (5)

Bar	Size	Spa	No.
A	#4	1' - 0"	~
B	#3	1' - 6"	~
CL & CS	#4	1' - 0"	~
D	#3	1' - 0"	~
E	#5	~	4
F	#5	~	~
G	#3	~	2
SL & SS	#4	~	6
VL & VS	#4	1' - 0"	~
WL & WS	#5	~	4

TABLE OF CONSTANT DIMENSIONS

Dia of Pipe (D)	G	K (4)	H
24"	1' - 7"	1' - 0"	3' - 0"
27"	1' - 8"	1' - 0"	3' - 3"
30"	1' - 10"	1' - 0"	3' - 6"
33"	1' - 11"	1' - 0"	3' - 9"
36"	2' - 1"	1' - 0"	4' - 0"
42"	2' - 4"	1' - 0"	4' - 6"
48"	2' - 7"	1' - 3"	5' - 3"
54"	3' - 0"	1' - 3"	5' - 9"
60"	3' - 3"	1' - 3"	6' - 3"
66"	3' - 3"	1' - 3"	6' - 9"
72"	3' - 4"	1' - 3"	7' - 3"

MATERIAL NOTES:
 Provide Grade 60 reinforcing steel.
 Provide galvanized reinforcing steel, if required elsewhere in the plans.
 Adjust reinforcing bars, as necessary, to provide a minimum clear cover of 1 1/2".
 Provide Class C concrete (f'c = 3,600 psi).
 Provide pipe runners that meet the requirements of ASTM A53 (Type E or S, Gr B), ASTM A500 Gr B, or API 5LX52.
 Provide ASTM A307 bolts and nuts.
 Provide ASTM A36 steel plates.
 Galvanize all steel components, except reinforcing unless required elsewhere in the plans, after lubrication. Repair galvanizing damaged during transport or construction in accordance with the specifications.
 For optional adhesive anchors, install adhesive anchorages in accordance with the manufacturer's instructions including hole size, drilling equipment and method, hole cleaning method to the Engineer for approval and continue the approved process for all anchor locations. Test adhesive anchors in accordance with Item 450.3.3, "Tests." Test 3 anchors per 100 anchors installed.

GENERAL NOTES:
 Designed according to AASHTO LRFD Bridge Design Specifications.
 Safety end treatments (SET) shown herein are intended for use in those installations where out of control vehicles are likely to traverse the openings approximately perpendicular to the pipe runners.
 The safety pipe runners are designed for a traversing load of 1,800 pounds at yield as recommended by Research Report 280-1, "Safety Treatment of Roadside Cross-Drainage Structures", Texas Transportation Institute, March 1981.
 All bolts, nuts, washers, brackets, angles and pipe runners are considered parts of the safety end treatment for payment.

Cover dimensions are clear dimensions, unless noted otherwise. Reinforcing dimensions are out-to-out of bars.

Texas Department of Transportation Bridge Division Standard

SAFETY END TREATMENT WITH FLARED WINGS FOR 30° SKEW PIPE CULVERTS TYPE I ~ CROSS DRAINAGE

SETP-FW-30

FILE: CD-SETP-FW30-20.dgn	DN: GAF	CK: CAT	DW: BWH	CK: GAF
©TxDOT February 2020	CONT	SECT	JOB	HIGHWAY
REVISIONS	DIST	COUNTY	SHEET NO.	

DATE: FILE:

DISCLAIMER: The use of this standard is governed by the "Texas Engineering Practice Act." No warranty of any kind is made by TxDOT for any purpose whatsoever. TxDOT assumes no responsibility for the conversion of this standard to other formats or for incorrect results or damages resulting from its use.

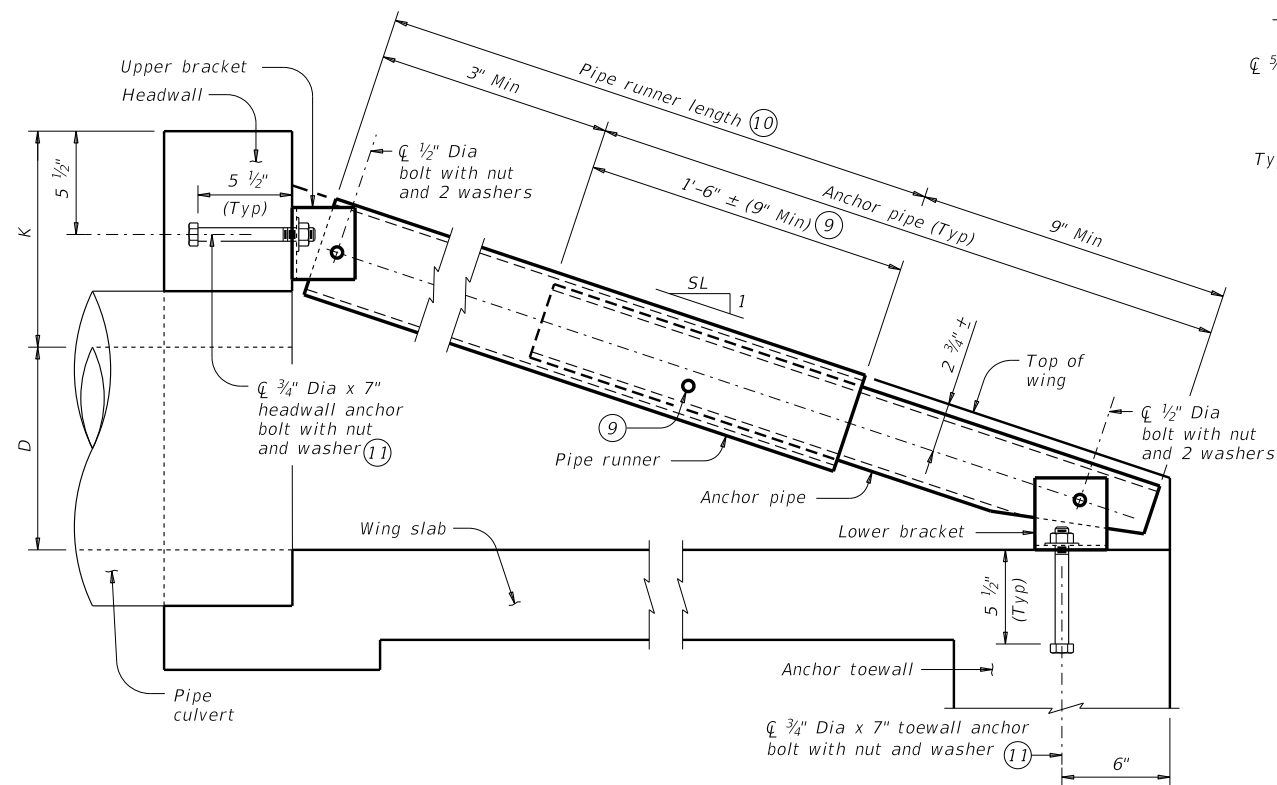

SECTION B-B

(Showing headwall pipe runner. Except for upper bracket, wingwall pipe runners are similar.)

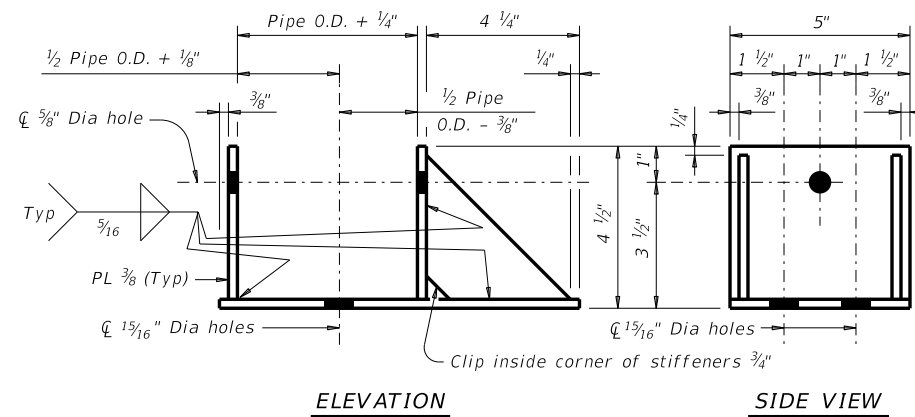

ELEVATION

SIDE VIEW

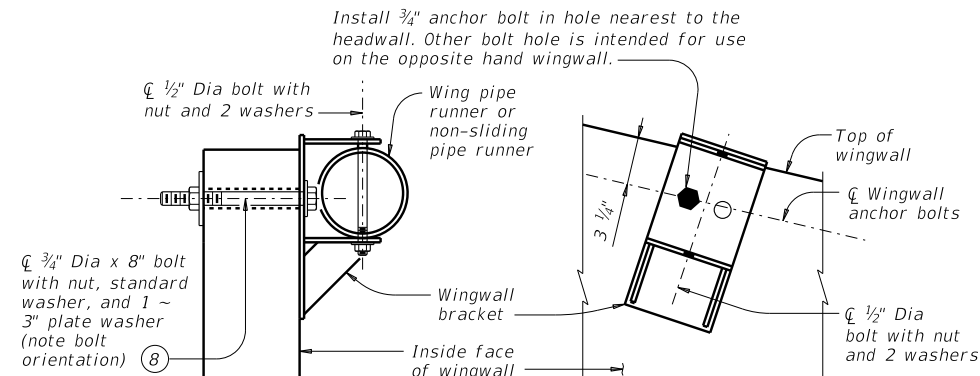

SECTION C-C

(Showing installed bracket.)

ELEVATION

(Showing installed bracket normal to wall. Pipe not shown for clarity.)

NOTE: Match the wingwall bracket to the upper bracket size.

WINGWALL BRACKET DETAILS

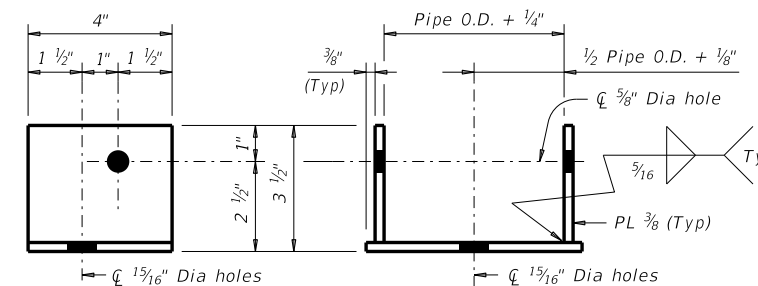

SIDE VIEW

ELEVATION

NOTE: Match upper and lower brackets, except for the brackets used with non-sliding pipe runners, with the required pipe diameters as shown in the table.

UPPER AND LOWER BRACKET DETAILS

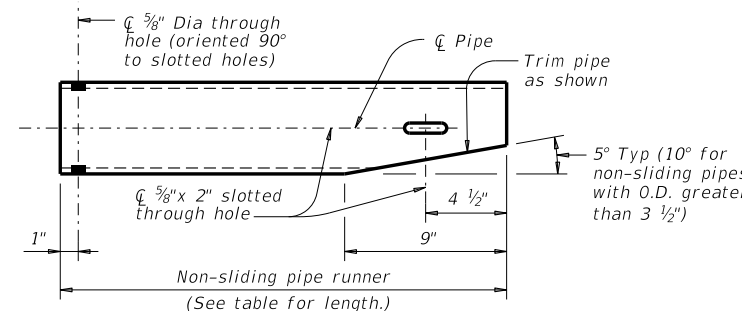

Note: Pipe size is the same as required for headwall pipe runner. Adjust the corresponding lower bracket accordingly.

NON-SLIDING PIPE RUNNER DETAILS

- 8 At Contractor's option, 7/8" diameter hole may be formed or cored drilled. Percussion drilling is not permitted. Adjust placement of reinforcing steel as necessary to avoid bolt holes.
- 9 After installation of the pipe runner, use the 1/2" inspection hole to ensure that the lap of the anchor pipe with the pipe runner is adequate.
- 10 Non-sliding pipe runners are used for those installations that would require pipe runner lengths of 1'-9" or less. The non-sliding pipe runner, when required, replaces the outermost pipe runner and anchor pipe. See table on Sheet 3 of 3 to determine if the non-sliding pipe runner is required.
- 11 At Contractor's option, an adhesive anchor may be used. Provide adhesive anchors that are 3/4" Dia ASTM A307 Grade A fully threaded rods. Embed threaded rods into curb, wingwalls, and/or toewall using a Type III, Class C, D, E, or F anchor adhesive. Minimum embedment depth is 5 1/2". Anchor adhesive chosen must be able to achieve a basic bond strength in tension, Nba, of 20 kips. Submit signed and sealed calculations or the manufacturer's published literature showing the proposed anchor adhesive's ability to develop this load to the Engineer for approval prior to use.

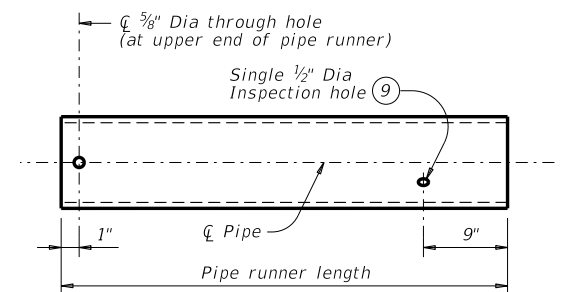

PIPE RUNNER DETAILS

Note: Use pipe diameter required for headwall pipe runner for wingwall pipe runner.

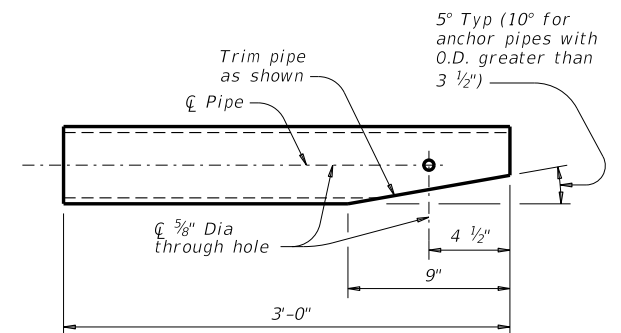

ANCHOR PIPE DETAILS

SHEET 2 OF 3

		Bridge Division Standard	
SAFETY END TREATMENT WITH FLARED WINGS FOR 30° SKEW PIPE CULVERTS TYPE I ~ CROSS DRAINAGE			
SETP-FW-30			
FILE: CD-SETP-FW30-20.dgn	DN: GAF	CK: CAT	DW: TxDOT
©TxDOT February 2020	CONT	SECT	JOB
REVISIONS			HIGHWAY
	DIST	COUNTY	SHEET NO.

DATE: FILE:

DISCLAIMER: The use of this standard is governed by the "Texas Engineering Practice Act." No warranty of any kind is made by TxDOT for any purpose whatsoever. TxDOT assumes no responsibility for the conversion of this standard to other formats or for incorrect results or damages resulting from its use.

DATE: FILE:

Pipe Culvert Dia	No. of Pipe Culverts	No. of L2 Spaces	L2 Overall Dimension	No. of Headwall Pipes
24"	1	1	2' - 4 1/2"	1
	2	3	6' - 6 1/4"	3
	3	5	10' - 8"	5
	4	6	14' - 9 3/4"	6
	5	8	18' - 11 1/2"	8
	6	10	23' - 1 1/4"	10
27"	1	1	2' - 5 1/2"	1
	2	3	6' - 11 3/4"	3
	3	5	11' - 6"	5
	4	7	16' - 0 1/4"	7
	5	9	20' - 6 1/2"	9
	6	10	25' - 0 3/4"	10
30"	1	1	2' - 6 1/2"	1
	2	3	7' - 6 1/2"	3
	3	5	12' - 6 1/2"	5
	4	7	17' - 6 1/2"	7
	5	9	22' - 6 1/2"	9
	6	11	27' - 6 1/2"	11
33"	1	2	3' - 10 1/2"	2
	2	4	9' - 3 1/4"	4
	3	6	14' - 8"	6
	4	9	20' - 0 3/4"	9
	5	11	25' - 5 1/2"	11
	6	13	30' - 10 1/4"	13
36"	1	2	3' - 11 3/4"	2
	2	4	9' - 10 1/4"	4
	3	7	15' - 8 3/4"	7
	4	9	21' - 7 1/4"	9
	5	11	27' - 5 3/4"	11
	6	14	33' - 4 1/4"	14
42"	1	2	4' - 10 3/4"	2
	2	5	11' - 7 1/2"	5
	3	8	18' - 4 1/4"	8
	4	11	25' - 1"	11
	5	13	31' - 9 3/4"	13
	6	16	38' - 6 1/2"	16
48"	1	2	4' - 9 3/4"	2
	2	5	12' - 5"	5
	3	8	20' - 0 1/4"	8
	4	12	27' - 7 1/2"	12
	5	15	35' - 2 3/4"	15
	6	18	42' - 10"	18
54"	1	3	6' - 3"	3
	2	6	14' - 11"	6
	3	10	23' - 7"	10
	4	13	32' - 3"	13
	5	17	40' - 11"	17
	6	20	49' - 7"	20
60"	1	3	6' - 11"	3
	2	7	16' - 5 1/4"	7
	3	11	25' - 11 1/2"	11
	4	15	35' - 5 3/4"	15
	5	19	45' - 0"	19
	6	22	54' - 6 1/4"	22
66"	1	3	7' - 4"	3
	2	7	17' - 5 1/4"	7
	3	11	27' - 6 1/2"	11
	4	16	37' - 7 3/4"	16
	5	20	47' - 9"	20
	6	24	57' - 10 1/4"	24
72"	1	3	7' - 3 1/4"	3
	2	8	18' - 0 1/2"	8
	3	12	28' - 9 3/4"	12
	4	16	39' - 7"	16
	5	21	50' - 4 1/4"	21
	6	25	61' - 1 1/2"	25

Side Slope	Pipe Culvert Dia	L1	P1	No. of Spaces in L3	L3 Overall Dimension	P2	No. of Spaces in L4	L4 Overall Dimension	Headwall Pipe Runner Length	No. of Wing Pipes	Longest Wingwall Pipe Runner Length	Shortest Wingwall Pipe Runner Length	Non-Sliding Pipe Length	Pipe Runner Size	Total Length of Wingwall Pipe Runners
3:1	24"	1' - 0"	2' - 0"	3	6' - 3"	2' - 7 1/2"	2	5' - 10 3/4"	5' - 11 1/2"	3	4' - 5 1/4"	2' - 3"	1' - 6 1/2"	3" STD	8' - 2 3/4"
	27"	1' - 3"	2' - 0"	3	7' - 3"	2' - 7 1/2"	2	6' - 10"	6' - 9"	3	5' - 1 3/4"	2' - 7"	1' - 6 1/2"	3" STD	9' - 3 1/4"
	30"	1' - 6"	3' - 0"	3	7' - 3"	4' - 0 1/2"	2	6' - 10"	7' - 6 1/2"	3	6' - 2 1/4"	3' - 7 3/4"	2' - 7 1/4"	3" STD	12' - 5 1/4"
	33"	0' - 6"	2' - 6"	3	7' - 6"	3' - 4"	2	7' - 0 3/4"	8' - 4"	3	5' - 10"	3' - 2 1/2"	2' - 0 3/4"	3" STD	11' - 1 1/4"
	36"	0' - 9"	2' - 0"	4	9' - 0"	2' - 7 1/2"	3	9' - 6 1/2"	9' - 1 1/2"	4	7' - 2"	2' - 5"	1' - 6 1/2"	4" STD	15' - 11"
	42"	0' - 6"	2' - 3"	4	10' - 0"	2' - 11 3/4"	3	10' - 7 1/4"	10' - 8 1/4"	4	8' - 2 1/2"	2' - 11 1/4"	1' - 9 3/4"	4" STD	18' - 6 1/2"
	48"	1' - 3"	2' - 9"	5	12' - 6"	3' - 8 1/2"	4	14' - 1 3/4"	13' - 0 3/4"	5	11' - 4 1/2"	3' - 5 3/4"	2' - 4"	4" STD	32' - 0 1/2"
	54"	0' - 6"	2' - 0"	6	14' - 0"	2' - 7 1/2"	5	16' - 6"	14' - 7 3/4"	6	12' - 4"	2' - 6"	1' - 6 1/2"	4" STD	38' - 7 1/2"
	60"	0' - 6"	2' - 6"	6	15' - 0"	3' - 4"	5	17' - 8"	16' - 2 3/4"	6	13' - 9"	3' - 2 1/2"	2' - 0 3/4"	4" STD	44' - 5 1/2"
	66"	0' - 9"	2' - 0"	7	17' - 3"	2' - 7 1/2"	6	20' - 11"	17' - 9 3/4"	7	15' - 7 1/2"	2' - 7 3/4"	1' - 6 1/2"	4" STD	56' - 4 1/4"
4:1	24"	1' - 6"	2' - 0"	8	19' - 6"	2' - 7 1/2"	7	24' - 1 1/2"	19' - 4 3/4"	8	18' - 0 1/4"	2' - 7 1/4"	1' - 6 1/2"	5" STD	73' - 8 3/4"
	27"	1' - 0"	2' - 0"	4	8' - 8"	2' - 7 1/2"	3	9' - 2 1/4"	8' - 3 1/4"	4	6' - 8 1/2"	2' - 2 3/4"	1' - 6"	3" STD	14' - 11"
	30"	1' - 3"	2' - 0"	4	9' - 11"	2' - 7 1/2"	3	10' - 6 1/4"	9' - 3 3/4"	4	7' - 8"	2' - 6 3/4"	1' - 6"	4" STD	16' - 10 1/4"
	33"	1' - 6"	2' - 0"	5	11' - 2"	2' - 7 1/2"	4	12' - 7 1/2"	10' - 4"	5	9' - 2 1/2"	2' - 3 1/2"	1' - 6"	4" STD	24' - 6"
	36"	0' - 6"	2' - 0"	5	11' - 2"	2' - 7 1/2"	4	12' - 7 1/2"	11' - 4 1/2"	5	9' - 2 1/2"	2' - 3 1/2"	1' - 6"	4" STD	24' - 6"
	42"	0' - 6"	2' - 0"	6	14' - 2"	2' - 7 1/2"	5	16' - 8 1/4"	14' - 5 1/2"	6	12' - 2"	2' - 5 1/4"	1' - 6"	4" STD	38' - 0 1/4"
	48"	1' - 3"	2' - 6"	7	17' - 5"	3' - 4"	6	21' - 1 1/4"	17' - 6 3/4"	7	15' - 10 3/4"	3' - 1"	2' - 0 1/4"	4" STD	58' - 11 1/2"
	54"	0' - 6"	2' - 0"	8	19' - 2"	2' - 7 1/2"	7	23' - 8 1/2"	19' - 7 1/2"	8	17' - 3 1/2"	2' - 5 3/4"	1' - 6"	5" STD	70' - 8 1/2"
	60"	0' - 6"	2' - 0"	9	21' - 2"	2' - 7 1/2"	8	26' - 7 1/4"	21' - 8 1/4"	9	19' - 4 3/4"	2' - 5"	1' - 6"	5" STD	88' - 9"
	66"	0' - 9"	3' - 0"	9	22' - 5"	4' - 0 1/2"	8	28' - 2"	23' - 9"	9	21' - 7"	3' - 7 1/4"	2' - 6 1/4"	5" STD	103' - 3 1/4"
6:1	24"	1' - 6"	2' - 0"	11	26' - 2"	2' - 7 1/2"	10	33' - 7 3/4"	25' - 9 3/4"	11	24' - 6 1/4"	2' - 5 1/2"	1' - 6"	5" STD	136' - 4 3/4"
	27"	1' - 0"	3' - 0"	5	12' - 6"	4' - 0 1/2"	4	14' - 1 3/4"	13' - 0 1/4"	5	11' - 1 1/2"	3' - 6 1/4"	2' - 5 3/4"	4" STD	31' - 9 1/4"
	30"	1' - 3"	2' - 3"	6	15' - 0"	2' - 11 3/4"	5	17' - 8"	14' - 6 1/2"	6	12' - 10 3/4"	2' - 9"	1' - 8 1/2"	4" STD	40' - 10"
	33"	1' - 6"	2' - 0"	7	17' - 0"	2' - 7 1/2"	6	20' - 7 1/4"	16' - 0 3/4"	7	14' - 9"	2' - 5 1/2"	1' - 5 1/2"	4" STD	53' - 0 1/4"
	36"	0' - 6"	2' - 0"	7	17' - 6"	2' - 7 1/2"	6	21' - 2 1/2"	17' - 7"	7	15' - 2"	2' - 6"	1' - 5 1/2"	4" STD	54' - 5 1/2"
	42"	0' - 9"	2' - 0"	8	19' - 3"	2' - 7 1/2"	7	23' - 9 3/4"	19' - 1 1/4"	8	17' - 0 1/2"	2' - 4 3/4"	1' - 5 1/2"	5" STD	69' - 6"
	48"	0' - 6"	2' - 0"	9	22' - 0"	2' - 7 1/2"	8	27' - 7 3/4"	22' - 1 3/4"	9	19' - 9 1/2"	2' - 5 1/4"	1' - 5 1/2"	5" STD	90' - 4 1/2"
	54"	1' - 3"	2' - 0"	11	27' - 3"	2' - 7 1/2"	10	35' - 0 1/4"	26' - 8 1/2"	11	25' - 1"	2' - 5 3/4"	1' - 5 1/2"	5" STD	139' - 3 1/4"

- (12) If the outermost wing pipe runner is a non-sliding pipe runner, consider the next outermost wing pipe runner the shortest.
- (13) Quantities shown include, if present, the non-sliding pipes.
- (14) The anchor pipe size is the next smaller size than the pipe runner size.

SPECIAL NOTE:
Note that the tabular quantities are given for estimating purposes only. It is likely that these quantities will change due to field conditions. Therefore, verify all dimensions in the field prior to fabrication of the safety end treatment components.

Pipe Size	Pipe O.D.	Pipe I.D.
2" STD	2.375"	2.067"
3" STD	3.500"	3.068"
4" STD	4.500"	4.026"
5" STD	5.563"	5.047"

TOTAL PIPE LENGTHS FORMULAS:

$$\text{Total Length of All Pipe Runners} = \frac{\text{Total Length of Wingwall Pipe Runners}}{\text{No. of Wingwall Pipe Runners}} + \left(\frac{\text{No. of Headwall Pipe Runners}}{\text{Headwall Pipe Runners}} \right) \left(\frac{\text{Headwall Pipe Runner Length}}{\text{Pipe Runner Length}} \right)$$

$$\text{Total Length of All Anchor Pipes} = (3.000') \left(\frac{\text{No. of Wing Pipe Runners}}{\text{Pipe Runners}} + \frac{\text{No. of Headwall Pipe Runners}}{\text{Pipe Runners}} - \frac{\text{No. of Non-Sliding Pipe Runners}}{\text{Pipe Runners}} \right)$$

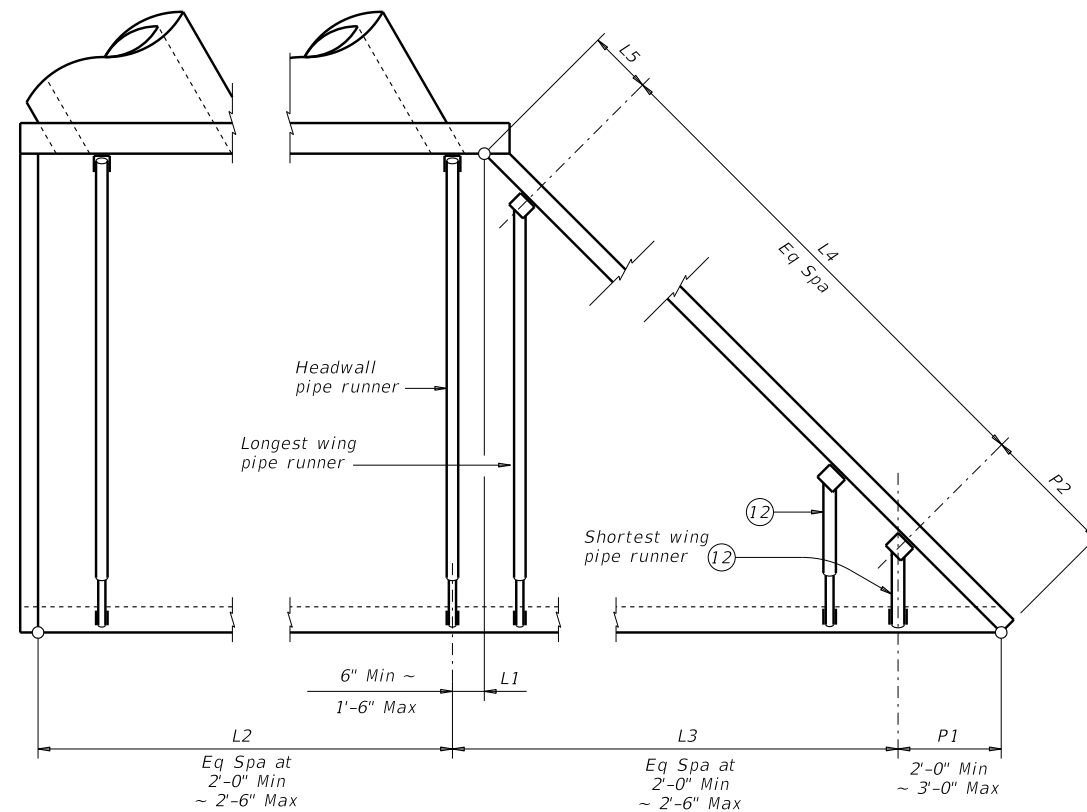

PIPE RUNNER LAYOUT

Note: Left forward culvert skew shown, actual culvert skew may be opposite hand.

		Bridge Division Standard	
SAFETY END TREATMENT WITH FLARED WINGS FOR 30° SKEW PIPE CULVERTS TYPE I ~ CROSS DRAINAGE			
SETP-FW-30			
FILE: CD-SETP-FW30-20.dgn	DN: GAF	CK: CAT	DW: TxDOT
©TxDOT February 2020	CONT	SECT	JOB
REVISIONS	COUNTY		SHEET NO.