

DISCLAIMER: This standard is governed by the "Texas Engineering Practice Act." No warranty of any kind is made by TxDOT for any purpose whatsoever. TxDOT assumes no responsibility for the conversion of this standard to other formats or for incorrect results or damages resulting from its use.

DATE: FILE:

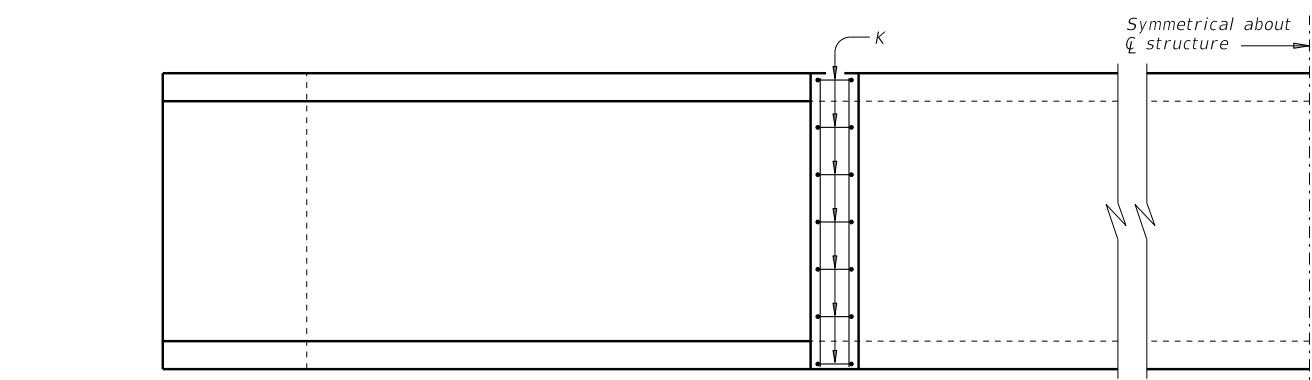

HALF PLAN

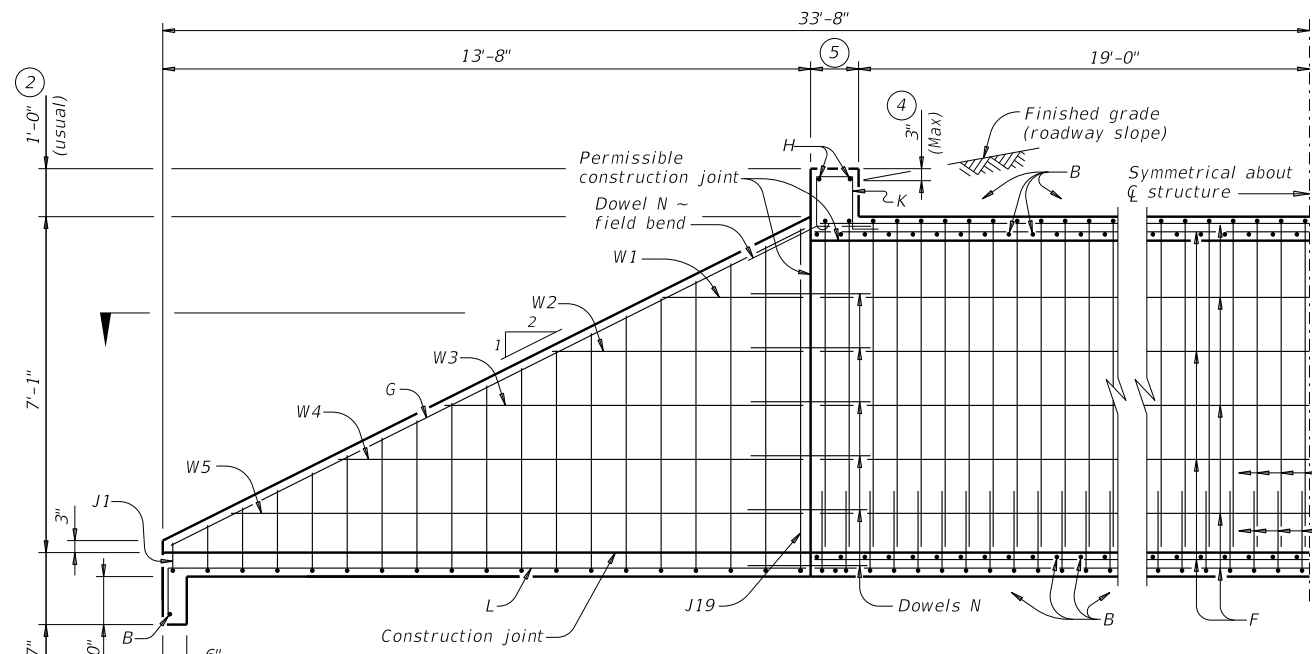

HALF SECTION

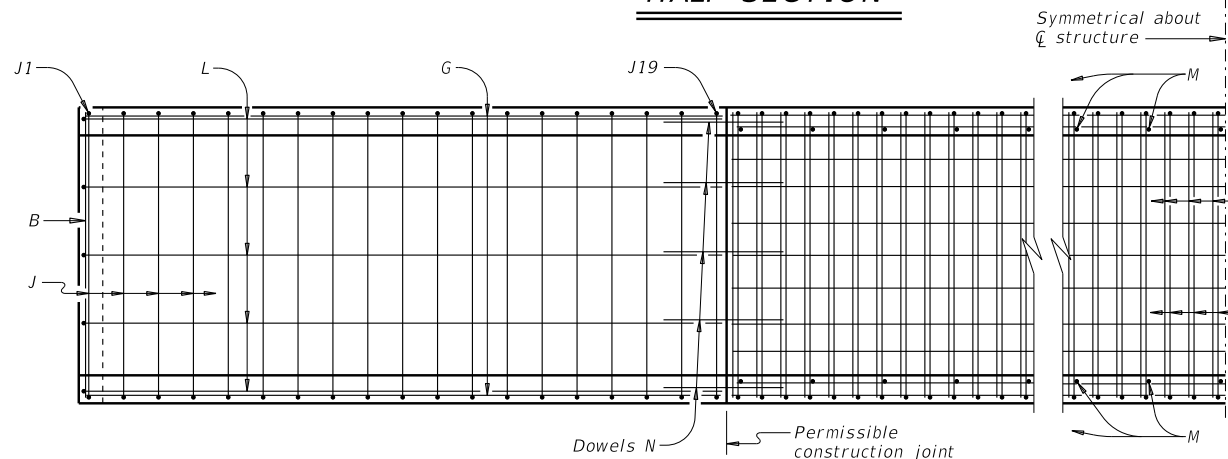

SECTION A-A

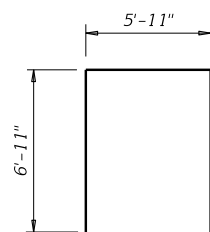

BARS C

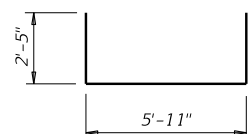

BARS D

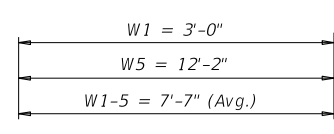

BARS W

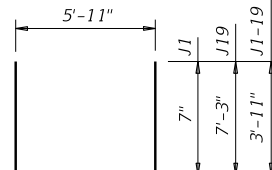

BARS J

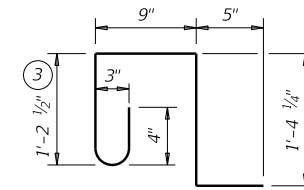

BARS K (#4)
(Spa = 1'-0" Max)
(Length = 4'-2")

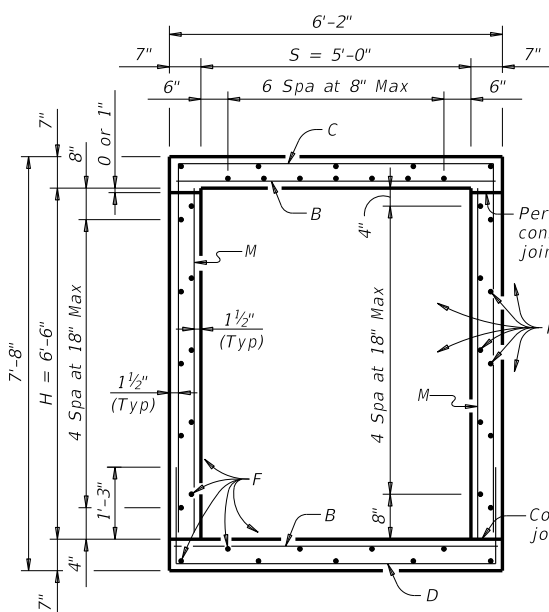

SECTION THRU BOX

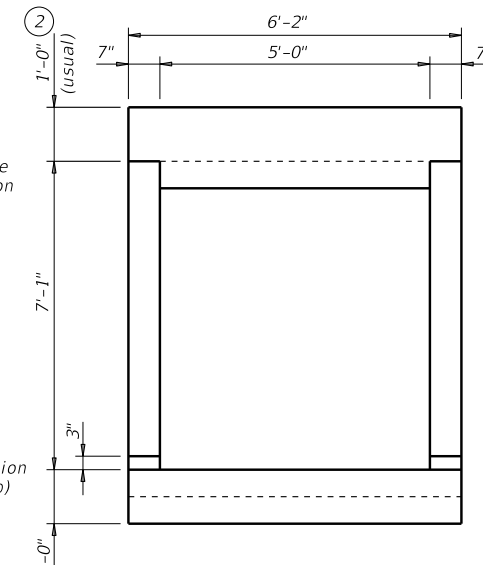

END ELEVATION

ESTIMATED QUANTITIES FOR ONE STOCK PASS

Bar	No.	Size	Spa	Length	Weight
B	163	#5	6"	5'-10"	992
C	81	#4	6"	19'-9"	1,069
D	81	#4	6"	10'-9"	582
F	41	#4	Shown	39'-8"	1,086
G	4	#4	~	15'-0"	40
H	4	#4	~	5'-10"	16
J1-19	38	#4	9"	13'-8"Av	347
K	14	#4	12"	4'-2"	39
L	10	#4	17"±	14'-4"	96
M	110	#4	9"	6'-6"	478
N	34	#6	~	3'-0"	153
W1-5	20	#4	~	7'-7"Av	101
Reinforcing Steel					Lb 5,002
Concrete					CY 30.6

- Quantities shown are for 38'-0" roadway width with two ends (4 wings and 2 aprons). For each 1'-0" variation in roadway width, make the following adjustments:
 - reinforcing steel, 104.3 lb.
 - concrete, 0.55 CY
 For boxes with no wings or with alternate wings, make the following adjustments:
 - omit Bars G, J, L, N, and W;
 - subtract 730 lb. from reinforcing steel total; and
 - subtract 8.3 CY from concrete total.
- 0" Min to 1'-0" Max. Estimated curb heights are shown elsewhere in the plans. For structures with T631 or T631LS bridge rail, refer to the Mounting Details for T631 & T631LS Rails (T631-CM) standard sheet. Refer to the Rail Anchorage Curb (RAC) standard sheet for structures with bridge rail other than T631 or T631LS.
- For curbs less than 1'-0" high, tilt Bars K or reduce bar height as necessary to maintain cover. For curbs less than 3" high, Bars K may be omitted.
- For vehicle safety, the following requirements must be met:
 - For structures without bridge rail, construct curbs no more than 3" above finished grade.
 - For structures with bridge rail, construct curbs flush with finished grade.
 Reduce curb heights, if necessary, to meet the above requirements. No changes will be made in quantities and no additional compensation will be allowed for this work.
- 1'-0" typical. 2'-3" when the Rail Anchorage Curb (RAC) standard sheet is referred to elsewhere in the plans.

The Contractor may replace Bars B, C, D, F, or M with deformed welded wire reinforcement (WWR) meeting the requirements of ASTM A1064. The area of required reinforcement may be reduced by the ratio of 60 ksi / 70 ksi. Spacing of WWR is limited to 4" Min and 18" Max. When required, provide lap splices in the WWR of the same length required for the equivalent bar size, rounded up for wire sizes between conventional bar sizes. The lap length required for WWR is never less than the lap length required for uncoated #4 bars.

Example conversion: Replacing Gr 60 #4 Bars at 9" Spacing with WWR
 Required WWR = (0.20 sq. in. per 0.75 ft.) x (60 ksi / 70 ksi) = 0.229 sq. in. per ft.
 If D23 wire is used to meet the 0.229 sq. in. per ft. requirement in this example, the required spacing = (0.230 sq. in.) / (0.229 sq. in. per ft.) x (12 in. per ft.) = 12.05" Max spacing. Required lap length for the provided D19.6 wire is 2'-1" (the same minimum lap length required for uncoated #5 bars, as listed under MATERIAL NOTES.)

CONSTRUCTION NOTES:

- Do not use permanent forms.
- Chamfer the bottom edge of the top slab 3" at the entrance.
- Adjust reinforcing bars to provide a minimum of 1 1/2" clear cover.
- Optionally, raise construction joints shown at the flow line by a maximum of 6". If this option is taken, Bars M may be cut off or raised and Bars C and Bars D may be reversed.

MATERIAL NOTES:

- Provide Grade 60 reinforcing steel.
- Provide galvanized reinforcing steel if required elsewhere in the plans.
- Provide Class C concrete (f'c = 3,600 psi) for culvert barrel and curb, with the following exceptions: provide Class S concrete (f'c = 4,000 psi) for the top slabs of:
 - culverts with overlay,
 - culverts with 1-to-2 course surface treatment, or
 - culverts with the top slab as the final riding surface.
- Provide bar laps, where required, as follows:
 - Uncoated or galvanized ~ #4 = 1'-8"
 - Uncoated or galvanized ~ #5 = 2'-1"
 - Uncoated or galvanized ~ #6 = 2'-6"

GENERAL NOTES:

- Designed according to AASHTO LRFD Bridge Design Specifications for the range of fill heights shown. See the Single Box Culverts Cast-In-Place Miscellaneous Details (SCC-MD) standard sheet for lengthening details.
- For wingwalls other than those shown here, refer to wingwall standards and details shown elsewhere in the plans.

Cover dimensions are clear dimensions, unless noted otherwise. Reinforcing bar dimensions shown are out-to-out of bar.

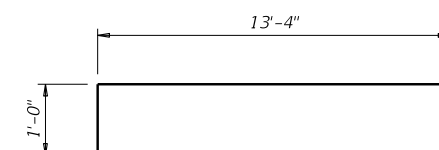

BARS L

HL93 LOADING



STOCK PASS
SIZE 5'-0" x 6'-6"
0' TO 14' FILL

SP

FILE: CD-SP-20.dgn	DN: TBE	CK: TAR	DW: TxDOT	CK: TxDOT
©TxDOT February 2020	CONT	SECT	JOB	HIGHWAY
REVISIONS	DIST	COUNTY	SHEET NO.	