

DISCLAIMER: The use of this standard is governed by the "Texas Engineering Practice Act." No warranty of any kind is made by TxDOT for any purpose whatsoever. TxDOT assumes no responsibility for the conversion of this standard to other formats or for incorrect results or damages resulting from its use.

DATE: FILE:

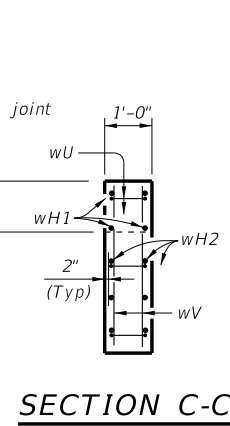
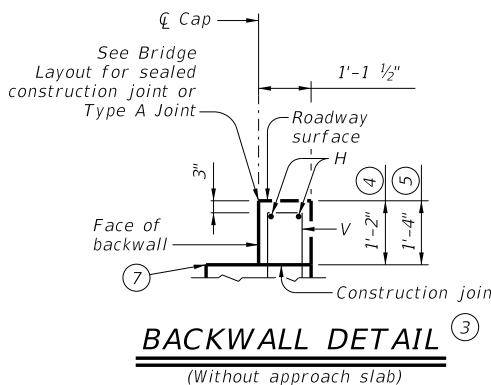
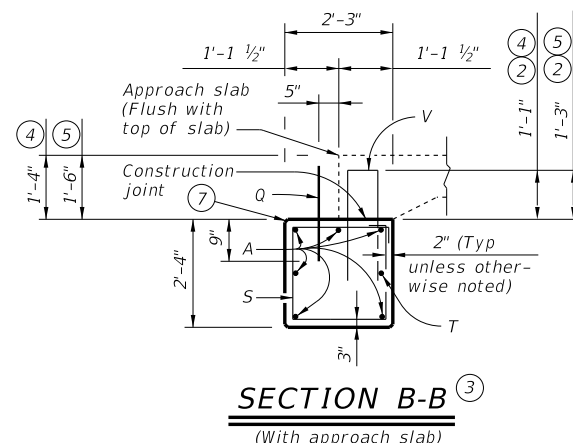
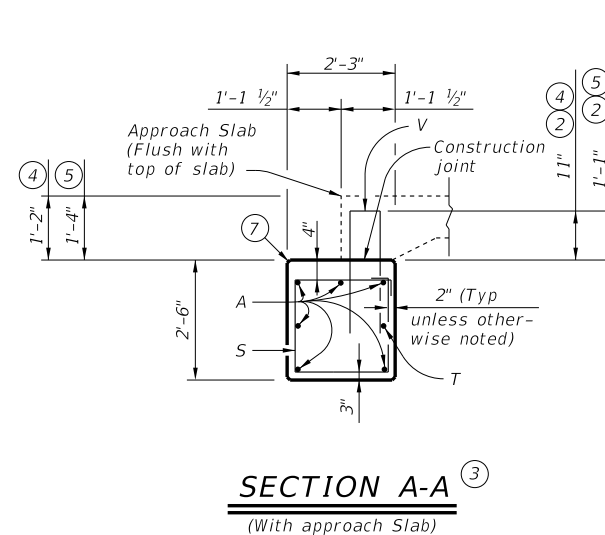
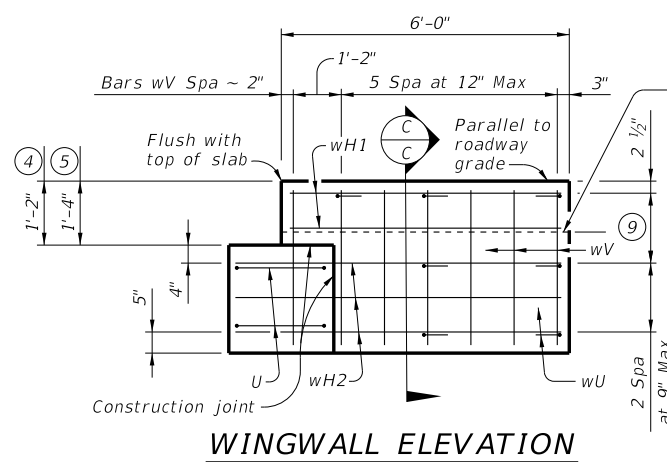
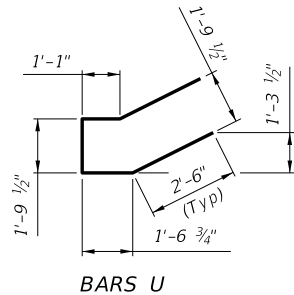
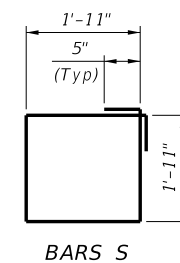
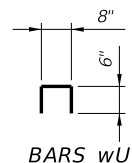
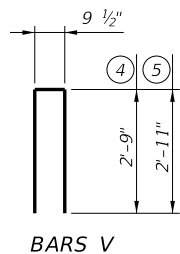
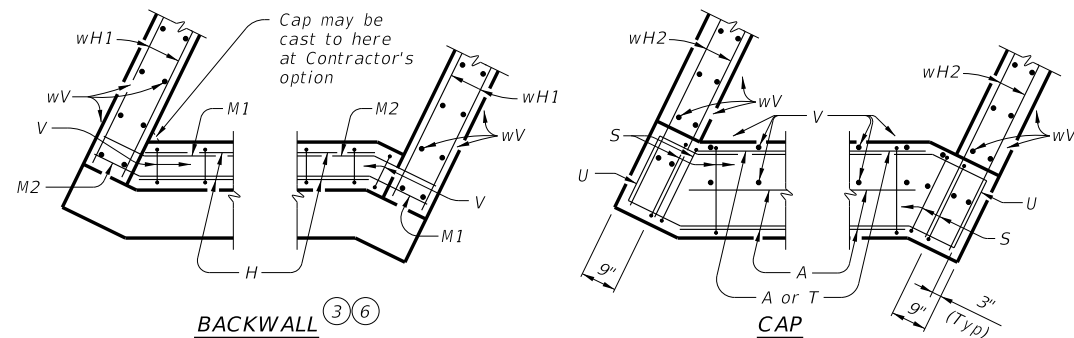
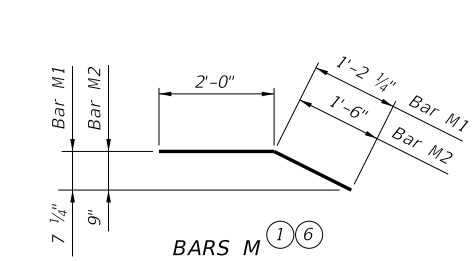
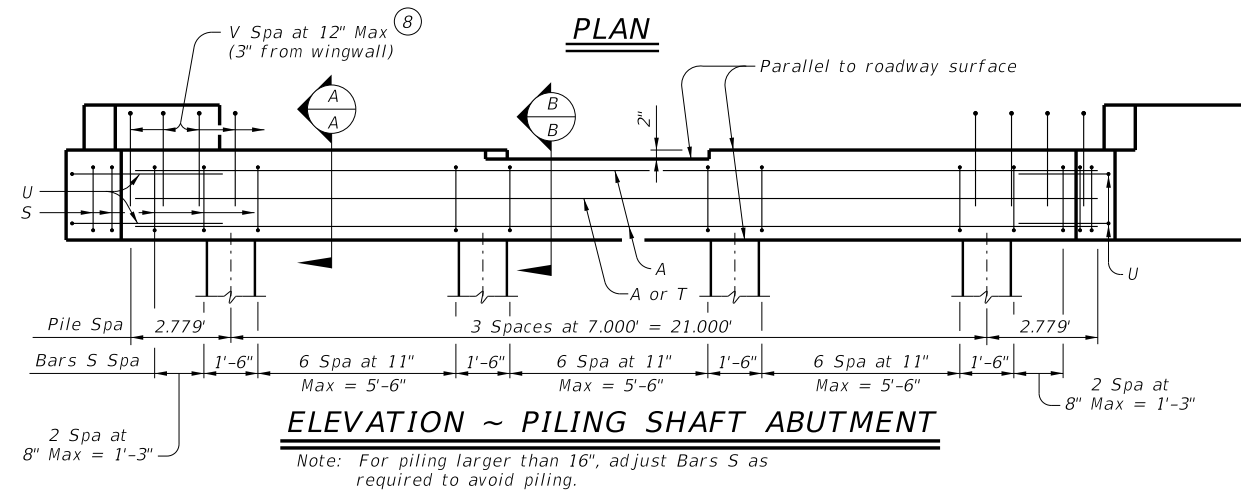
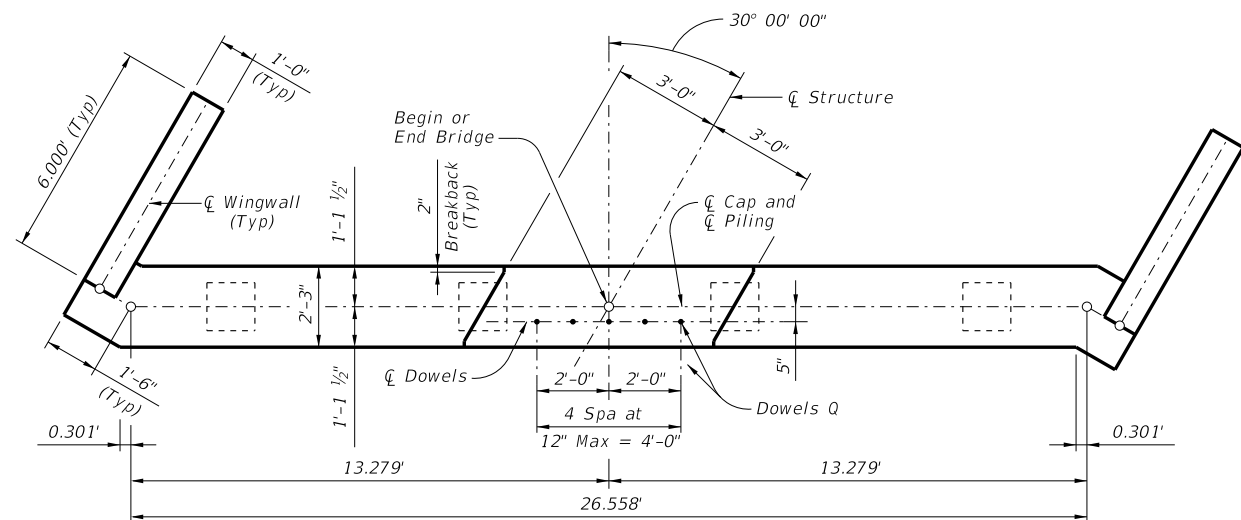

TABLE OF ESTIMATED QUANTITIES (1)

14" SLAB					16" SLAB						
Bar	No.	Size	Length	Weight	Bar	No.	Size	Length	Weight		
A	6	#11	26'-7"	847	A	6	#11	26'-7"	847		
Q	5	#6	1'-6"	11	Q	5	#6	1'-6"	11		
S	31	#4	8'-6"	176	S	31	#4	8'-6"	176		
T	1	#5	26'-7"	28	T	1	#5	26'-7"	28		
U	4	#6	9'-5"	57	U	4	#6	9'-5"	57		
V	29	#5	6'-4"	192	V	29	#5	6'-8"	202		
wH1	8	#6	5'-8"	68	wH1	8	#6	5'-8"	68		
wH2	12	#6	6'-10"	123	wH2	12	#6	6'-10"	123		
wU	14	#4	1'-8"	16	wU	14	#4	1'-8"	16		
wV	28	#5	3'-4"	97	wV	28	#5	3'-6"	102		
Reinforcing Steel				Lb	1,615	Reinforcing Steel				Lb	1,630
CI "C" Conc (Abut)				CY	7.5	CI "C" Conc (Abut)				CY	7.6

- Quantities shown are for one abutment only (with approach slab). Without approach slab, add 69 Lbs reinforcing steel for the following:
 2 ~ #5 Bars H (26'-7")
 2 ~ #5 Bars M1 (3'-2")
 2 ~ #5 Bars M2 (3'-6")
 Add the following amounts of concrete:
 14" slab thickness add 1.3 CY Class "C" Concrete.
 16" slab thickness add 1.5 CY Class "C" Concrete.
- Increase as required to maintain 3" from finished grade.
- See Bridge Layout to determine if approach slab is present.
- Use with 14" slab thickness.
- Use with 16" slab thickness.
- Omit Bars H and M if approach slab is present.
- See CS-MD standard for preformed bituminous fiber material.
- Field bend as needed to clear piles.
- Spacing based on slab depth
 14" ~ 2 spaces at 8" Max.
 16" ~ 2 spaces at 9" Max.

MATERIAL NOTES:

Provide Class C concrete (f'c = 3,600 psi).
 Provide Class C (HPC) concrete if shown elsewhere in the plans.
 Provide Grade 60 reinforcing steel.

GENERAL NOTES:

Designed according to AASHTO LRFD Bridge Design Specifications. Details shown are for right forward skew. See Bridge Layout for actual skew direction.
 Designed for normal embankment header slope of 3:1.
 See Bridge Layout for foundation type, size and length.
 See Common Foundation Details (FD) standard sheet for foundation details and notes.
 See Concrete Riprap (CRR) standard sheet or Stone Riprap (SRR) standard sheets for riprap attachment details, if applicable.
 See applicable rail details for anchorage in wingwalls.
 See Miscellaneous Details for C-I-P Concrete Slab Spans (CS-MD) standard sheet for joint details and details not shown.
 Calculated Foundation Loads: 25 Tons/pile.
 These abutment details may be used with standards CS-25-24, CS-50-24-30, CS-75-24-30, and CS-80-24-30 only.

Cover dimensions are clear dimensions, unless noted otherwise. Reinforcing bar dimensions shown are out-to-out of bar.

HL93 LOADING

		Bridge Division Standard	
ABUTMENTS FOR C-I-P CONC SLAB SPANS 24' ROADWAY 30° SKEW (PILES) ACSP-24-30			
FILE: CS-ACS2430P-21.dgn	DN: HTP	CK: SDC	DW: LJC
©TxDOT July 2021	CONT	SECT	JOB
REVISIONS			HIGHWAY
	DIST	COUNTY	SHEET NO.