

DISCLAIMER: The use of this standard is governed by the "Texas Engineering Practice Act". No warranty of any kind is made by TxDOT for any purpose whatsoever. TxDOT assumes no responsibility for the conversion of this standard to other formats or for incorrect results or damages resulting from its use.

DATE:
FILE:

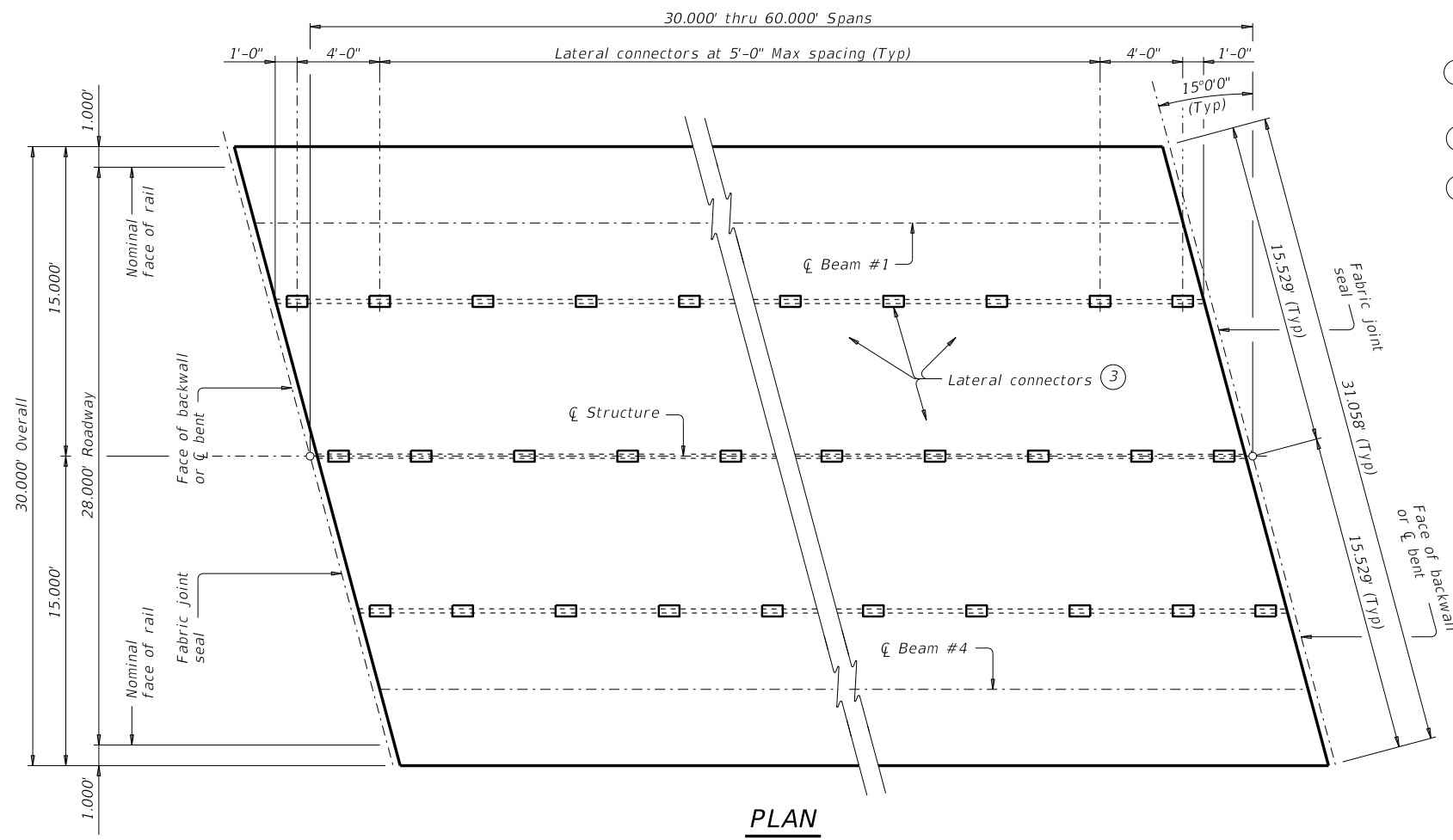

PLAN

- ① Based on theoretical beam camber, dead load deflections of two-course surface treatment and 2" ACP overlay, and a constant grade.
- ② This standard does not provide for changes in roadway cross-slopes within the structure.
- ③ See Lateral Connector Details.

TABLE OF VARIABLE VALUES					
SPAN LENGTH	BEAM TYPE	DEAD LOAD DEFLECTIONS		SECTION DEPTHS ①	
		"A"	"B"	"X" AT \bar{C} BEARING	"Y" AT \bar{C} BEARING
Ft		Ft	Ft	In	Ft/In
30	7DS20	0.001	0.001	2 1/2"	1'-10 1/2"
35	7DS20	0.001	0.002	2 3/4"	1'-10 3/4"
40	7DS20	0.002	0.003	3"	1'-11"
45	7DS20	0.004	0.005	3 1/2"	1'-11 1/2"
50	7DS20	0.006	0.008	4"	2'-0"
30	7DS23	0.001	0.001	2 1/2"	2'-1 1/2"
35	7DS23	0.001	0.001	2 1/2"	2'-1 1/2"
40	7DS23	0.002	0.002	2 3/4"	2'-1 3/4"
45	7DS23	0.002	0.003	3"	2'-2"
50	7DS23	0.004	0.005	3 1/4"	2'-2 1/4"
55	7DS23	0.006	0.008	3 3/4"	2'-2 3/4"
60	7DS23	0.008	0.011	4 1/2"	2'-3 1/2"

MATERIAL NOTES:
Provide Grade 36 or 50 Lateral Connector Rods (LCR).

GENERAL NOTES:
Designed according to AASHTO LRFD Bridge Design Specifications.
See applicable railing details and standard Prestressed Concrete Decked Slab Beams Rail Anchorage Details (DSBRA) for rail anchorage.
This standard does not support the use of transition bents.
This standard is drawn showing right forward skew. See Bridge Layout for actual skew direction.
These details do not accommodate crest of sag roadway vertical curves on the span.
It is recommended, with crown cross-slope, to erect beams adjacent to crown point first. For structures without a crown-point, it is recommended to erect beams on the high side of cross-slope first and progress to the low side.
Payment for the following is considered subsidiary to the other bid items: packaged non-metallic, non-shrink cementitious grout; corrosion inhibiting bonding agent; fabric underseal; work performed; materials furnished; and curing time.
Payment for fabric joint seal is considered subsidiary to other bid items.

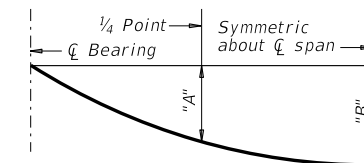

Deflections shown are due to two-course surface treatment and 2" ACP overlay only, ($E_c = 5000$ ksi). Calculated deflections shown are theoretical and actual dimension may be less. Adjust based on field verifications.

DEAD LOAD DEFLECTION DIAGRAM

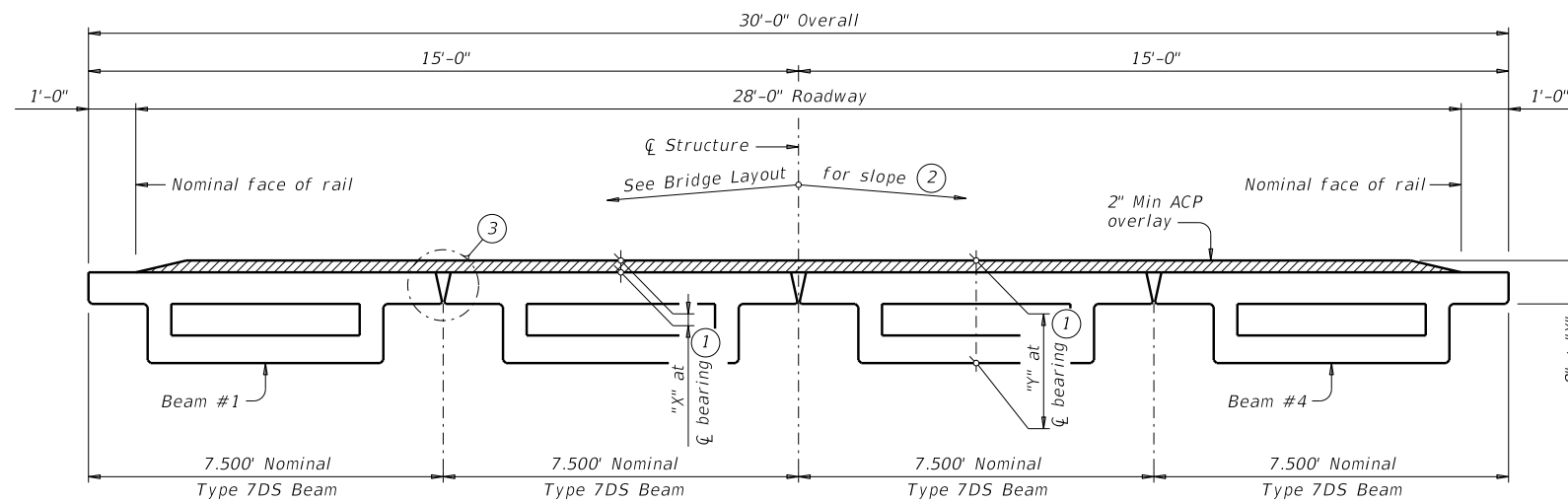

TYPICAL TRANSVERSE SECTION

HL93 LOADING SHEET 1 OF 2

Texas Department of Transportation

PRESTRESSED CONCRETE DECKED SLAB BEAM SPANS
(TYPE 7DS20 OR 7DS23)
28' ROADWAY 15° SKEW
SDSB-28-15

FILE: DSB-SDSB2815-20.dgn	DN: JLR	CK: SDC	DW: SFS	CK: JLR
©TxDOT August 2020		CONT	SECT	HIGHWAY
REVISIONS		DIST	COUNTY	SHEET NO.

TABLE OF ESTIMATED QUANTITIES

SPAN LENGTH	BEAM TYPE	PRESTRESSED CONCRETE DECKED SLAB BEAMS (4)		
		ABUTMENT TO INTERIOR BENT	INTERIOR BENT TO INTERIOR BENT	ABUTMENT TO ABUTMENT
Ft		LF	LF	LF
30	7DS20	119.48	119.65	119.31
35	7DS20	139.48	139.65	139.31
40	7DS20	159.48	159.65	159.31
45	7DS20	179.48	179.65	179.31
50	7DS20	199.48	199.65	199.31
30	7DS23	119.48	119.65	119.31
35	7DS23	139.48	139.65	139.31
40	7DS23	159.48	159.65	159.31
45	7DS23	179.48	179.65	179.31
50	7DS23	199.48	199.65	199.31
55	7DS23	21		

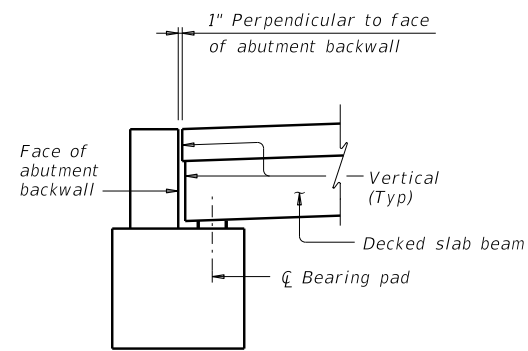

AT ABUTMENT

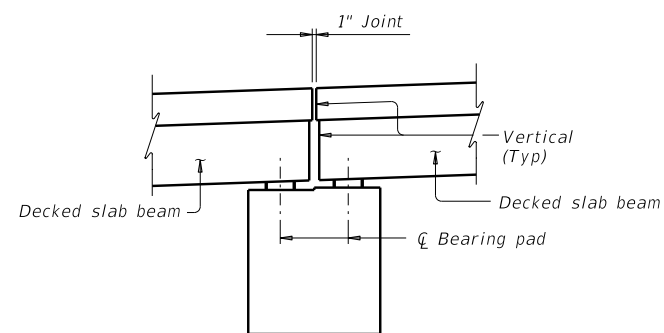

AT INTERIOR BENT

STANDARD BEAM END ELEVATIONS

(ACP overlay not shown for clarity.)

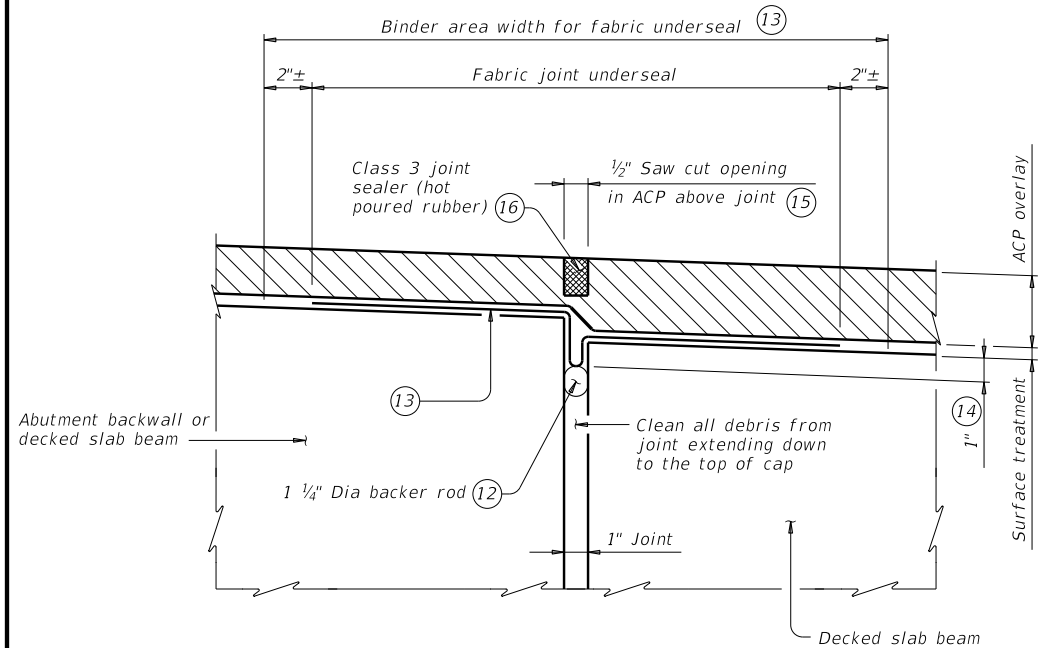

FABRIC JOINT SEAL (11)

(Showing expansion joint with ACP overlay.)

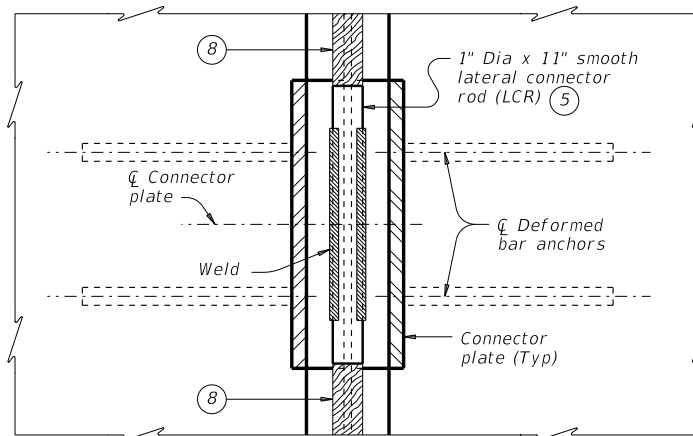

PLAN

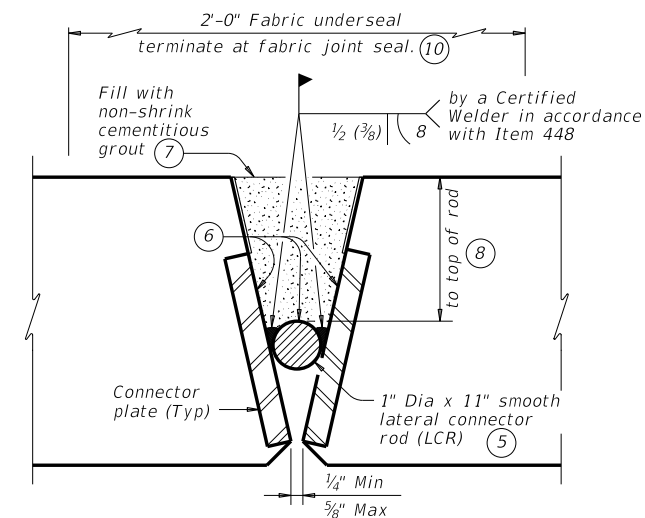

SECTION

LATERAL CONNECTOR DETAILS (9)

Do not apply load to beams while welding lateral connector rods. No vehicles are allowed on the span until shear key grout has cured 72 hours.

HL93 LOADING

SHEET 2 OF 2

		Bridge Division Standard				
				FILE:	DN:	CK:
©TxDOT August 2020		CONT	SECT	JOB	HIGHWAY	
REVISIONS		DIST	COUNTY		SHEET NO.	

DATE:
FILE: