

DISCLAIMER: This sheet is to be used as a guide for installation of a system to facilitate removal of bats from a bridge. The Bat Exclusion system is meant to allow a means of egress from an existing roost while preventing re-entry to the roost. If exact conditions are not reflected, details and notes must be developed to reflect the specific conditions of the particular project. These sheets cannot be used without modification and in all cases, details and notes not required must be removed. This note and the phrase "Not to be used as a standard" must be removed and the sheets must be signed and sealed by a Professional Engineer.

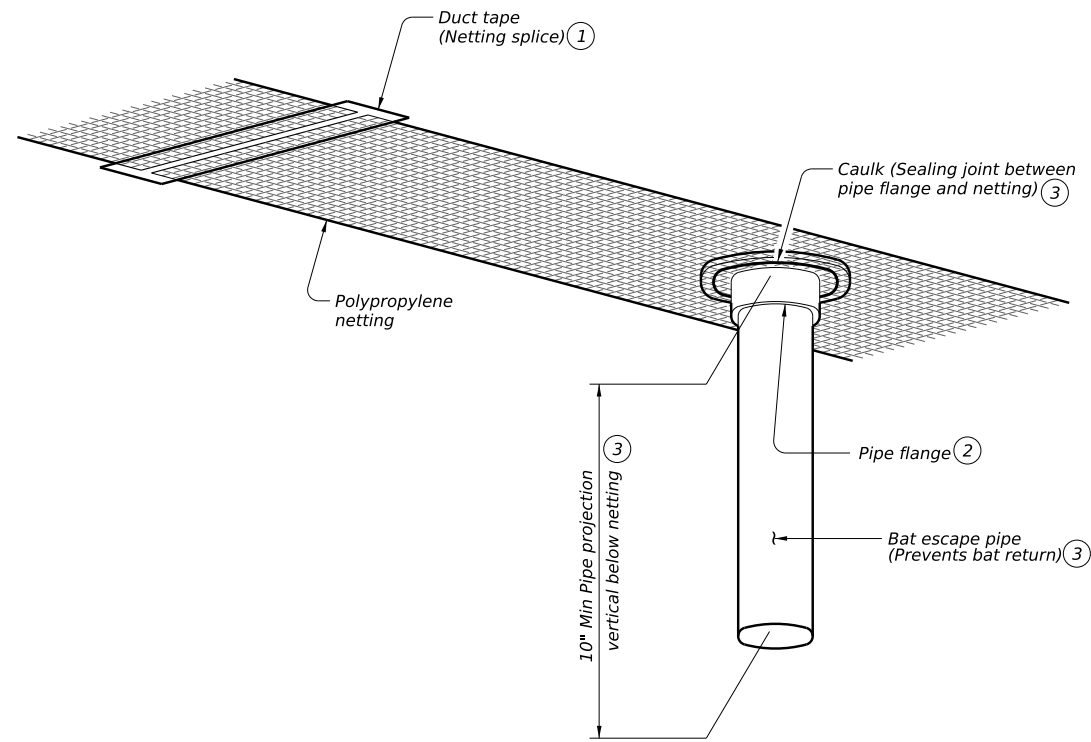

TYPICAL BAT EXCLUSION SYSTEM DETAIL

Shown from below.

- ① When making a continuous run of netting, butt the net ends together and "sandwich" between two strips of 2" duct tape (running the complete width of net joint and centered on the joint). Thoroughly press the tape to ensure that no gaps are present.
- ② Attach the flat flange fitting to the pipe according to the pipe supplier's recommendations.
- ③ Cut an opening in the netting, as located in the details, that snugly fits around the pipe flange. Insert the flanged pipe into the opening so that the flat of the flange rests on the netting. Thoroughly caulk the net to flange overlap to ensure that no gaps are present. (Note that the flanged pipe will hang from the net and will not be directly attached to the host structure.)
- ④ Thoroughly caulk the net to the host structure to ensure that no gaps are present to permit the passage of bats and that the bond is adequate to support the weight of the installation and bats that are attempting to leave or re-enter the roost.
- ⑤ Place a bat escape pipe adjacent to and inboard of each corner of the drop inlet.

NOTE TO DESIGNER:
 This sheet is to be used as a guide for installation of a system to facilitate removal of bats from a bridge. The Bat Exclusion system is meant to allow a means of egress from an existing roost while preventing re-entry to the roost. If exact conditions are not reflected, details and notes must be developed to reflect the specific conditions of the particular project.
 These sheets cannot be used without modification and in all cases, details and notes not required must be removed. This note and the phrase "Not to be used as a standard" must be removed and the sheets must be signed and sealed by a Professional Engineer.

SAFETY NOTES:
 When working around bats and their roosts, at minimum, provide the following listed safety gear for worker use:
 - Goggle style eye protection,
 - Respirator filter masks (Hepa filters recommended), and
 - Gloves.
 Require that workers wear long-sleeved shirts. Note that in extremely contaminated environments, more extensive protection may be required.
 Avoid direct skin contact with the bats or their waste products. Avoid breathing dust containing bat waste products.

CONSTRUCTION NOTES:
 Thoroughly fasten edges of exclusion netting with caulk ensuring that there are no gaps that will permit the passage of bats. After installation is complete, inspect the installation daily for the first seven days and once a week thereafter to ensure that the exclusion system is properly functioning, has covered all access points, and has not been damaged.
 For culvert applications, remove the Bat Exclusion System after all other culvert work is completed and use a wire brush to clean any caulk remnants from the concrete.

MATERIAL NOTES:
 Provide the following component materials as listed below:
 - Polypropylene plastic netting; mesh size of 1/10 inch (2.4 mm) minimum to 1/8 inch (4 mm) maximum
 - PVC or PE pipe; 2 inch (54 mm) inside diameter, smooth, unperforated
 - Flat pipe flange fitting pipe named above
 - Caulk; non-toxic, for concrete and masonry, silicone
 - Duct tape; 2 inch

GENERAL NOTES:
 The Bat Exclusion System is intended to provide an efficient and humane method of evicting bats from and preventing their return to roosts of opportunity in Texas Department of Transportation structures. Ensure that materials supplied and methods used to install the exclusion system are non-toxic and are safe for longterm animal contact.
 Details shown herein reflect installation on the open, longitudinal joint (running full length of bridge) under the median barrier and installation covering the existing drop inlet opening in the top slab of a culvert.
 Protect other locations adjacent to the joint opening where the BES is installed such as transverse gaps at the abutments, between ends of beams, etc. and other locations as identified by the Engineer that will permit either access to the joint or that will provide an alternate roost. Protection method includes inserting compressible material such as backer rod or foam rubber into such openings so as to completely block bat access and placing caulk along the exposed edges of the installed compressible material to prevent dislodgement.
 See Statewide Special Specification 5004, "Bat Exclusion System" for payment and for notes not included on this sheet.

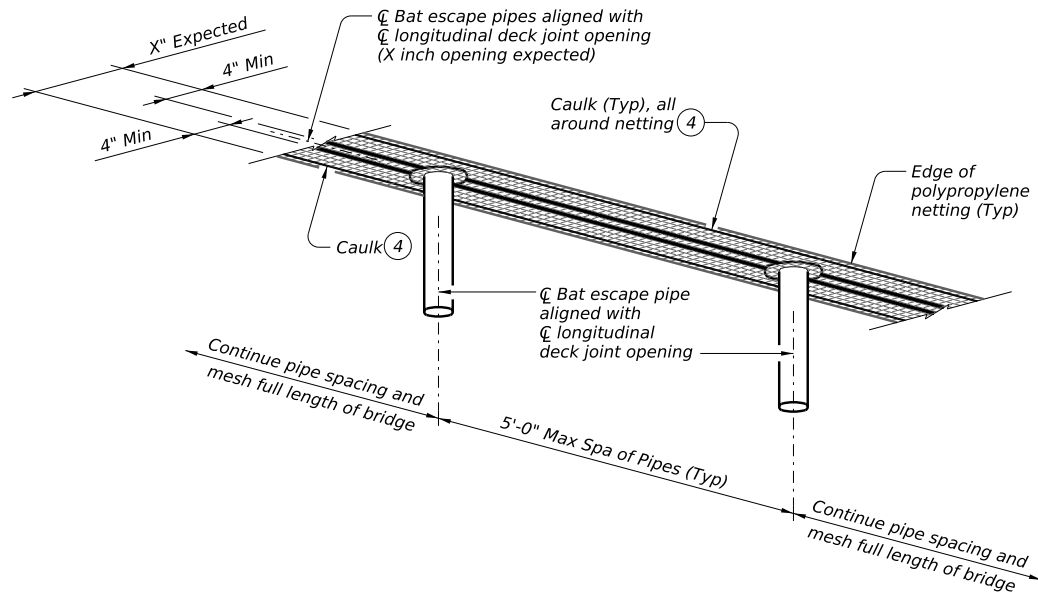

BRIDGE DECK JOINT

Shown from below.

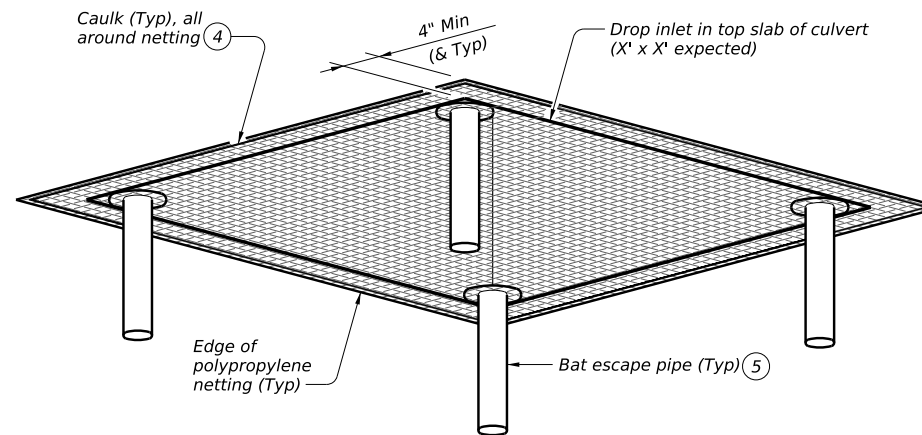

DROP INLET AT CULVERT

Shown from below.

P.E. SEAL
 REQUIRED
PRELIMINARY
 SUBJECT TO REVISION

This document is released for informational purposes under the authority of XXX XXXX.
 P.E. XXXXX on XX/XX/XX.
 It is not to be used for regulatory approval, permit, bidding, or construction purposes.

		Bridge Division Standard	
BAT EXCLUSION SYSTEM			
(Not to be used as a standard) NBI: XX-XXX-XXXX-XX-XXX			
FILE: E-BES-24.dgn	DN: TxDOT	CK: TxDOT	DW: TxDOT
©TxDOT June 2024	CONT	SECT	JOB
REVISIONS	COUNTY		SHEET NO.

DATE:
 FILE: