

DISCLAIMER: This standard is governed by the "Texas Engineering Practice Act". No warranty of any kind is made by TxDOT for any purpose whatsoever. TxDOT assumes no responsibility for the conversion of this standard to other formats or for incorrect results or damages resulting from its use.

DATE: FILE:

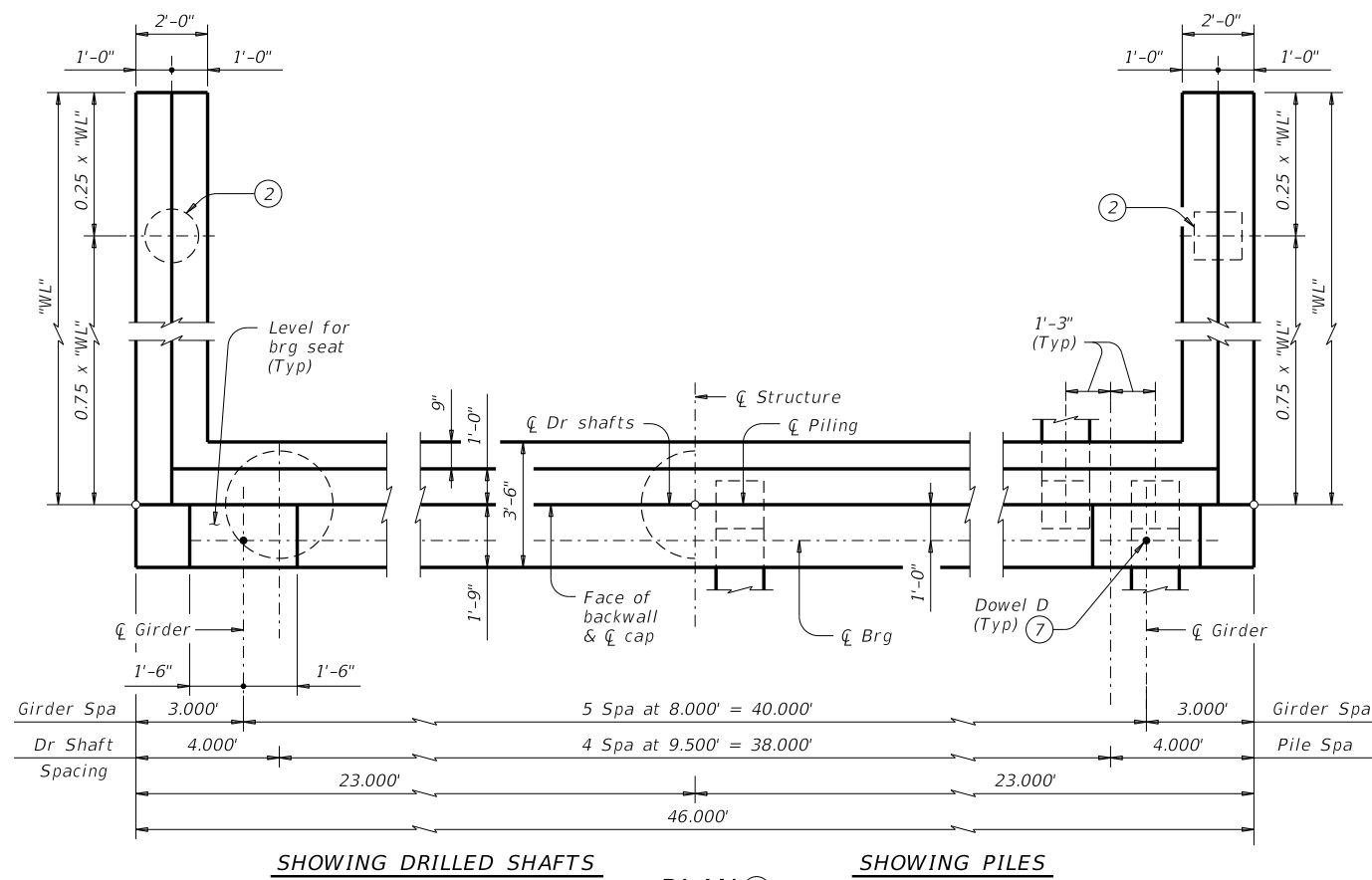

PLAN 1

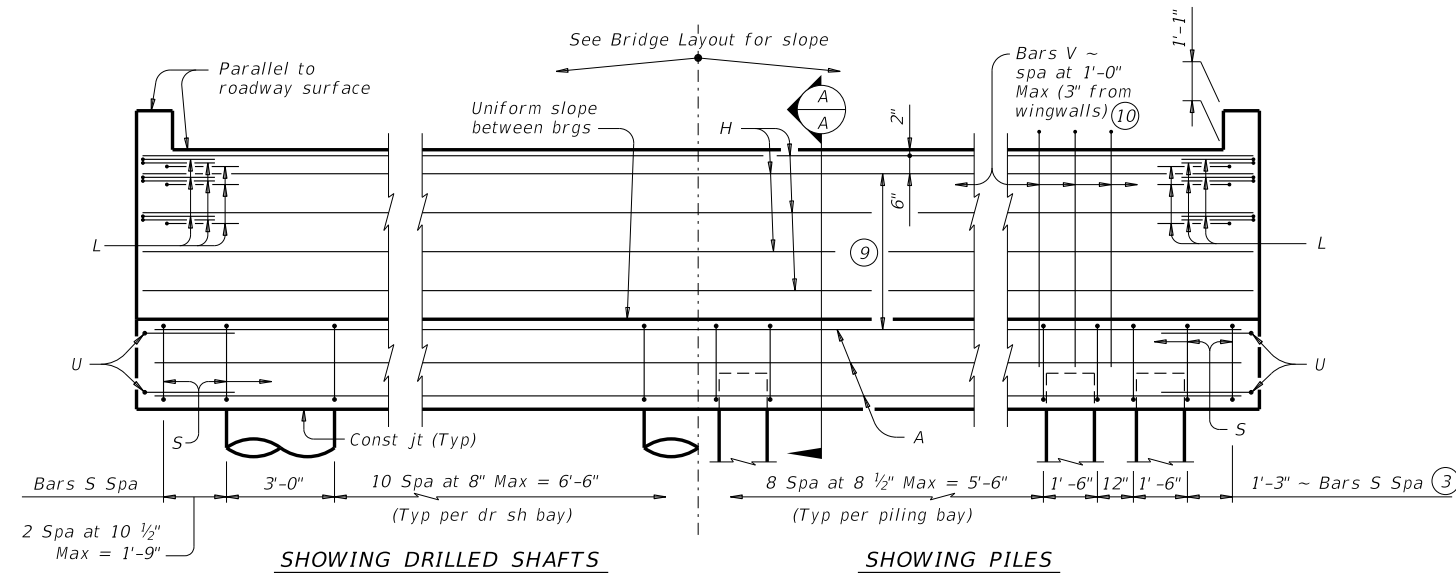

ELEVATION

Header Slope	Girder Type	Wingwall Type	Wingwall Lgth "WL"
2:1	Tx28	Cantilevered	8.000'
	Tx34	Cantilevered	9.000'
	Tx40	Cantilevered	10.000'
	Tx46	Cantilevered	11.000'
	Tx54	Cantilevered	12.000'
3:1	Tx28	Cantilevered	12.000'
	Tx34	Founded	13.000'
	Tx40	Founded	15.000'
	Tx46	Founded	16.000'
	Tx54	Founded	18.000'

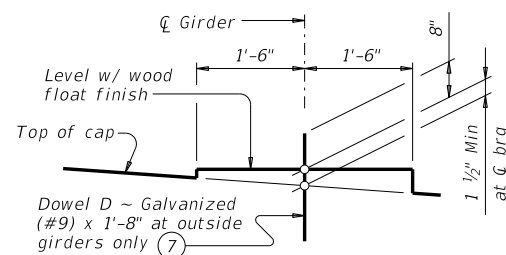

BEARING SEAT DETAIL

(Bearing surface must be clean and free of all loose material before placing bearing pad.)

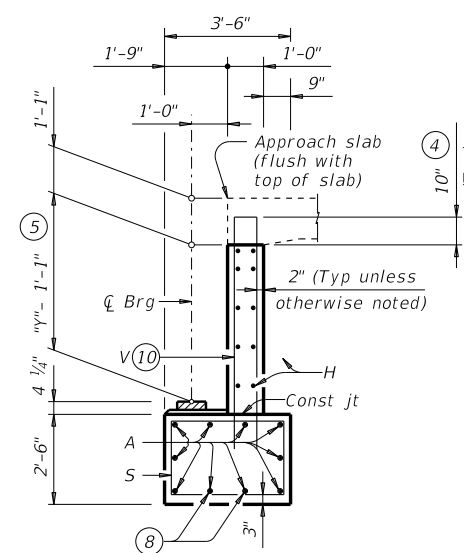

SECTION A-A

(With approach slab) 6

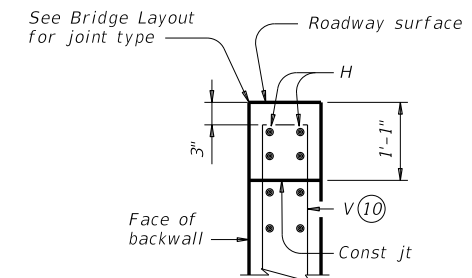

BACKWALL DETAIL

(Without approach slab) 6

- 1 See Table A for variable dimensions based on header slope and girder type.
- 2 See Table A to determine if wingwall foundations are required.
- 3 For piling larger than 16" adjust Bars S spacing as required to avoid piling.
- 4 Increase as required to maintain 3" from finished grade.
- 5 See Span details for "Y" value.
- 6 See Bridge Layout to determine if approach slab is present.
- 7 Omit Dowels D at end of multi-span unit. Adjust reinforcing steel total accordingly.
- 8 With pile foundations, move Bars A shown to clear piles.
- 9 Spacing based on girder type:
Tx28 ~ 3 spaces at 1'-0" Max
Tx34 ~ 3 spaces at 1'-0" Max
Tx40 ~ 4 spaces at 1'-0" Max
Tx46 ~ 4 spaces at 1'-0" Max
Tx54 ~ 5 spaces at 1'-0" Max
- 10 Field bend as needed to clear piles.

TABLE OF FOUNDATION LOADS

Span Length	All Girder Types	
	Tons/Shaft	Tons/Pile
40	55	51
45	59	53
50	63	55
55	66	56
60	70	58
65	73	60
70	77	62
75	80	64
80	84	66
85	87	67
90	91	69
95	94	71
100	98	73
105	101	74
110	104	76
115	108	78
120	111	80
125	114	81

GENERAL NOTES:

Designed according to AASHTO LRFD Bridge Design Specifications.
See Bridge Layout for header slope and foundation type, size and length.
See Common Foundation Details (FD) standard sheet for all foundation details and notes.
See Concrete Riprap (CRR) standard sheet or Stone Riprap (SRR) standard sheet for riprap attachment details, if applicable.
See applicable rail details for rail anchorage in wingwalls.
These abutment details may be used with standard SIG-44 only.

Cover dimensions are clear dimensions, unless noted otherwise.
Reinforcing bar dimensions shown are out-to-out of bar.

MATERIAL NOTES:

Provide Class C concrete ($f'c = 3,600$ psi).
Provide Class C (HPC) concrete if shown elsewhere in the plans.
Provide Grade 60 reinforcing steel.
Galvanize dowel bars D.

HL93 LOADING

SHEET 1 OF 3



ABUTMENTS
TYPE TX28 THRU TX54
PRESTR CONC I-GIRDERS
44' ROADWAY

AIG-44

FILE: IG-AIG4400-23.dgn	DN: TAR	CK: KCM	DW: JTR	CK: TAR
©TxDOT August 2017	CONT	SECT	JOB	HIGHWAY
REVISIONS				
10-2023 - Stirrup Spa	DIST	COUNTY		SHEET NO.

DISCLAIMER: This standard is governed by the "Texas Engineering Practice Act". No warranty of any kind is made by TxDOT for any purpose whatsoever. TxDOT assumes no responsibility for the conversion of this standard to other formats or for incorrect results or damages resulting from its use.

DATE:
FILE:

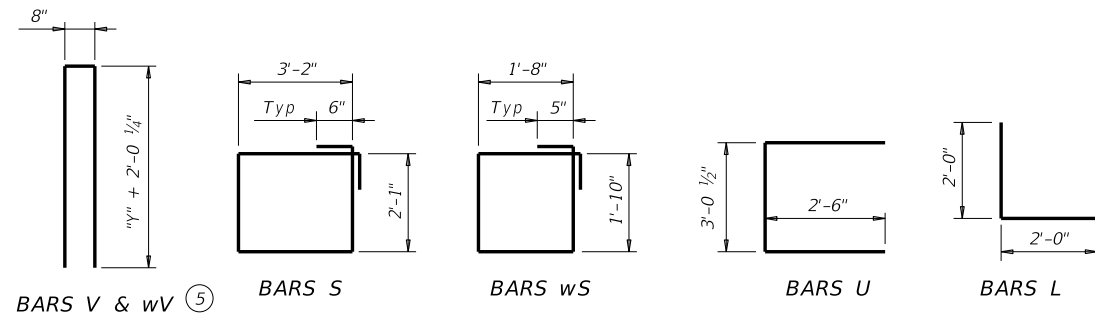
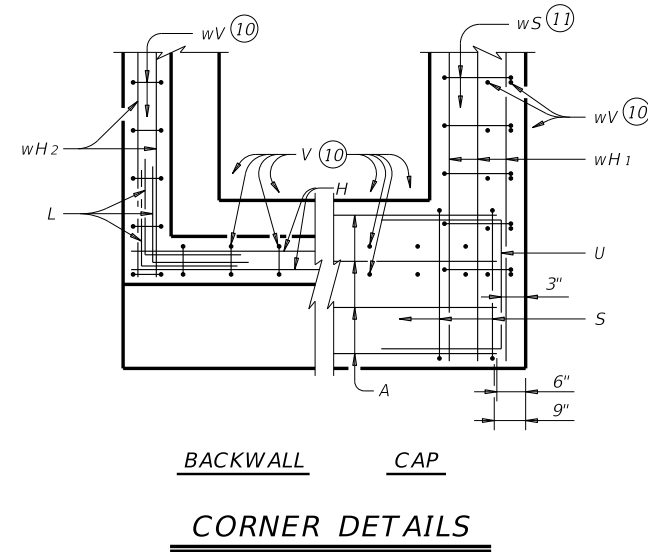
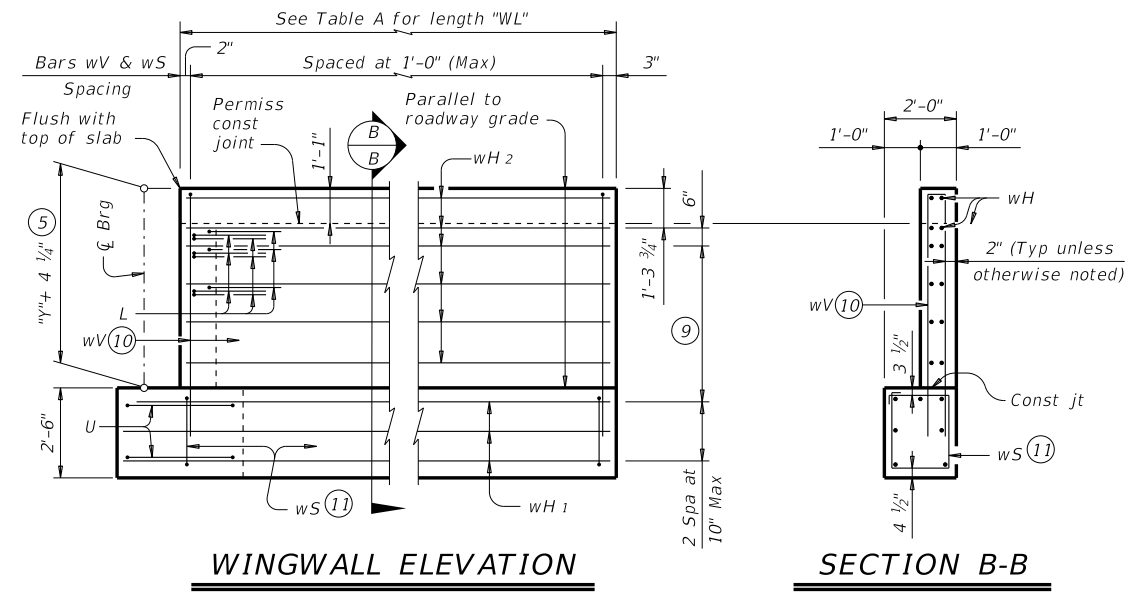

- ⑤ See Span details for "y" value.
- ⑨ Spacing based on girder type:
Tx28 ~ 3 spaces at 1'-0" Max
Tx34 ~ 3 spaces at 1'-0" Max
Tx40 ~ 4 spaces at 1'-0" Max
Tx46 ~ 4 spaces at 1'-0" Max
Tx54 ~ 5 spaces at 1'-0" Max
- ⑩ Field bend as needed to clear piles.
- ⑪ Adjust as required to avoid piling.

HL93 LOADING

SHEET 2 OF 3



ABUTMENTS
TYPE TX28 THRU TX54
PRESTR CONC I-GIRDERS
44' ROADWAY

AIG-44

FILE: IG-AIG4400-23.dgn	DN: TAR	CK: KCM	DW: JTR	CK: TAR
©TxDOT August 2017	CONT	SECT	JOB	HIGHWAY
REVISIONS				
10-2023 - Stirrup Spa	DIST	COUNTY		SHEET NO.

DISCLAIMER: This standard is governed by the "Texas Engineering Practice Act". No warranty of any kind is made by TxDOT for any purpose whatsoever. TxDOT assumes no responsibility for the conversion of this standard to other formats or for incorrect results or damages resulting from its use.

TABLES OF ESTIMATED QUANTITIES WITH 2:1 HEADER SLOPE ⁽¹²⁾

TYPE Tx28 Girders					TYPE Tx34 Girders					TYPE Tx40 Girders					TYPE Tx46 Girders					TYPE Tx54 Girders									
Bar	No.	Size	Length	Weight	Bar	No.	Size	Length	Weight	Bar	No.	Size	Length	Weight	Bar	No.	Size	Length	Weight	Bar	No.	Size	Length	Weight					
A	10	#11	45'-0"	2,391	A	10	#11	45'-0"	2,391	A	10	#11	45'-0"	2,391	A	10	#11	45'-0"	2,391	A	10	#11	45'-0"	2,391					
D ⁽⁷⁾	2	#9	1'-8"	11	D ⁽⁷⁾	2	#9	1'-8"	11	D ⁽⁷⁾	2	#9	1'-8"	11	D ⁽⁷⁾	2	#9	1'-8"	11	D ⁽⁷⁾	2	#9	1'-8"	11					
H	8	#6	45'-8"	549	H	8	#6	45'-8"	549	H	10	#6	45'-8"	686	H	10	#6	45'-8"	686	H	12	#6	45'-8"	823					
L	18	#6	4'-0"	108	L	18	#6	4'-0"	108	L	18	#6	4'-0"	108	L	18	#6	4'-0"	108	L	18	#6	4'-0"	108					
S	50	#5	11'-6"	600	S	50	#5	11'-6"	600	S	50	#5	11'-6"	600	S	50	#5	11'-6"	600	S	50	#5	11'-6"	600					
U	4	#6	8'-1"	49	U	4	#6	8'-1"	49	U	4	#6	8'-1"	49	U	4	#6	8'-1"	49	U	4	#6	8'-1"	49					
V	45	#5	11'-4"	532	V	45	#5	12'-4"	579	V	45	#5	13'-4"	626	V	45	#5	14'-4"	673	V	45	#5	15'-8"	735					
wH1	14	#6	9'-5"	198	wH1	14	#6	10'-5"	219	wH1	14	#6	11'-5"	240	wH1	14	#6	12'-5"	261	wH1	14	#6	13'-5"	282					
wH2	20	#6	7'-8"	230	wH2	20	#6	8'-8"	260	wH2	24	#6	9'-8"	348	wH2	24	#6	10'-8"	385	wH2	28	#6	11'-8"	491					
wS	18	#4	7'-10"	94	wS	20	#4	7'-10"	105	wS	22	#4	7'-10"	115	wS	24	#4	7'-10"	126	wS	26	#4	7'-10"	136					
wV	18	#5	11'-4"	213	wV	20	#5	12'-4"	257	wV	22	#5	13'-4"	306	wV	24	#5	14'-4"	359	wV	26	#5	15'-8"	425					
Reinforcing Steel				Lb	4,975	Reinforcing Steel				Lb	5,128	Reinforcing Steel				Lb	5,480	Reinforcing Steel				Lb	5,649	Reinforcing Steel				Lb	6,051
Class "C" Concrete				CY	23.6	Class "C" Concrete				CY	25.4	Class "C" Concrete				CY	27.3	Class "C" Concrete				CY	29.2	Class "C" Concrete				CY	31.7

TABLES OF ESTIMATED QUANTITIES WITH 3:1 HEADER SLOPE ⁽¹²⁾

TYPE Tx28 Girders					TYPE Tx34 Girders					TYPE Tx40 Girders					TYPE Tx46 Girders					TYPE Tx54 Girders									
Bar	No.	Size	Length	Weight	Bar	No.	Size	Length	Weight	Bar	No.	Size	Length	Weight	Bar	No.	Size	Length	Weight	Bar	No.	Size	Length	Weight					
A	10	#11	45'-0"	2,391	A	10	#11	45'-0"	2,391	A	10	#11	45'-0"	2,391	A	10	#11	45'-0"	2,391	A	10	#11	45'-0"	2,391					
D ⁽⁷⁾	2	#9	1'-8"	11	D ⁽⁷⁾	2	#9	1'-8"	11	D ⁽⁷⁾	2	#9	1'-8"	11	D ⁽⁷⁾	2	#9	1'-8"	11	D ⁽⁷⁾	2	#9	1'-8"	11					
H	8	#6	45'-8"	549	H	8	#6	45'-8"	549	H	10	#6	45'-8"	686	H	10	#6	45'-8"	686	H	12	#6	45'-8"	823					
L	18	#6	4'-0"	108	L	18	#6	4'-0"	108	L	18	#6	4'-0"	108	L	18	#6	4'-0"	108	L	18	#6	4'-0"	108					
S	50	#5	11'-6"	600	S	50	#5	11'-6"	600	S	50	#5	11'-6"	600	S	50	#5	11'-6"	600	S	50	#5	11'-6"	600					
U	4	#6	8'-1"	49	U	4	#6	8'-1"	49	U	4	#6	8'-1"	49	U	4	#6	8'-1"	49	U	4	#6	8'-1"	49					
V	45	#5	11'-4"	532	V	45	#5	12'-4"	579	V	45	#5	13'-4"	626	V	45	#5	14'-4"	673	V	45	#5	15'-8"	735					
wH1	14	#6	13'-5"	282	wH1	14	#6	14'-5"	303	wH1	14	#6	16'-5"	345	wH1	14	#6	17'-5"	366	wH1	14	#6	19'-5"	408					
wH2	20	#6	11'-8"	350	wH2	20	#6	12'-8"	381	wH2	24	#6	14'-8"	529	wH2	24	#6	15'-8"	565	wH2	28	#6	17'-8"	743					
wS	26	#4	7'-10"	136	wS	28	#4	7'-10"	147	wS	32	#4	7'-10"	167	wS	34	#4	7'-10"	178	wS	38	#4	7'-10"	199					
wV	26	#5	11'-4"	307	wV	28	#5	12'-4"	360	wV	32	#5	13'-4"	445	wV	34	#5	14'-4"	508	wV	38	#5	15'-8"	621					
Reinforcing Steel				Lb	5,315	Reinforcing Steel				Lb	5,478	Reinforcing Steel				Lb	5,957	Reinforcing Steel				Lb	6,135	Reinforcing Steel				Lb	6,688
Class "C" Concrete				CY	26.2	Class "C" Concrete				CY	28.1	Class "C" Concrete				CY	30.9	Class "C" Concrete				CY	33.0	Class "C" Concrete				CY	36.5

⁽⁷⁾ Omit Dowels D at end of multi-span unit. Adjust reinforcing steel total accordingly.

⁽¹²⁾ Quantities shown are for one abutment only (with approach slab). With no approach slab, add 1.8 CY Class "C" concrete and 274 lbs reinforcing steel for 4 additional Bars H.

 Texas Department of Transportation		Bridge Division Standard	
<h2 style="margin: 0;">ABUTMENTS</h2> <h3 style="margin: 0;">TYPE TX28 THRU TX54</h3> <h3 style="margin: 0;">PRESTR CONC I-GIRDERS</h3> <h3 style="margin: 0;">44' ROADWAY</h3>			
<h2 style="margin: 0;">AIG-44</h2>			
FILE: IG-AIG4400-23.dgn	DN: TAR	CK: KCM	DW: JTR
©TxDOT August 2017	CONT	SECT	JOB
REVISIONS	COUNTY		SHEET NO.
10-2023 - Stirrup Spa			

DATE: FILE: