

DISCLAIMER: The use of this standard is governed by the "Texas Engineering Practice Act". No warranty of any kind is made by TxDOT for any purpose whatsoever. TxDOT assumes no responsibility for the conversion of this standard to other formats or for incorrect results or damages resulting from its use.

TABLE OF FOUNDATION LOADS

Span Length Ft	Girder Type Tx62	
	Tons/Shaft	Tons/Pile
60	71	62
65	74	63
70	77	65
75	81	67
80	84	69
85	87	70
90	91	72
95	94	74
100	97	75
105	100	77
110	104	79
115	107	80
120	110	82
125	113	84
130	117	85

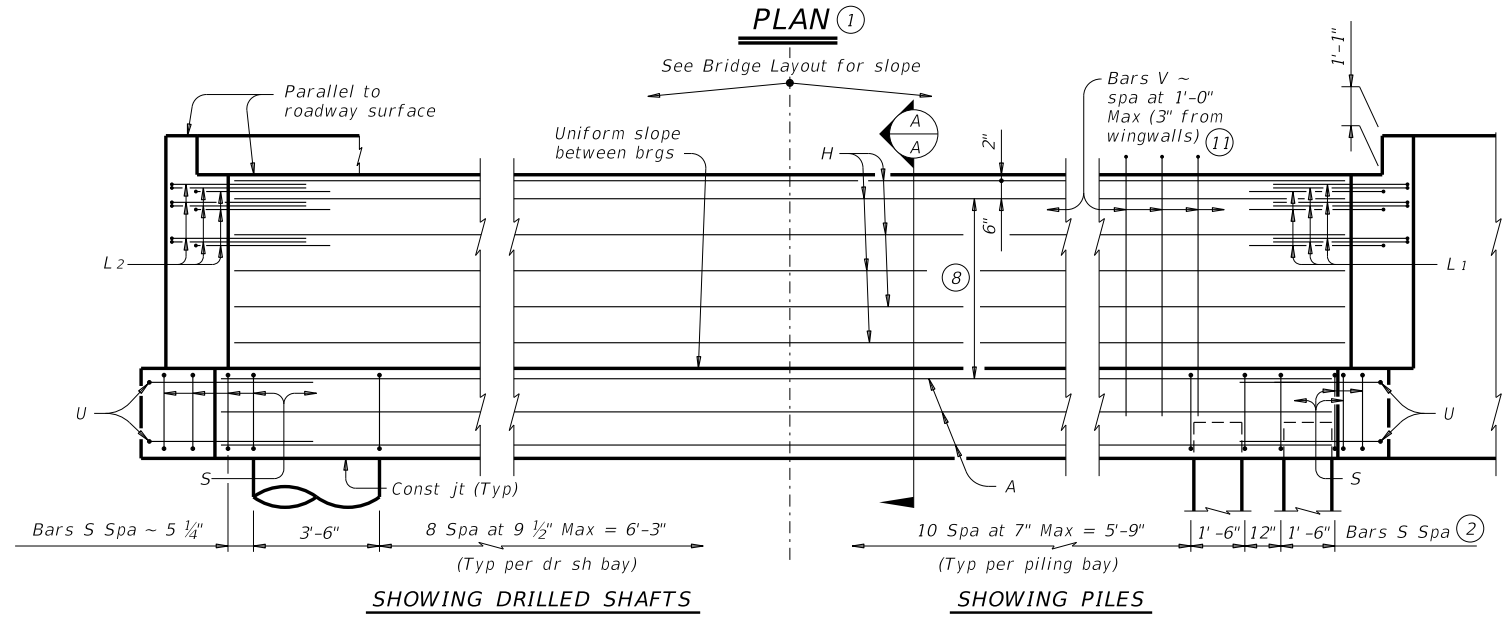
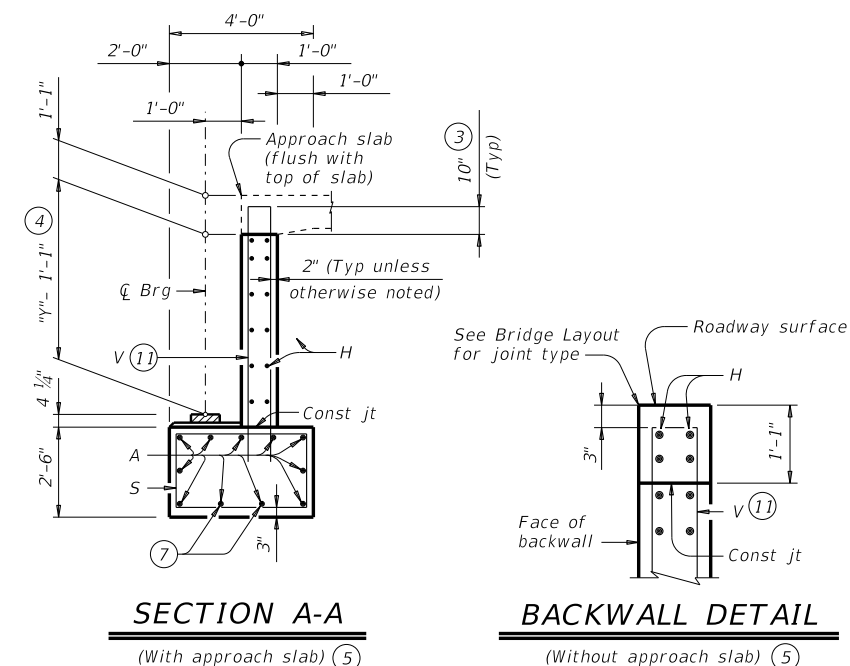
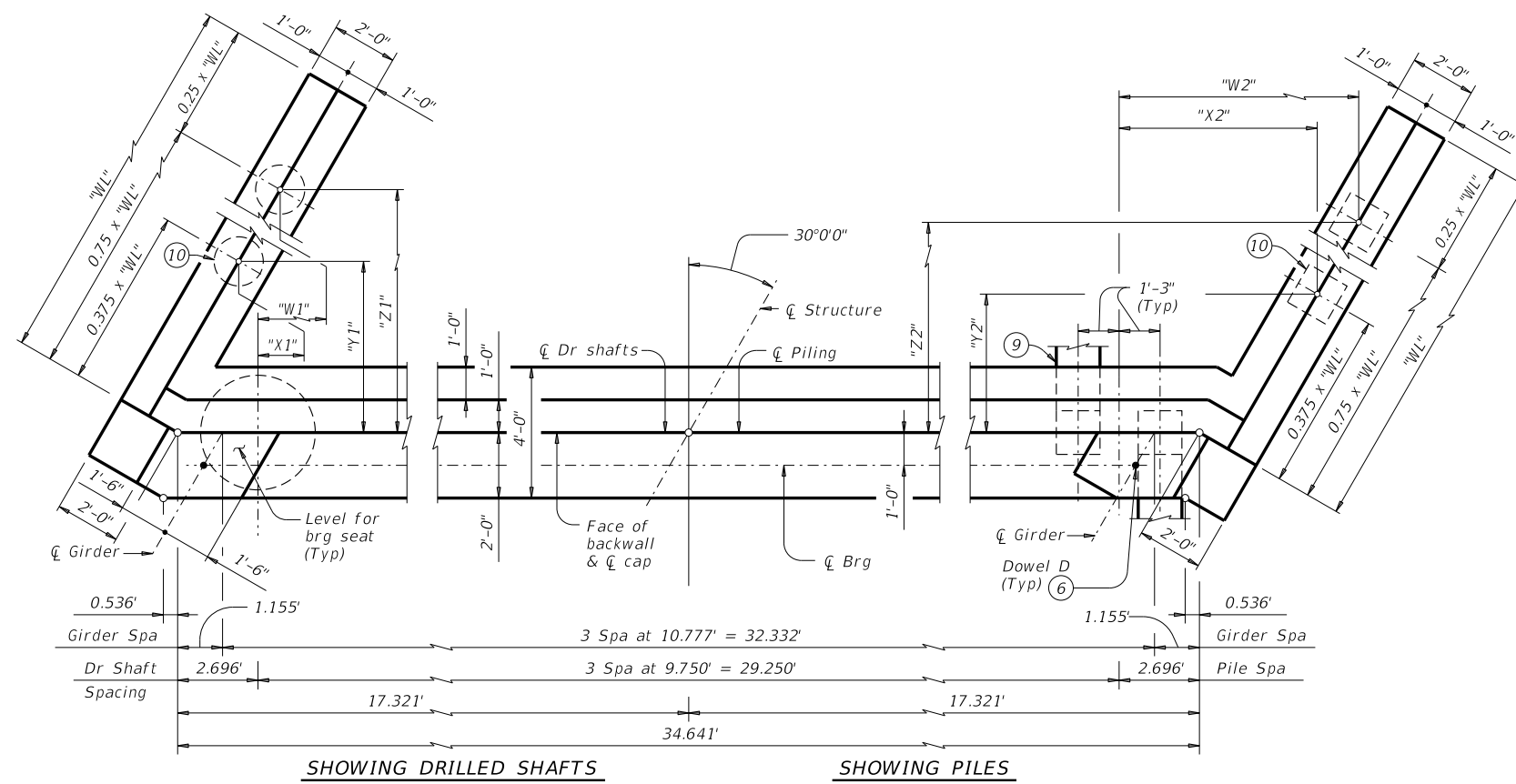

- ① See Table A for variable dimensions based on header slope.
- ② For piling larger than 16" adjust Bars S spacing as required to avoid piling.
- ③ Increase as required to maintain 3" from finished grade.
- ④ See Span details for "Y" value.
- ⑤ See Bridge Layout to determine if approach slab is present.
- ⑥ Omit Dowels D at end of multi-span unit. Adjust reinforcing steel total accordingly.
- ⑦ With pile foundations, move Bars A shown to clear piles.
- ⑧ 5 Spaces at 1'-0" Max.
- ⑨ See Detail A on FD standard.
- ⑩ See Table A to determine if this wingwall foundation is required.
- ⑪ Field bend as needed to clear piles.

GENERAL NOTES:
 Designed according to AASHTO LRFD Bridge Design Specifications.
 See Bridge Layout for header slope and foundation type, size and length.
 See Common Foundation Details (FD) standard sheet for all foundation details and notes.
 See Concrete Riprap (CRR) standard sheet or Stone Riprap (SRR) standard sheet for riprap attachment details, if applicable.
 See applicable rail details for rail anchorage in wingwalls.
 Details are drawn showing right forward skew. See Bridge Layout for actual skew direction.
 These abutment details may be used with standard SIG-62-32-30 only.

Cover dimensions are clear dimensions, unless noted otherwise.
 Reinforcing bar dimensions shown are out-to-out of bar.

MATERIAL NOTES:
 Provide Class C concrete (f'c = 3,600 psi).
 Provide Class C (HPC) concrete if shown elsewhere in the plans.
 Provide Grade 60 reinforcing steel.
 Galvanize dowel bars D.

HL93 LOADING SHEET 1 OF 2



**ABUTMENTS
 TYPE TX62
 PRESTR CONC I-GIRDERS
 32' ROADWAY 30° SKEW
 AIG-62-32-30**

FILE: IG-AIG623230-23.dgn	DN: TAR	CK: KCM	DW: JTR	CK: TAR
©TxDOT August 2017	CONT	SECT	JOB	HIGHWAY
10-2023 - Stirrup Spa	DIST	COUNTY	SHEET NO.	

TABLE A

Header Slope	Girder Type	Wingwall Type	Wingwall Lgth "WL"	"W1"	"X1"	"Y1"	"Z1"	"W2"	"X2"	"Y2"	"Z2"
2:1	Tx62	Founded	17.000'	2.813'	Not Applicable		11.542'	9.937'	Not Applicable		10.542'
3:1	Tx62	Founded	24.000'	5.438'	0.938'	8.294'	16.088'	12.562'	8.062'	7.294'	15.088'

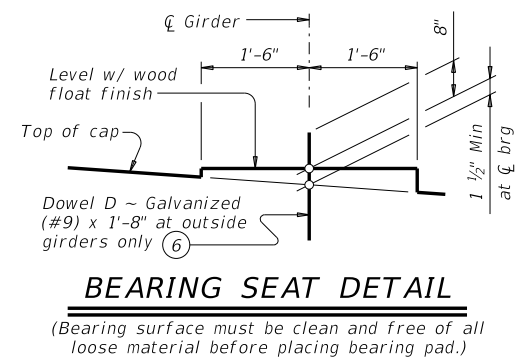

DATE: FILE:

DISCLAIMER: This standard is governed by the "Texas Engineering Practice Act". No warranty of any kind is made by TxDOT for any purpose whatsoever. TxDOT assumes no responsibility for the conversion of this standard to other formats or for incorrect results or damages resulting from its use.

DATE:
FILE:

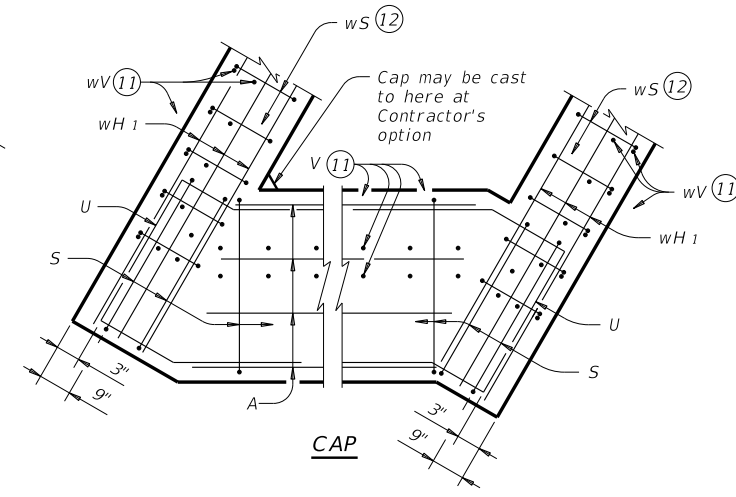
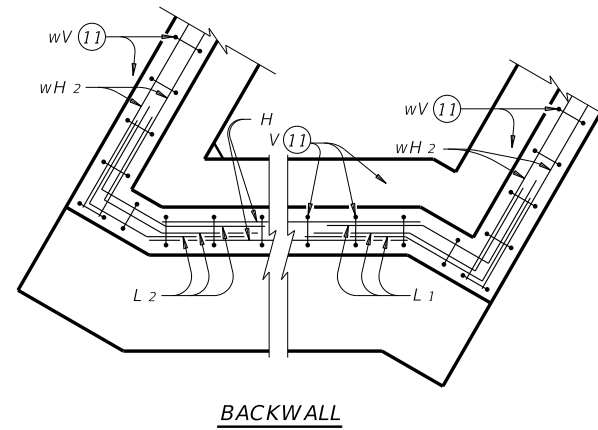
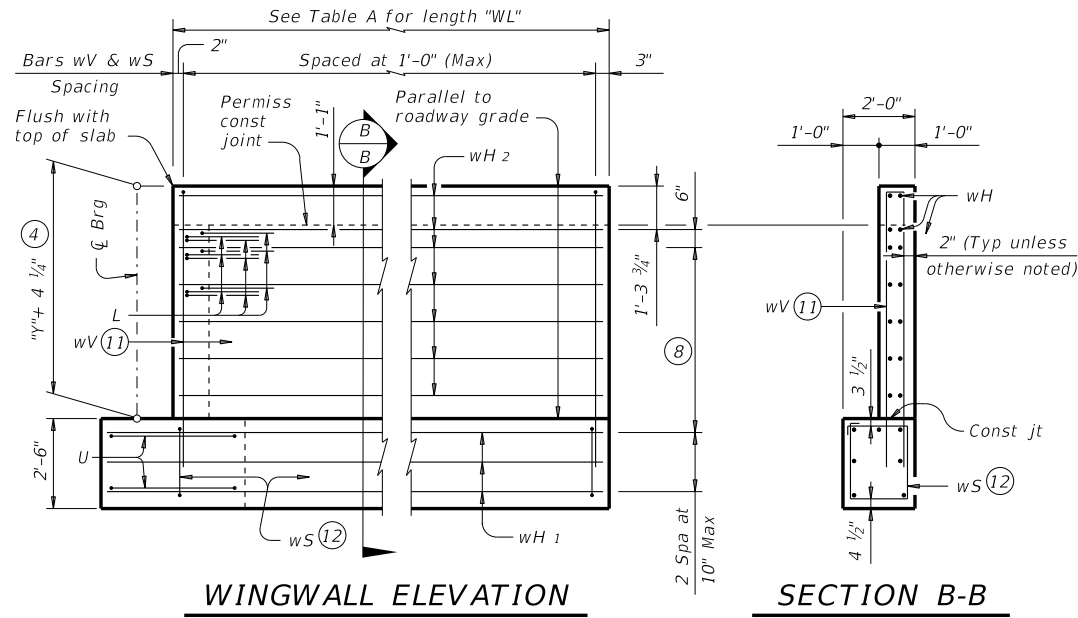

CORNER DETAILS

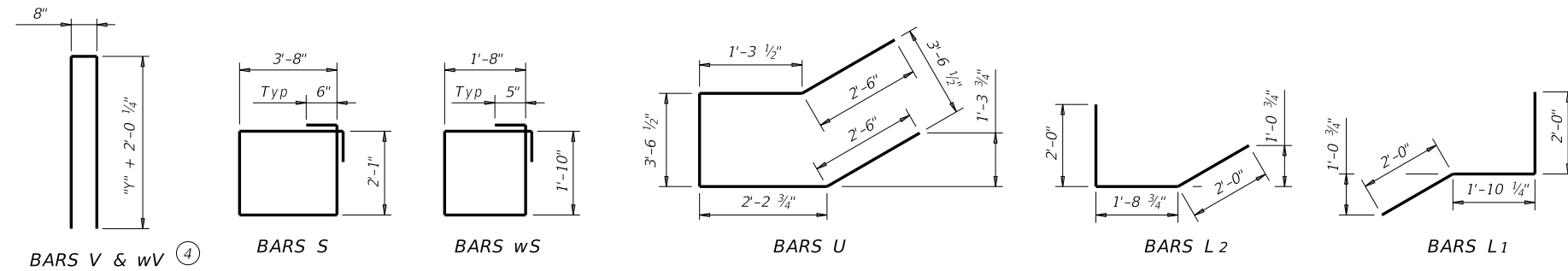

- 4 See Span details for "y" value.
- 6 Omit Dowels D at end of multi-span unit. Adjust reinforcing steel total accordingly.
- 8 5 Spaces at 1'-0" Max.
- 11 Field bend as needed to clear piles.
- 12 Adjust as required to avoid piling.
- 13 Quantities shown are for one abutment only (with approach slab). With no approach slab, add 1.5 CY Class "C" concrete and 208 lbs reinforcing steel for 4 additional Bars H.

TABLE OF ESTIMATED QUANTITIES WITH 2:1 HEADER SLOPE

TYPE Tx62 Girders					
Bar	No.	Size	Length	Weight	
A	11	#11	34'-8"	2,026	
D 6	2	#9	1'-8"	11	
H	12	#6	34'-8"	625	
L1	9	#6	5'-11"	80	
L2	9	#6	5'-9"	78	
S	35	#5	12'-6"	456	
U	4	#6	12'-1"	73	
V	38	#5	17'-0"	674	
wH1	14	#6	18'-8"	393	
wH2	28	#6	16'-8"	701	
wS	36	#4	7'-10"	188	
wV	36	#5	17'-0"	638	
Reinforcing Steel				Lb	5,943
Class "C" Concrete				CY	35.5

TABLE OF ESTIMATED QUANTITIES WITH 3:1 HEADER SLOPE

TYPE Tx62 Girders					
Bar	No.	Size	Length	Weight	
A	11	#11	34'-8"	2,026	
D 6	2	#9	1'-8"	11	
H	12	#6	34'-8"	625	
L1	9	#6	5'-11"	80	
L2	9	#6	5'-9"	78	
S	35	#5	12'-6"	456	
U	4	#6	12'-1"	73	
V	38	#5	17'-0"	674	
wH1	14	#6	25'-8"	540	
wH2	28	#6	23'-8"	995	
wS	50	#4	7'-10"	262	
wV	50	#5	17'-0"	887	
Reinforcing Steel				Lb	6,707
Class "C" Concrete				CY	41.4

Texas Department of Transportation Bridge Division Standard

ABUTMENTS
TYPE TX62
PRESTR CONC I-GIRDERS
32' ROADWAY 30° SKEW

AIG-62-32-30

FILE: IG-AIG623230-23.dgn	DN: TAR	CK: KCM	DW: JTR	CK: TAR
©TxDOT August 2017	CONT	SECT	JOB	HIGHWAY
REVISIONS				
10-2023 - Stirrup Spa	DIST	COUNTY	SHEET NO.	