

DISCLAIMER: The use of this standard is governed by the "Texas Engineering Practice Act". No warranty of any kind is made by TxDOT for any purpose whatsoever. TxDOT assumes no responsibility for the conversion of this standard to other formats or for incorrect results or damages resulting from its use.

DATE: FILE:

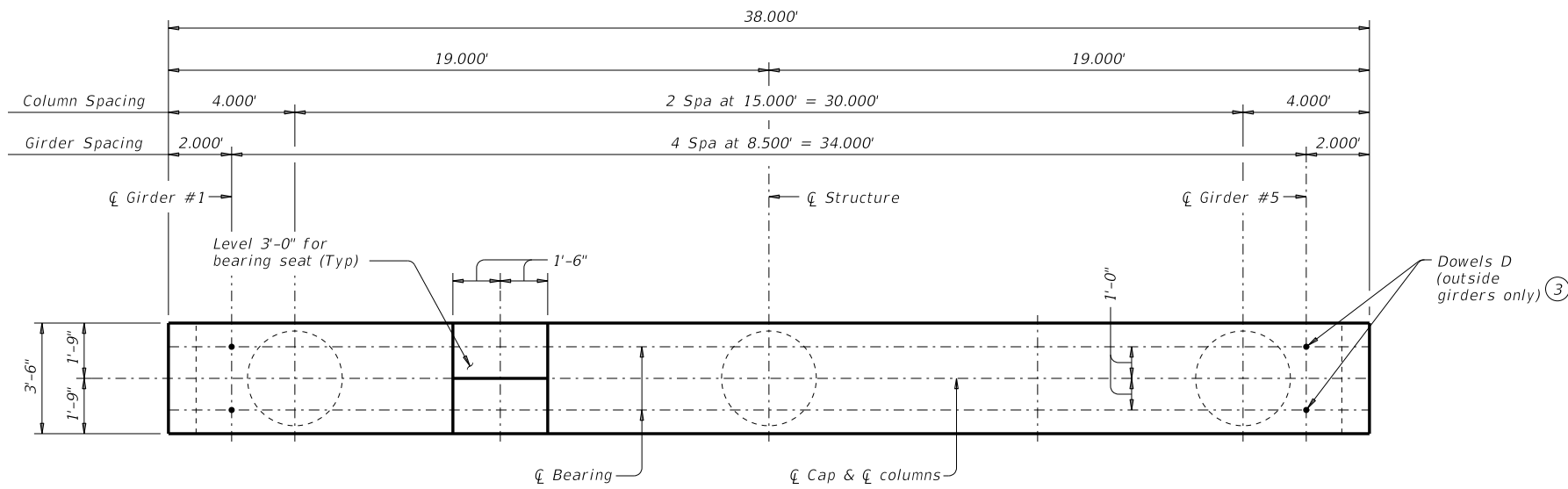

PLAN

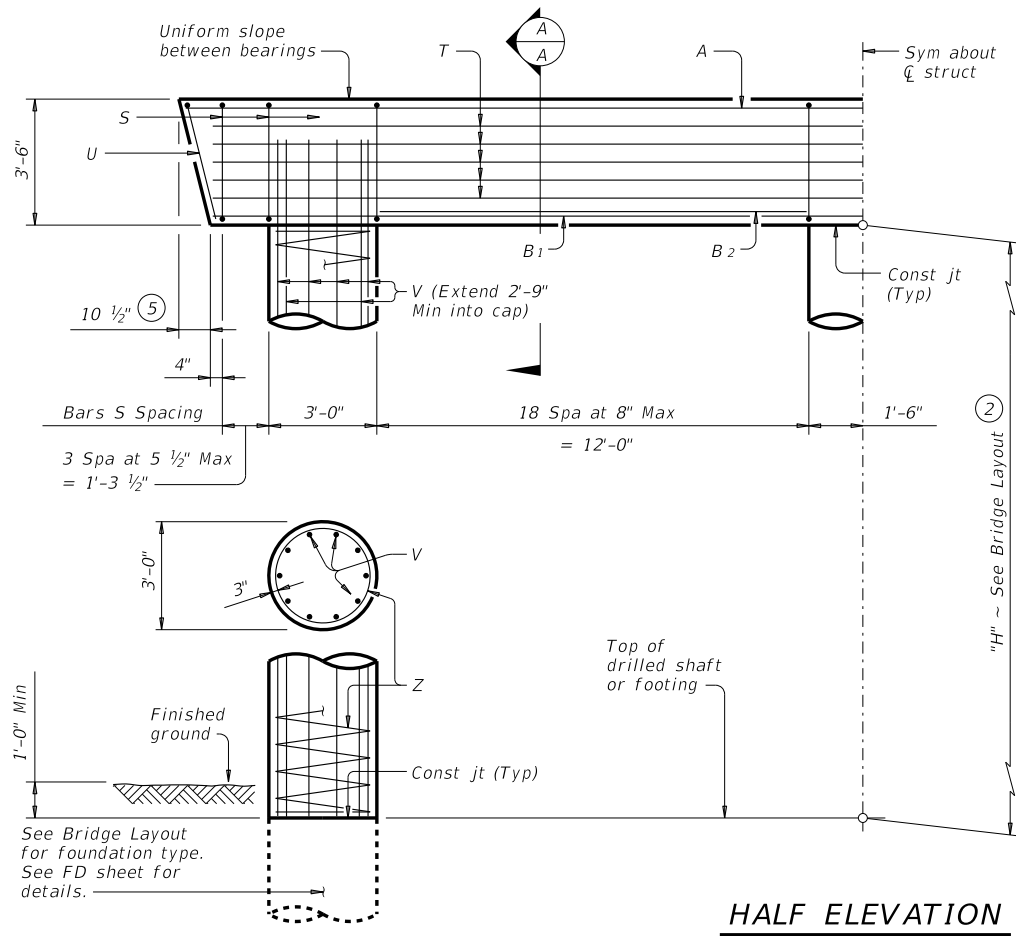

HALF ELEVATION

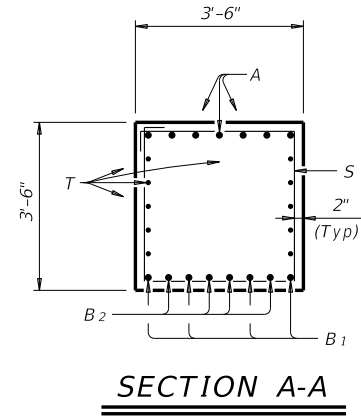

SECTION A-A

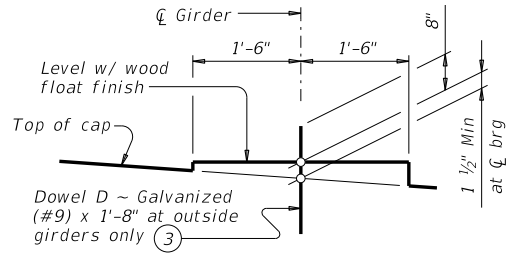

BEARING SEAT DETAIL

(Bearing surface must be clean and free of all loose material before placing bearing pad.)

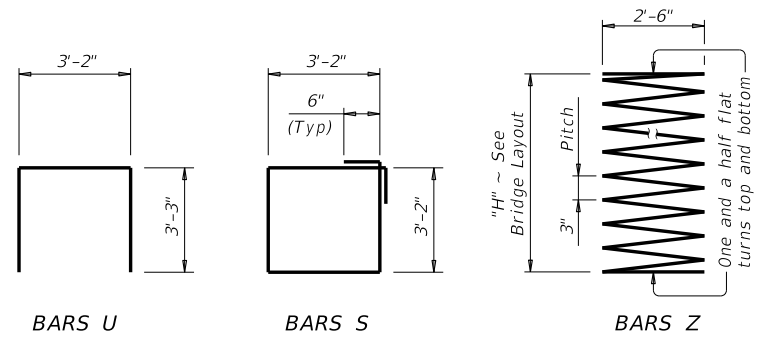

- Quantities shown are based on an "H" value of 36'. For each linear foot variation in "H" value, make the following adjustments:
 Bars V length, 1'-0"
 Bars Z length, 31'-5"
 Reinforcing steel, 165 Lb
 Class "C" conc (col), 0.78 CY
- This standard may not be used for "H" heights exceeding 36'. In areas of very soft soil or where scour is anticipated, allowable "H" heights must be evaluated by the Engineer prior to the use of this standard.
- Omit Dowels D at end of multi-span units. Adjust reinforcing steel total accordingly.
- Foundation Loads based on "H" = 36'.
- Measured parallel to top of cap cross-slope.

TABLE OF ESTIMATED QUANTITIES ①				
Bar	No.	Size	Length	Weight
A	7	#11	37'- 6"	1,395
B ₁	4	#11	36'- 0"	765
B ₂	8	#11	12'-0"	510
D ③	4	#9	1'- 8"	23
S	46	#5	13'- 8"	656
T	10	#5	36'- 0"	375
U	2	#5	9'- 8"	20
V	30	#9	38'- 9"	3,953
Z	3	#4	1154'- 7"	2,314
Reinforcing Steel				Lb 10,011
Class "C" Concrete (Cap)				CY 17.1
Class "C" Concrete (Col)				CY 28.3

FOUNDATION LOADS ④				
Span Average	Drilled Shaft Loads	Pile Load (Tons/Pile)		
		3 Pile Ftg	4 Pile Ftg	5 Pile Ftg
Ft	Tons/Shaft			
40	133	48	36	30
45	143	51	39	32
50	154	55	42	34
55	164	58	44	36
60	174	61	47	38
65	184	65	49	40
70	194	68	52	42
75	204	71	54	44
80	214	75	57	46
85	224	78	59	48
90	234	81	62	50
95	243	84	64	52
100	253	88	66	54
105	263	91	69	56
110	273	94	71	58
115	283	98	74	60
120	293	101	76	62
125	302	104	79	64

GENERAL NOTES:
 Designed according to AASHTO LRFD Bridge Design Specifications.
 See Bridge Layout for foundation type, size and length.
 See Common Foundation Details (FD) standard sheet for all foundation details and notes.
 See Shear Key (IGSK) standard sheet for all shear key details and notes, if applicable.
 Bent selected must be based on the average span length rounded up to the next 5 ft increment.
 These bent details may be used with standard SIG-38 only.

Cover dimensions are clear dimensions, unless noted otherwise. Reinforcing bar dimensions shown are out-to-out of bar.

MATERIAL NOTES:
 Provide Class C concrete (f'c = 3,600 psi).
 Provide Class C (HPC) concrete if shown elsewhere in the plans.
 Provide Grade 60 reinforcing steel.
 Galvanize dowel bars D.

HL93 LOADING

Bridge Division Standard

**INTERIOR BENTS
 TYPE TX28 THRU TX54
 PRESTR CONC I-GIRDERS
 38' ROADWAY**

BIG-38

FILE: IG-BIG3800-17.dgn	DN: TAR	CK: SDB	DW: JTR	CK: TAR
©TxDOT August 2017	CONT	SECT	JOB	HIGHWAY
REVISIONS	DIST	COUNTY	SHEET NO.	