

DISCLAIMER: The use of this standard is governed by the "Texas Engineering Practice Act". No warranty of any kind is made by TxDOT for any purpose whatsoever. TxDOT assumes no responsibility for the conversion of this standard to other formats or for incorrect results or damages resulting from its use.

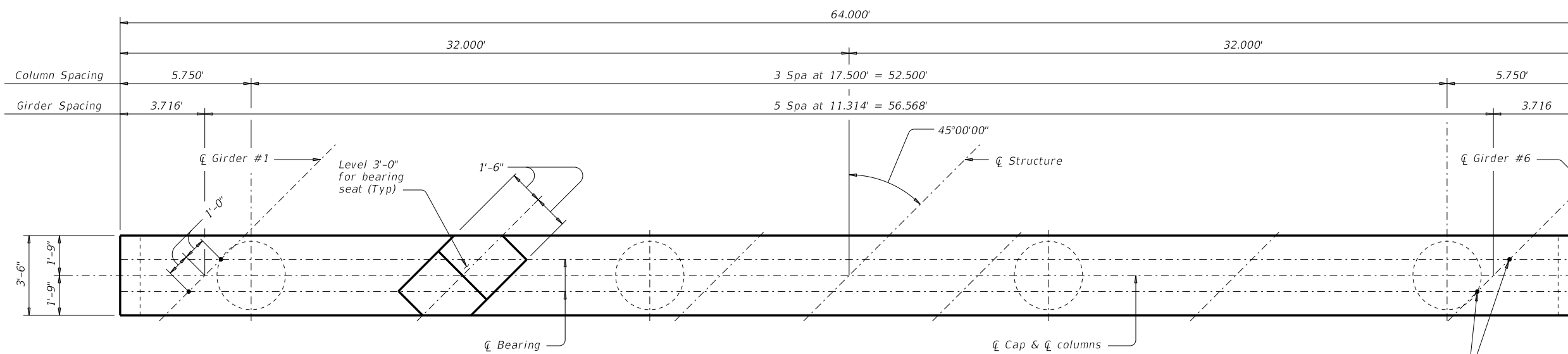

**PLAN**

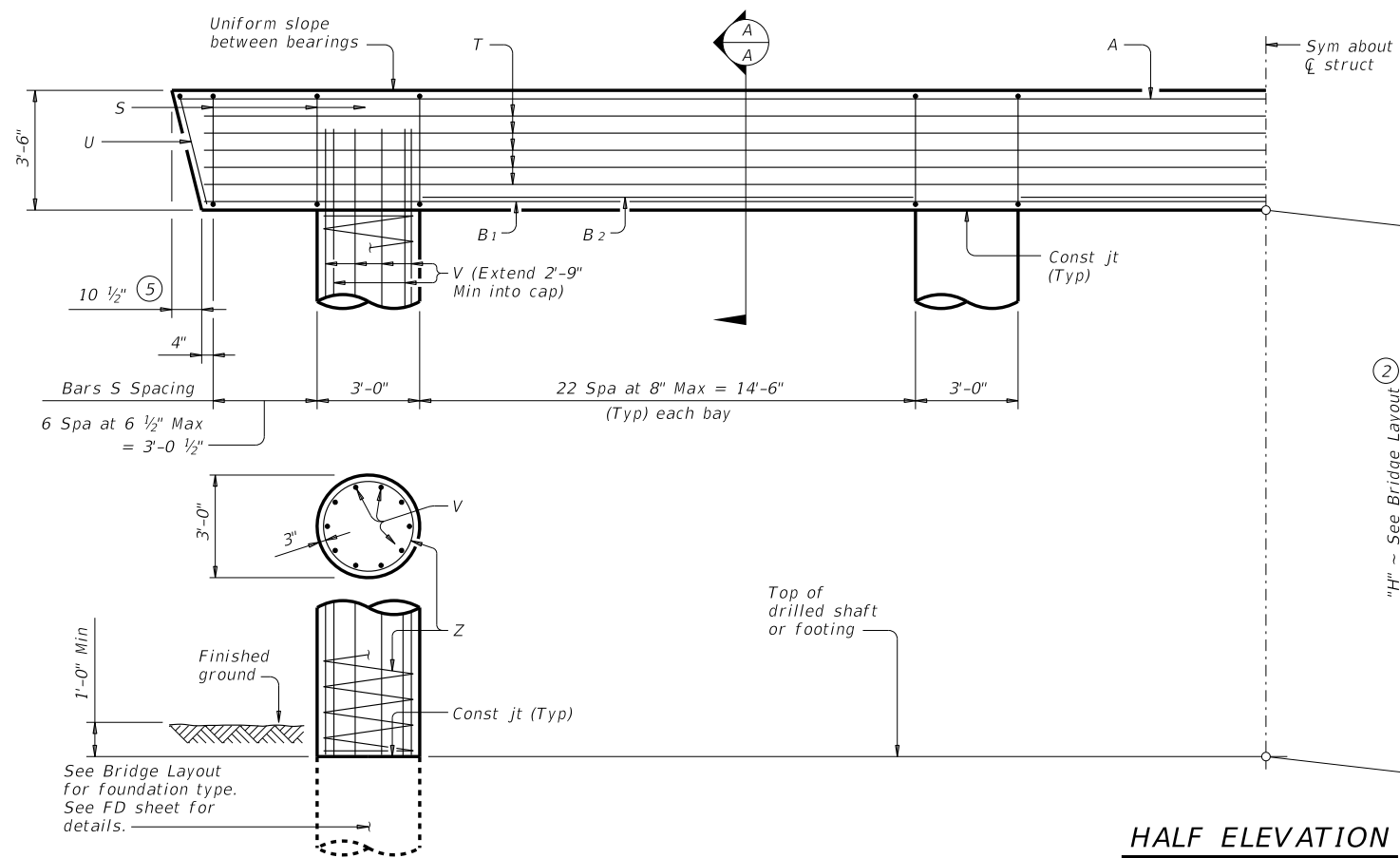

**HALF ELEVATION**

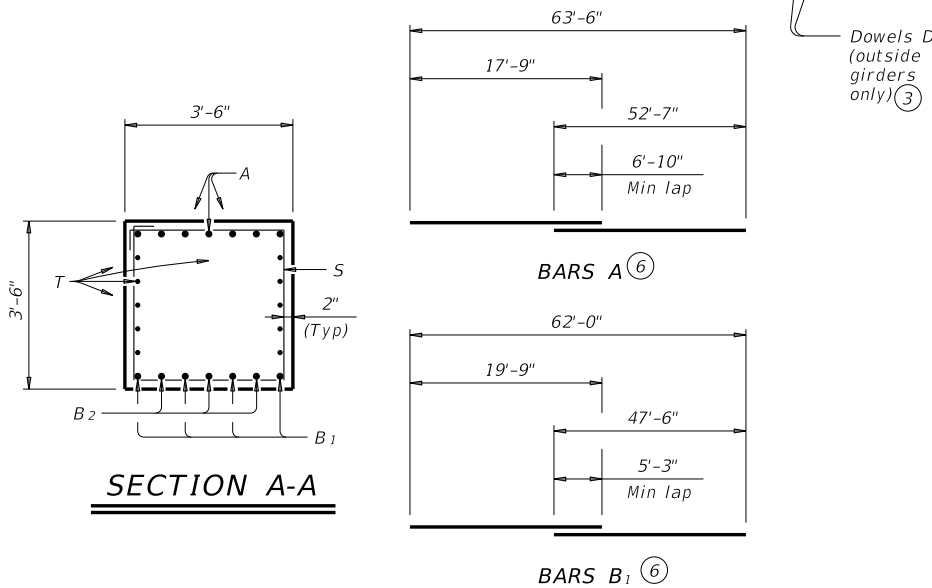

**SECTION A-A**

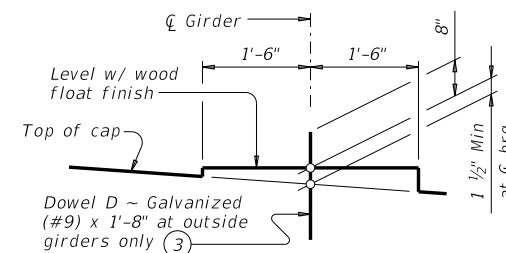

**BEARING SEAT DETAIL**

(Bearing surface must be clean and free of all loose material before placing bearing pad.)

See Bridge Layout for foundation type. See FD sheet for details.

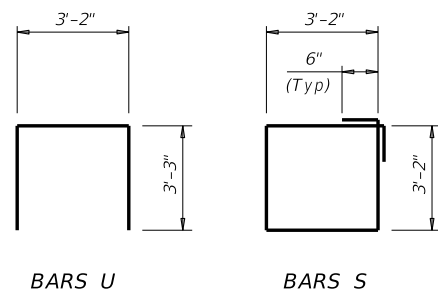

**BARS U**

**BARS S**

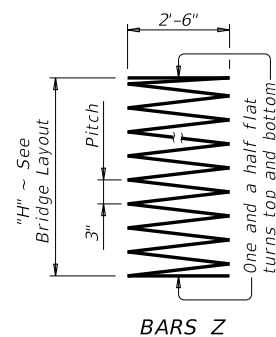

**BARS Z**

**TABLE OF ESTIMATED QUANTITIES (1)**

Bar	No.	Size	Length	Weight	
A	7	#11	70'-4"	2,616	
B <sub>1</sub>	4	#11	67'-3"	1,429	
B <sub>2</sub>	9	#11	14'-6"	694	
D (3)	4	#9	1'-8"	23	
S	83	#5	13'-8"	1,183	
T (7)	10	#5	63'-10"	666	
U	2	#5	9'-8"	20	
V	40	#9	38'-9"	5,270	
Z	4	#4	1,154'-7"	3,085	
Reinforcing Steel				Lb	14,986
Class "C" Concrete (Cap)				CY	29.1
Class "C" Concrete (Col)				CY	37.7

**FOUNDATION LOADS (4)**

Span Average	Drilled Shaft Loads	Pile Load (Tons/Pile)		
		3 Pile Ftg	4 Pile Ftg	5 Pile Ftg
Ft	Tons/Shaft			
40	118	43	33	27
45	127	46	35	29
50	136	49	37	30
55	145	52	39	32
60	153	54	41	34
65	162	57	44	36
70	170	60	46	37
75	179	63	48	39
80	187	66	50	41
85	196	69	52	42
90	204	71	54	44
95	212	74	56	46
100	221	77	58	47
105	229	80	60	49
110	238	83	63	51
115	246	85	65	52
120	254	88	67	54
125	263	91	69	56

**GENERAL NOTES:**

Designed according to AASHTO LRFD Bridge Design Specifications. See Bridge Layout for foundation type, size and length. See Common Foundation Details (FD) standard sheet for all foundation details and notes. See Shear Key (IGSK) standard sheet for all shear key details and notes, if applicable. Bent selected must be based on the average span length rounded up to the next 5 ft increment. Details are drawn showing right forward skew. See Bridge Layout for actual skew direction. These bent details may be used with standard SIG-44-45 only.

Cover dimensions are clear dimensions, unless noted otherwise. Reinforcing bar dimensions shown are out-to-out of bar.

**MATERIAL NOTES:**

Provide Class C concrete (f'c = 3,600 psi). Provide Class C (HPC) concrete if shown elsewhere in the plans. Provide Grade 60 reinforcing steel. Galvanize dowel bars D.

HL93 LOADING



**INTERIOR BENTS**  
**TYPE TX28 THRU TX54**  
**PRESTR CONC I-GIRDERS**  
**44' ROADWAY 45° SKEW**

**BIG-44-45**

FILE: IG-BIG4445-17.dgn	DN: TAR	CK: SDB	DW: JTR	CK: TAR
©TxDOT August 2017	CONT	SECT	JOB	HIGHWAY
REVISIONS	DIST	COUNTY	SHEET NO.	

- Quantities shown are based on an "H" value of 36'. For each linear foot variation in "H" value, make the following adjustments:  
 Bars V length, 1'-0"  
 Bars Z length, 31'-5"  
 Reinforcing steel, 220 Lb  
 Class "C" conc (col), 1.0 CY
- This standard may not be used for "H" heights exceeding 36'. In areas of very soft soil or where scour is anticipated, allowable "H" heights must be evaluated by the Engineer prior to the use of this standard.
- Omit Dowels D at end of multi-span units. Adjust reinforcing steel total accordingly.
- Foundation Loads based on "H" = 36'.
- Measured parallel to top of cap cross-slope.
- Alternate lap location between adjacent bars.
- Includes one 1'-10" Min lap.

DATE: FILE: