

DISCLAIMER: The use of this standard is governed by the "Texas Engineering Practice Act". No warranty of any kind is made by TxDOT for any purpose whatsoever. TxDOT assumes no responsibility for the conversion of this standard to other formats or for incorrect results or damages resulting from its use.

DATE: FILE:

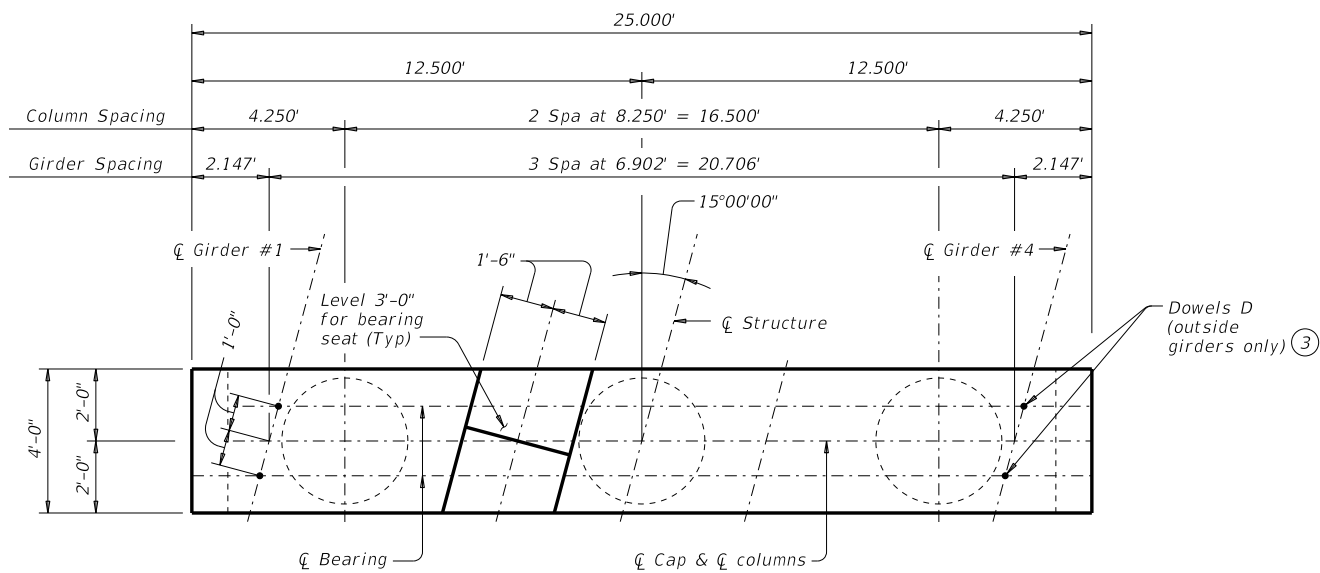

PLAN

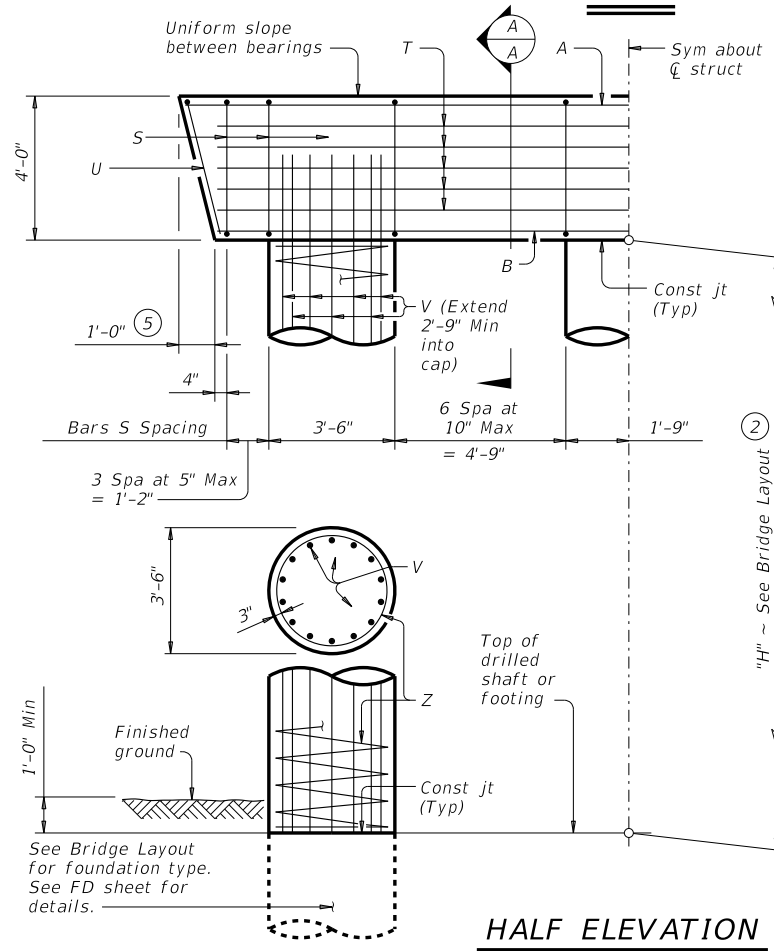

HALF ELEVATION

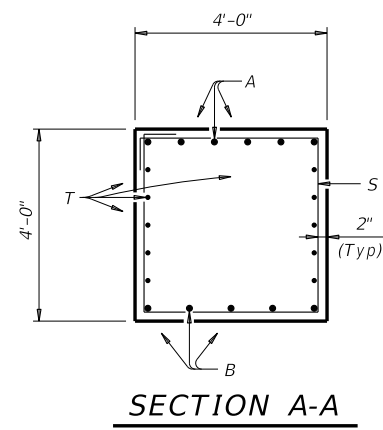

SECTION A-A

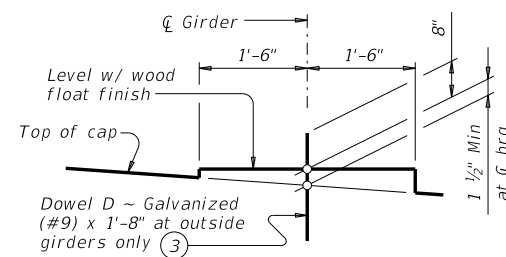

BEARING SEAT DETAIL

(Bearing surface must be clean and free of all loose material before placing bearing pad.)

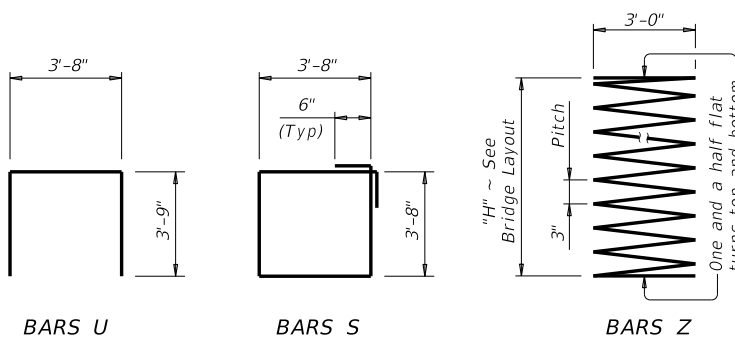

- ① Quantities shown are based on an "H" value of 36'. For each linear foot variation in "H" value, make the following adjustments:
 Bars V length, 1'-0"
 Bars Z length, 37'-9"
 Reinforcing steel, 219 Lb
 Class "C" conc (col), 1.07 CY
- ② This standard may not be used for "H" heights exceeding 36'. In areas of very soft soil or where scour is anticipated, allowable "H" heights must be evaluated by the Engineer prior to the use of this standard.
- ③ Omit Dowels D at end of multi-span units. Adjust reinforcing steel total accordingly.
- ④ Foundation Loads based on "H" = 36'.
- ⑤ Measured parallel to top of cap cross-slope.

TABLE OF ESTIMATED QUANTITIES ①

Bar	No.	Size	Length	Weight
A	6	#11	24'- 6"	781
B	5	#11	22'- 9"	604
D ③	4	#9	1'- 8"	23
S	22	#5	15'- 8"	359
T	10	#5	22'- 9"	237
U	2	#5	11'- 2"	23
V	42	#9	38'- 9"	5,534
Z	3	#4	1,387'- 3"	2,780
Reinforcing Steel			Lb	10,341
Class "C" Concrete (Cap)			CY	14.5
Class "C" Concrete (Col)			CY	38.5

FOUNDATION LOADS ④

Span Average	Drilled Shaft Loads	Pile Load (Tons/Pile)	
		Tons/Shaft	4 Pile Ftg
Ft			
60	148		40
65	156		42
70	164		44
75	171		46
80	179		48
85	187		50
90	195		52
95	202		54
100	210		56
105	218		58
110	226		60
115	233		61
120	241		63
125	249		65
130	256		67
135	264		69

GENERAL NOTES:

Designed according to AASHTO LRFD Bridge Design Specifications. See Bridge Layout for foundation type, size and length. See Common Foundation Details (FD) standard sheet for all foundation details and notes. See Shear Key (IGSK) standard sheet for all shear key details and notes, if applicable. Bent selected must be based on the average span length rounded up to the next 5 ft increment. Details are drawn showing right forward skew. See Bridge Layout for actual skew direction. These bent details may be used with standard SIG-62-24-15 only.

Cover dimensions are clear dimensions, unless noted otherwise. Reinforcing bar dimensions shown are out-to-out of bar.

MATERIAL NOTES:

Provide Class C concrete (f'c = 3,600 psi). Provide Class C (HPC) concrete if shown elsewhere in the plans. Provide Grade 60 reinforcing steel. Galvanize dowel bars D.

HL93 LOADING

		Bridge Division Standard	
INTERIOR BENTS TYPE TX62 PRESTR CONC I-GIRDERS 24' ROADWAY 15° SKEW BIG-62-24-15			
FILE: IG-BIG622415-17.dgn	DN: TAR	CK: SDB	DW: JTR
©TxDOT August 2017	CONT	SECT	JOB
REVISIONS	COUNTY		SHEET NO.