

DISCLAIMER: This standard is governed by the "Texas Engineering Practice Act". No warranty of any kind is made by TxDOT for any purpose whatsoever. TxDOT assumes no responsibility for the conversion of this standard to other formats or for incorrect results or damages resulting from its use.

DATE: FILE:

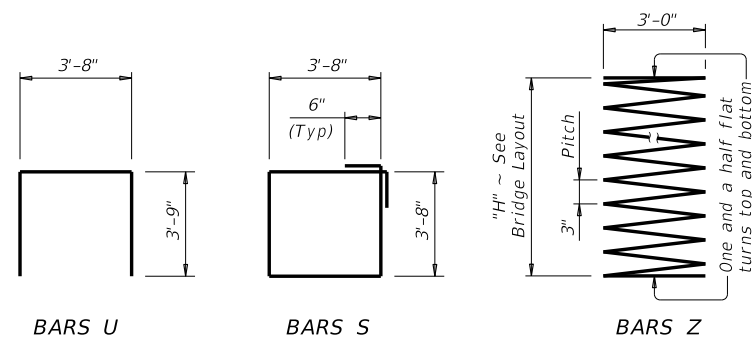
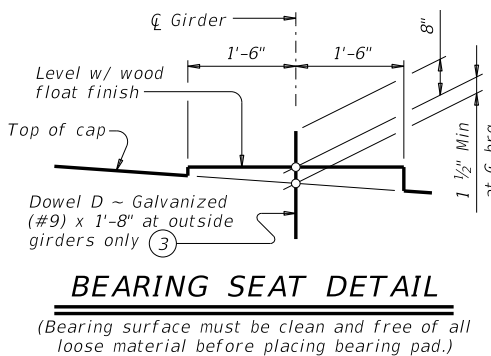
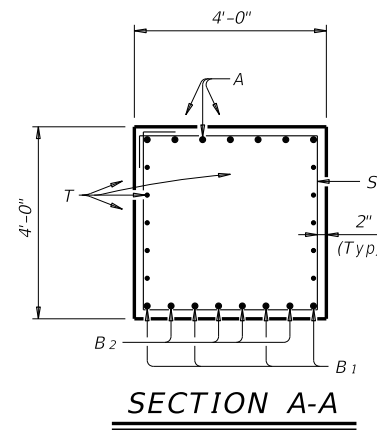
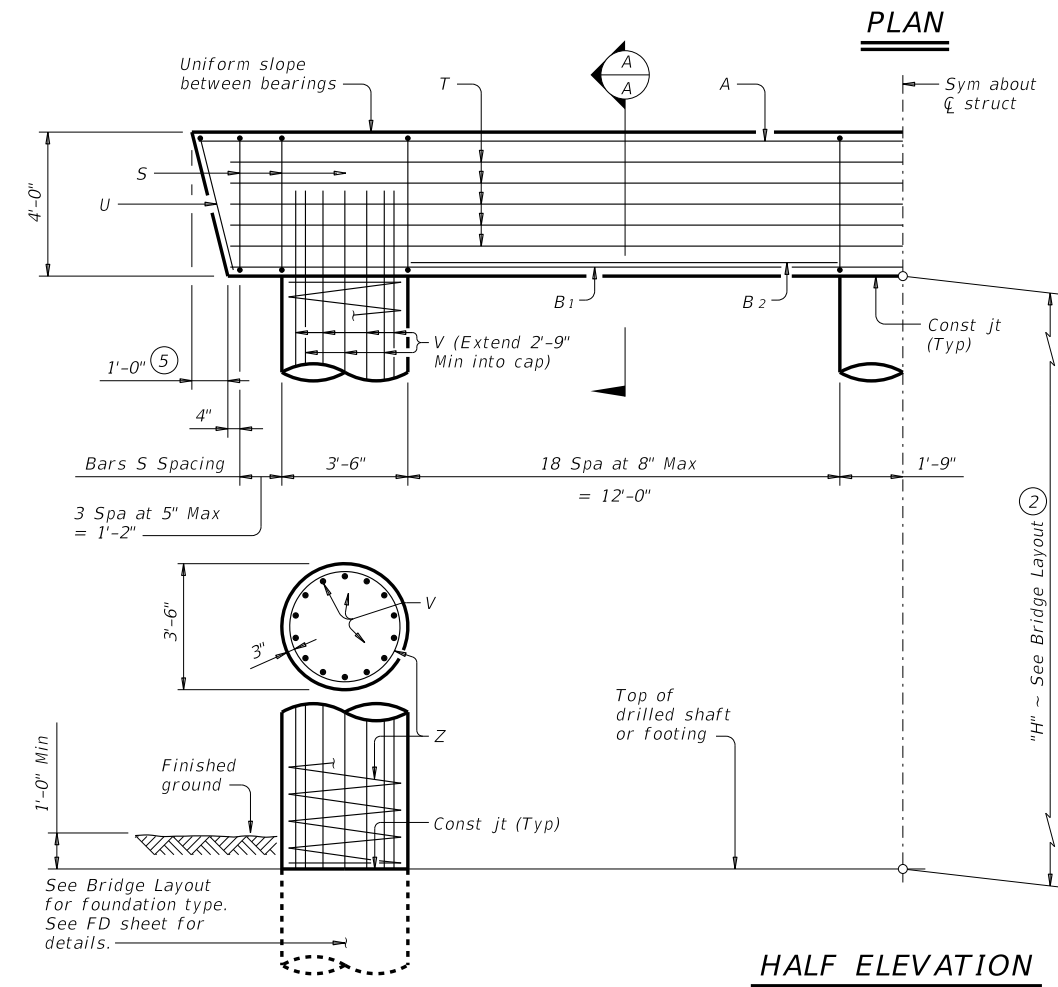
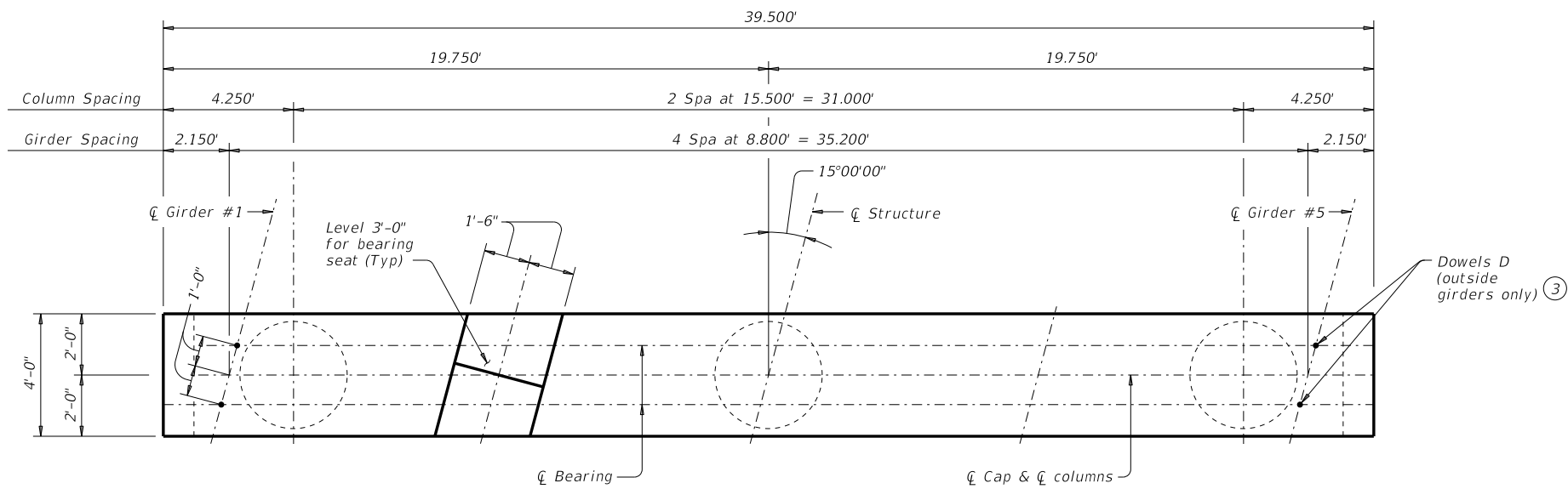

- Quantities shown are based on an "H" value of 36'. For each linear foot variation in "H" value, make the following adjustments:  
 Bars V length, 1'-0"  
 Bars Z length, 37'-9"  
 Reinforcing steel, 219 Lb  
 Class "C" conc (col), 1.07 CY
- This standard may not be used for "H" heights exceeding 36'. In areas of very soft soil or where scour is anticipated, allowable "H" heights must be evaluated by the Engineer prior to the use of this standard.
- Omit Dowels D at end of multi-span units. Adjust reinforcing steel total accordingly.
- Foundation Loads based on "H" = 36'.
- Measured parallel to top of cap cross-slope.

TABLE OF ESTIMATED QUANTITIES ①				
Bar	No.	Size	Length	Weight
A	7	#11	39'- 0"	1,450
B 1	4	#11	37'- 3"	792
B 2	8	#11	12'-0"	510
D ③	4	#9	1'-8"	23
S	46	#5	15'- 8"	752
T	10	#5	37'- 3"	389
U	2	#5	11'- 2"	23
V	42	#9	38'- 9"	5,534
Z	3	#4	1,387'- 3"	2,780
Reinforcing Steel			Lb	12,253
Class "C" Concrete (Cap)			CY	23.1
Class "C" Concrete (Col)			CY	38.5

FOUNDATION LOADS ④			
Span Average	Drilled Shaft Loads	Pile Load (Tons/Pile)	
		4 Pile Ftg	5 Pile Ftg
Ft	Tons/Shaft		
60	190	51	41
65	200	53	43
70	211	56	45
75	221	58	47
80	231	61	49
85	242	64	52
90	252	66	54
95	262	69	56
100	273	71	58
105	283	74	60
110	293	76	62
115	303	79	64
120	314	82	66
125	324	84	68
130	334	87	70
135	344	89	72

**GENERAL NOTES:**  
 Designed according to AASHTO LRFD Bridge Design Specifications. See Bridge Layout for foundation type, size and length. See Common Foundation Details (FD) standard sheet for all foundation details and notes. See Shear Key (IGSK) standard sheet for all shear key details and notes, if applicable. Bent selected must be based on the average span length rounded up to the next 5 ft increment. Details are drawn showing right forward skew. See Bridge Layout for actual skew direction. These bent details may be used with standard SIG-62-38-15 only.

Cover dimensions are clear dimensions, unless noted otherwise. Reinforcing bar dimensions shown are out-to-out of bar.

**MATERIAL NOTES:**  
 Provide Class C concrete (f'c = 3,600 psi). Provide Class C (HPC) concrete if shown elsewhere in the plans. Provide Grade 60 reinforcing steel. Galvanize dowel bars D.

HL93 LOADING

Texas Department of Transportation  
 Bridge Division Standard

**INTERIOR BENTS  
 TYPE TX62  
 PRESTR CONC I-GIRDERS  
 38' ROADWAY 15° SKEW**

**BIG-62-38-15**

FILE: IG-BIG623815-17.dgn	DN: TAR	CK: SDB	DW: JTR	CK: TAR
©TxDOT August 2017	CONT	SECT	JOB	HIGHWAY
REVISIONS	DIST	COUNTY	SHEET NO.	