

DISCLAIMER: This standard is governed by the "Texas Engineering Practice Act". No warranty of any kind is made by TxDOT for any purpose whatsoever. TxDOT assumes no responsibility for the conversion of this standard to other formats or for incorrect results or damages resulting from its use.

DATE: FILE:

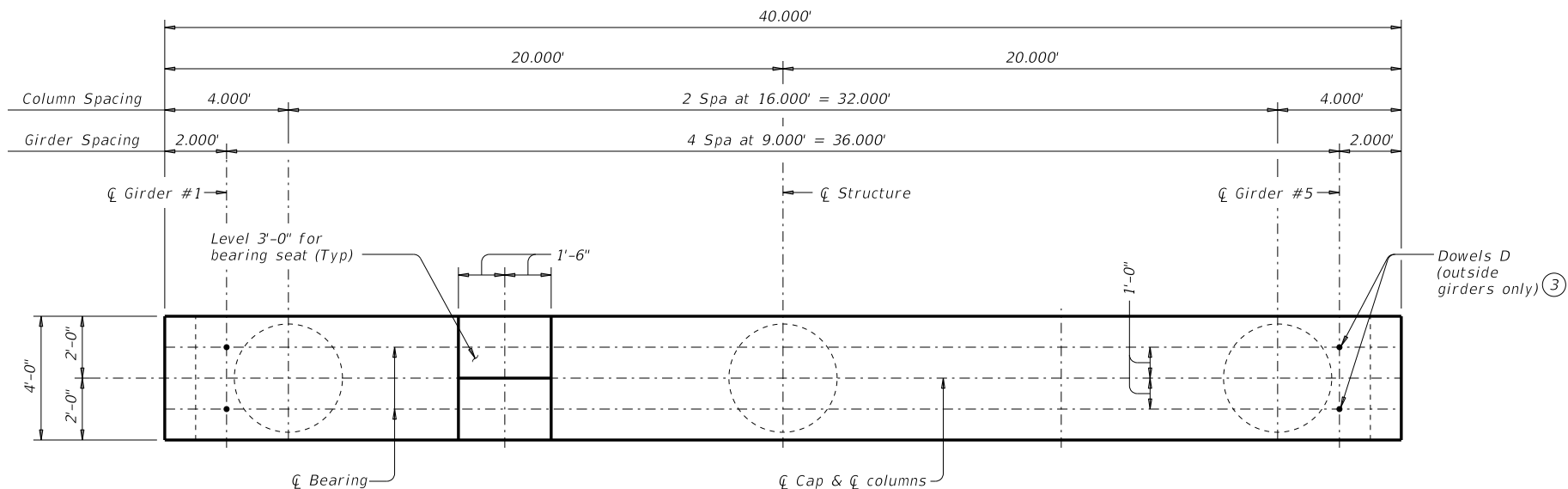

PLAN

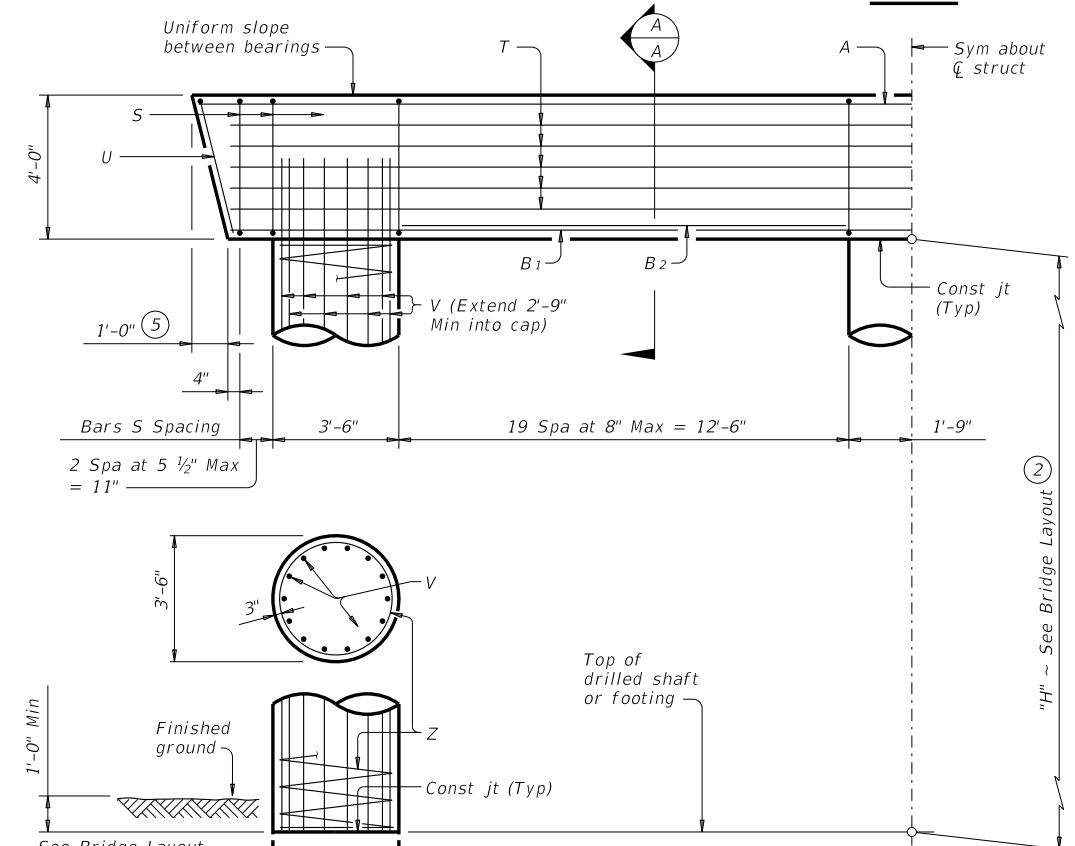

HALF ELEVATION

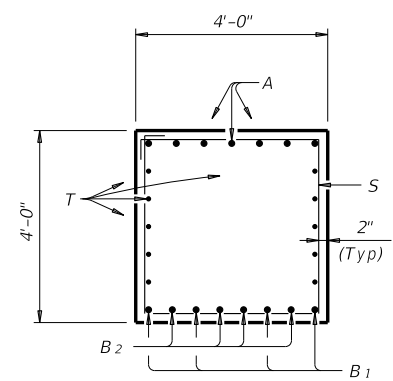

SECTION A-A

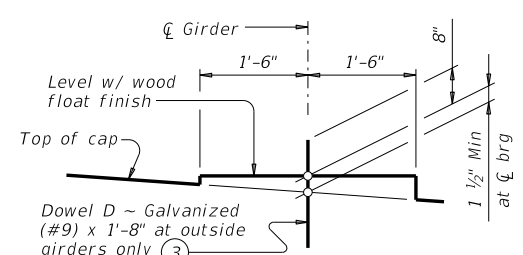

BEARING SEAT DETAIL

(Bearing surface must be clean and free of all loose material before placing bearing pad.)

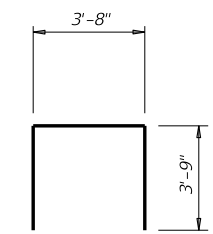

BARS U

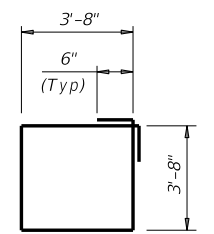

BARS S

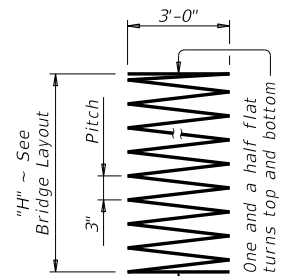

BARS Z

- ① Quantities shown are based on an "H" value of 36'. For each linear foot variation in "H" value, make the following adjustments:
 Bars V length, 1'-0"
 Bars Z length, 37'-9"
 Reinforcing steel, 219 Lb
 Class "C" conc (col), 1.07 CY
- ② This standard may not be used for "H" heights exceeding 36'. In areas of very soft soil or where scour is anticipated, allowable "H" heights must be evaluated by the Engineer prior to the use of this standard.
- ③ Omit Dowels D at end of multi-span units. Adjust reinforcing steel total accordingly.
- ④ Foundation Loads based on "H" = 36'.
- ⑤ Measured parallel to top of cap cross-slope.

TABLE OF ESTIMATED QUANTITIES ①				
Bar	No.	Size	Length	Weight
A	7	#11	39'- 6"	1,469
B ₁	4	#11	37'- 9"	802
B ₂	8	#11	12'- 6"	531
D ③	4	#9	1'-8"	23
S	46	#5	15'- 8"	752
T	10	#5	37'- 9"	394
U	2	#5	11'- 2"	23
V	42	#9	38'- 9"	5,534
Z	3	#4	1,387'- 3"	2,780
Reinforcing Steel			Lb	12,308
Class "C" Concrete (Cap)			CY	23.4
Class "C" Concrete (Col)			CY	38.5

FOUNDATION LOADS ④			
Span Average	Drilled Shaft Loads	Pile Load (Tons/Pile)	
		4 Pile Ftg	5 Pile Ftg
Ft	Tons/Shaft		
60	192	51	42
65	203	54	44
70	214	57	46
75	224	59	48
80	235	62	50
85	245	64	52
90	256	67	54
95	266	70	56
100	277	72	59
105	287	75	61
110	298	78	63
115	308	80	65
120	319	83	67
125	329	85	69
130	340	88	71

GENERAL NOTES:
 Designed according to AASHTO LRFD Bridge Design Specifications. See Bridge Layout for foundation type, size and length. See Common Foundation Details (FD) standard sheet for all foundation details and notes. See Shear Key (IGSK) standard sheet for all shear key details and notes, if applicable. Bent selected must be based on the average span length rounded up to the next 5 ft increment. These bent details may be used with standard SIG-62-40 only.

Cover dimensions are clear dimensions, unless noted otherwise. Reinforcing bar dimensions shown are out-to-out of bar.

MATERIAL NOTES:
 Provide Class C concrete (f'c = 3,600 psi). Provide Class C (HPC) concrete if shown elsewhere in the plans. Provide Grade 60 reinforcing steel. Galvanize dowel bars D.

HL93 LOADING

Texas Department of Transportation
 Bridge Division Standard

**INTERIOR BENTS
 TYPE TX62
 PRESTR CONC I-GIRDERS
 40' ROADWAY**

BIG-62-40

FILE: IG-BIG624000-17.dgn	DN: TAR	CK: SDB	DW: JTR	CK: TAR
©TxDOT August 2017	CONT	SECT	JOB	HIGHWAY
REVISIONS	DIST	COUNTY	SHEET NO.	