

DISCLAIMER: This standard is governed by the "Texas Engineering Practice Act". No warranty of any kind is made by TxDOT for any purpose whatsoever. TxDOT assumes no responsibility for the conversion of this standard to other formats or for incorrect results or damages resulting from its use.

DATE: FILE:

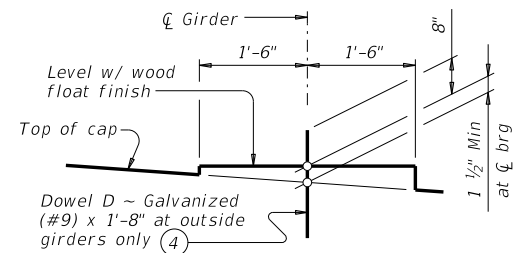

BEARING SEAT DETAIL

(Bearing surface must be clean and free of all loose material before placing bearing pad.)

TABLE OF MAXIMUM ALLOWABLE EXPOSED PILE HEIGHTS AND PILE LOADS (2)

Pile Type		Max Ht	Max Load
Concrete	Steel	Ft	Tons/Pile
18" Sq	HP14x117 (5)	20	90
20" Sq	HP18x135	24	110
24" Sq	(3)	24	140

FOUNDATION LOADS

Span Average	Minimum Concrete Pile Size	Tx28, Tx34 & Tx40 GIRDERS	Tx46 & Tx54 GIRDERS
		Pile Loads	Pile Loads
Ft	In.	(Tons/Pile)	(Tons/Pile)
40	18	64	67
45		69	73
50		75	79
55	20	81	85
60		86	91
65		92	97
70	24	97	103
75		103	109
80		108	115
85		114	121

TABLE OF ESTIMATED QUANTITIES

40' THRU 85' SPANS

Bar	No.	Size	Length	Weight
A	8	#9	27'- 8"	753
D (4)	4	#9	1'- 8"	23
S	28	#5	13'- 8"	399
T	4	#5	27'- 8"	115
Reinforcing Steel			Lb	1,290
Class "C" Concrete			CY	12.9

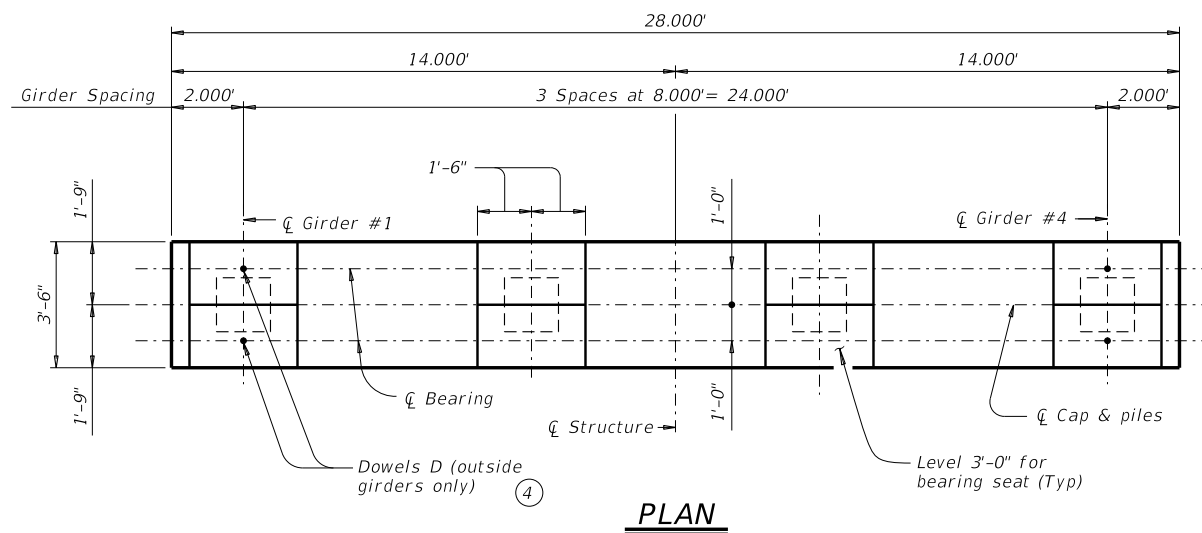

PLAN

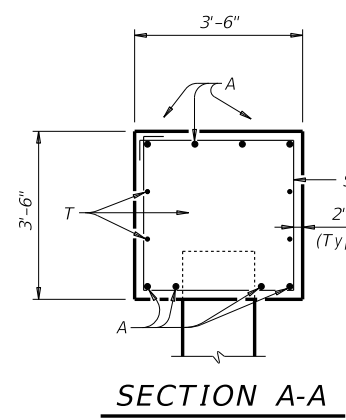

SECTION A-A

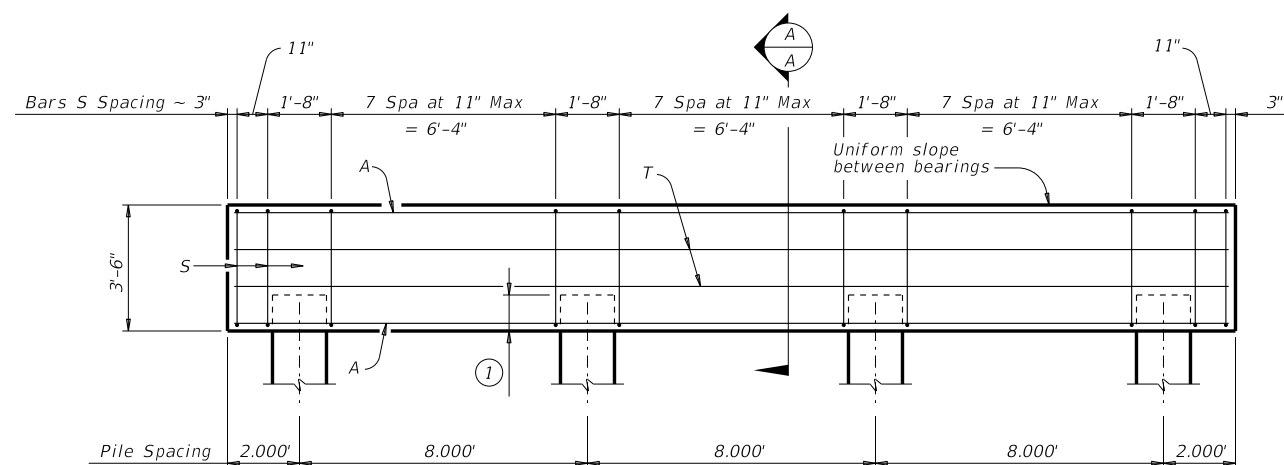

ELEVATION

Note: For piling larger than 18", adjust Bars S as required to avoid piling.

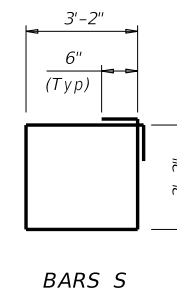

BARS S

- (1) See FD standard.
- (2) In areas of very soft soil or where scour is anticipated, maximum allowable exposed pile heights must be evaluated by the Engineer prior to use of this standard.
- (3) Where no steel HP section is shown, a suitable HP equivalent to the square concrete pile has not been evaluated.
- (4) Omit dowels at end of multi-span units. Adjust reinforcing steel total accordingly.
- (5) When HP14x117 steel piling is specified in the plans, the Contractor has the option of furnishing either HP14x117 or HP16x101 steel piling.

GENERAL NOTES:

Designed according to AASHTO LRFD Bridge Design Specifications. For Bents supporting unequal spans, the shorter span cannot be less than 80 percent of the longer span. These details are limited to an 85' maximum span length. See Bridge Layout for piling size and length. See Common Foundation Details (FD) standard sheet for all foundation details and notes. Bent selected must be based on the average span length rounded up to the next 5 ft increment. These bent details may be used with standard SIG-28 only.

Cover dimensions are clear dimensions, unless noted otherwise. Reinforcing bar dimensions shown are out-to-out of bar.

MATERIAL NOTES:

Provide Class C concrete (f'c = 3,600 psi). Provide Class C (HPC) concrete if shown elsewhere in the plans. Provide Grade 60 reinforcing steel. Galvanize dowel bars D.

HL93 LOADING



INTERIOR TRESTLE BENTS
 TY TX28 THRU TX54
 PRESTR CONC I-GIRDERS
 28' ROADWAY

BTIG-28

FILE: IG-BTIG2800-17.dgn	DN: TAR	CK: SDB	DW: JTR	CK: TAR
©TxDOT August 2017	CONT	SECT	JOB	HIGHWAY
REVISIONS				
DIST	COUNTY			SHEET NO.