

DISCLAIMER: The use of this standard is governed by the "Texas Engineering Practice Act." No warranty of any kind is made by TxDOT for any purpose whatsoever. TxDOT assumes no responsibility for the conversion of this standard to other formats or for incorrect results or damages resulting from its use.

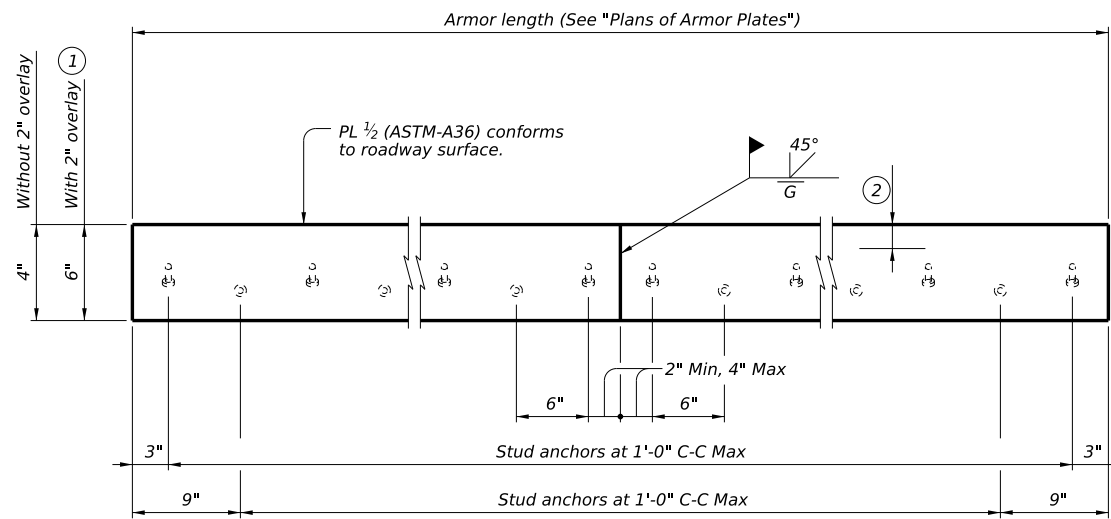

- ① Adjust 6" plate height for overlay thicknesses other than the 2" shown. Adjust weight by 1.70 plf for each 1/2" variation in thickness.
- ② Do not paint top 1 1/2" of plate if using sealed armor joint.
- ③ Set top of backer rod 1" below top of armor plate. Backer rod must be compatible with joint sealant. Use of multiple pieces to create a backer rod cross section is not permitted. Top of backer rod must be convex as shown.
- ④ Blast clean entire contact area between sealant and plate (SSPC-SP10) before installing sealant. Light brush blast and thoroughly clean all dust and debris from concrete surfaces in contact with joint sealant before application of silicone seal.
- ⑤ Use Class 7 joint sealant that conforms to DMS-6310.
- ⑥ Place sealant while ambient temperature is between 55°F and 80°F and is rising.
- ⑦ Armor joint does not include joint sealant or backer rod.
- ⑧ Armor joint (sealed) includes Class 7 joint sealant and backer rod.
- ⑨ Form vertical leg of seal as per the Manufacturer's recommendations. Use Class 4 joint sealant if Class 7 cannot be installed correctly. Install according to Manufacturer's recommendations.
- ⑩ Unless shown otherwise, terminate armor plate at slab break point if break is more than 2'-0" from slab edge.
- ⑪ See "Plans of Armor Plates."
- ⑫ At Fabricator's option, armor plate may extend up to 6" beyond this point for skews through 15°.
- ⑬ Align shipping angle perpendicular to joint.

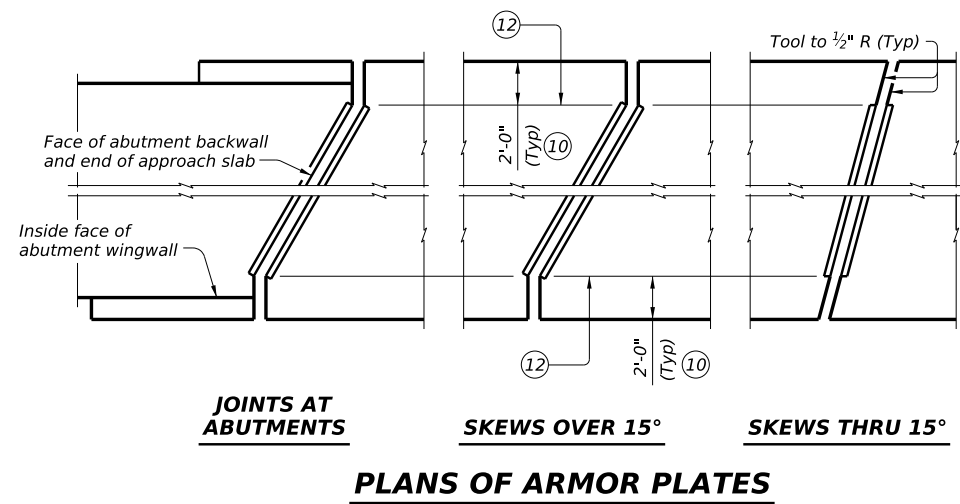
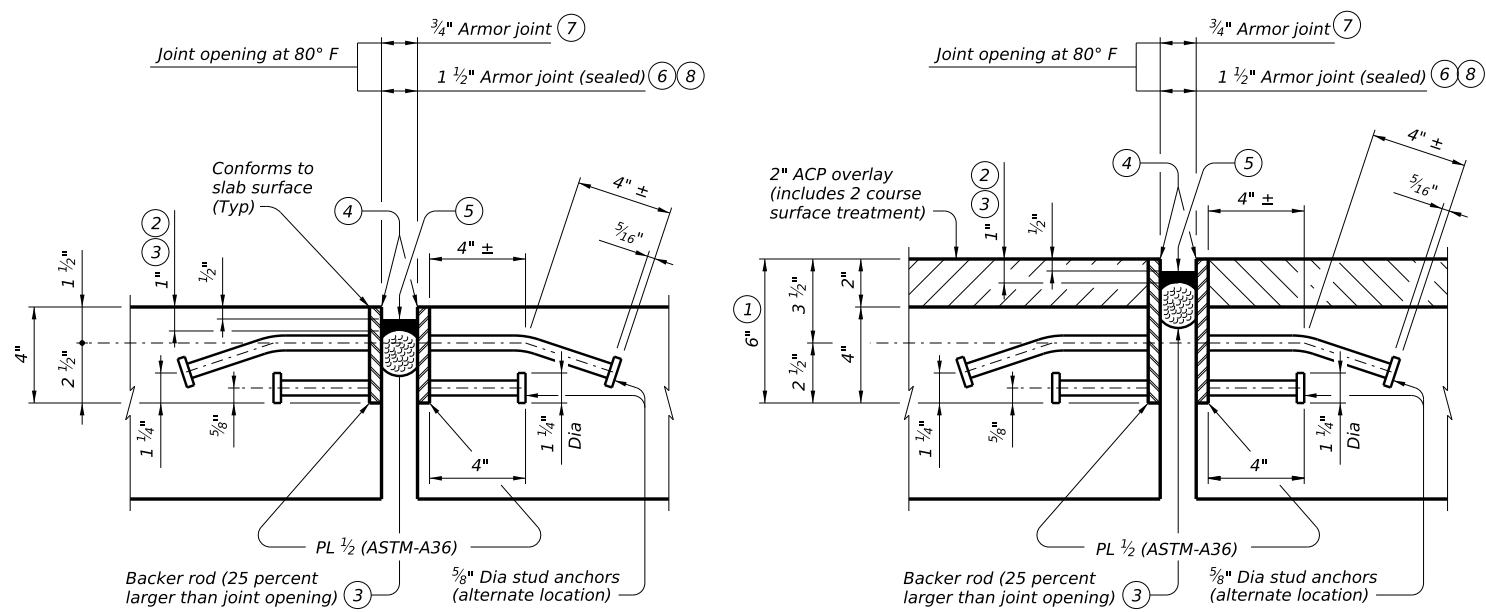

FABRICATION NOTES:

Match mark corresponding plate sections and secure together for shipment with shipping angle. Do not use erection bolts. Ship armor joints in convenient lengths of 10'-0" Min and 24'-0" Max unless necessary for stage construction or widenings. One shop splice is permitted in each shipping length provided no piece is less than 2'-0" long and sufficient studs are added to limit the stud to shop splice distance to 2" Min and 4" Max. Weld studs in accordance with AWS D1.1. Use groove welds for all shop and field butt splices. Grind smooth areas in contact with seal. Make all necessary field splice joint preparations in the shop. Paint the entire steel section, except as stated in Note 2, with System II or IV primer in accordance with Item 446, "Field Cleaning and Painting Steel." Provide paints in accordance with Item 446.2. Prepare steel and apply paint in accordance with Items 446.4.6.3 and 446.4.6.4.4. Shop drawings for the fabrication of armor joints will not require the Engineer's approval if fabrication is in accordance with the details shown on this standard.

CONSTRUCTION NOTES:

Secure armor joints in position and place to proper grade and alignment by welding braces to adjacent reinforcing steel, to prestressed beam stirrups, or to anchors cast in concrete diaphragms. Include cost of temporary bracing in the price bid for Armor Joint. Remove shipping angle immediately after each joint half is secured in place. Grind smooth, and touch up with organic zinc-rich paint.

GENERAL NOTES:

Provide armor joints at locations shown on the plans. Provide the seal when "Armor Joint (Sealed)" is noted on the plans. These joint details accommodate a joint movement range of 1 3/8" (3/4" opening movement and 5/8" closure movement). Payment for armor joint, with or without seal, is based on length of armor plate.

SHOWN WITHOUT 2" OVERLAY AT JOINT LOCATION
SHOWN WITH 2" OVERLAY AT JOINT LOCATION

ARMOR JOINT SECTIONS

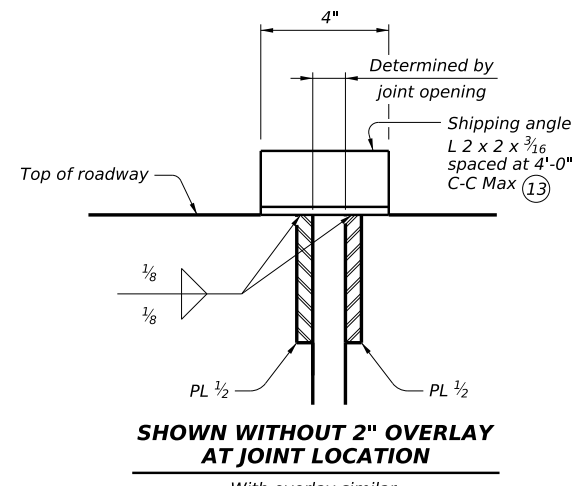
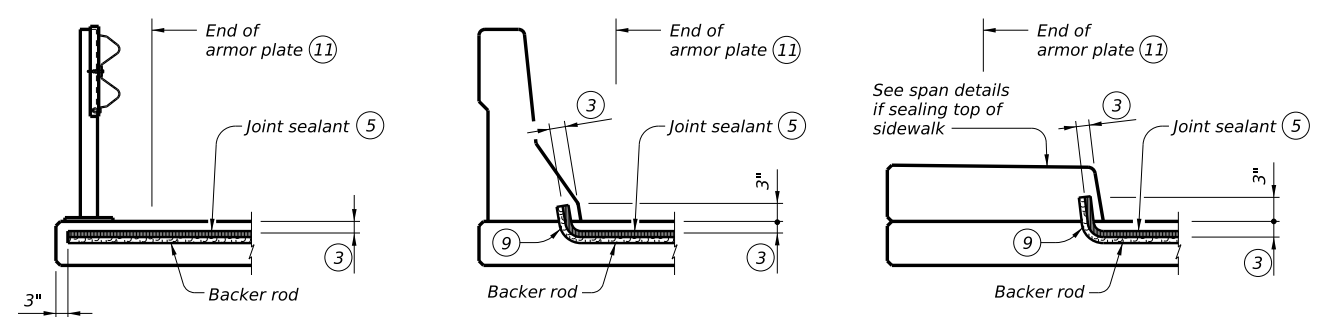

WEIGHTS FOR ONE ARMOR JOINT (2 PLATES)	
WITHOUT OVERLAY	16.10 plf
WITH 2" OVERLAY ①	22.90 plf



ARMOR JOINT DETAILS

AJ

FILE: MS-AJ-24.dgn	DN: TxDOT	CK: TxDOT	DW: TxDOT	CK: TxDOT
©TxDOT October 2024	CONT	SECT	JOB	HIGHWAY
REVISIONS				
	DIST	COUNTY		SHEET NO.

DATE: FILE: