

DISCLAIMER: The use of this standard is governed by the "Texas Engineering Practice Act". No warranty of any kind is made by TxDOT for any purpose whatsoever. TxDOT assumes no responsibility for the conversion of this standard to other formats or for incorrect results or damages resulting from its use.

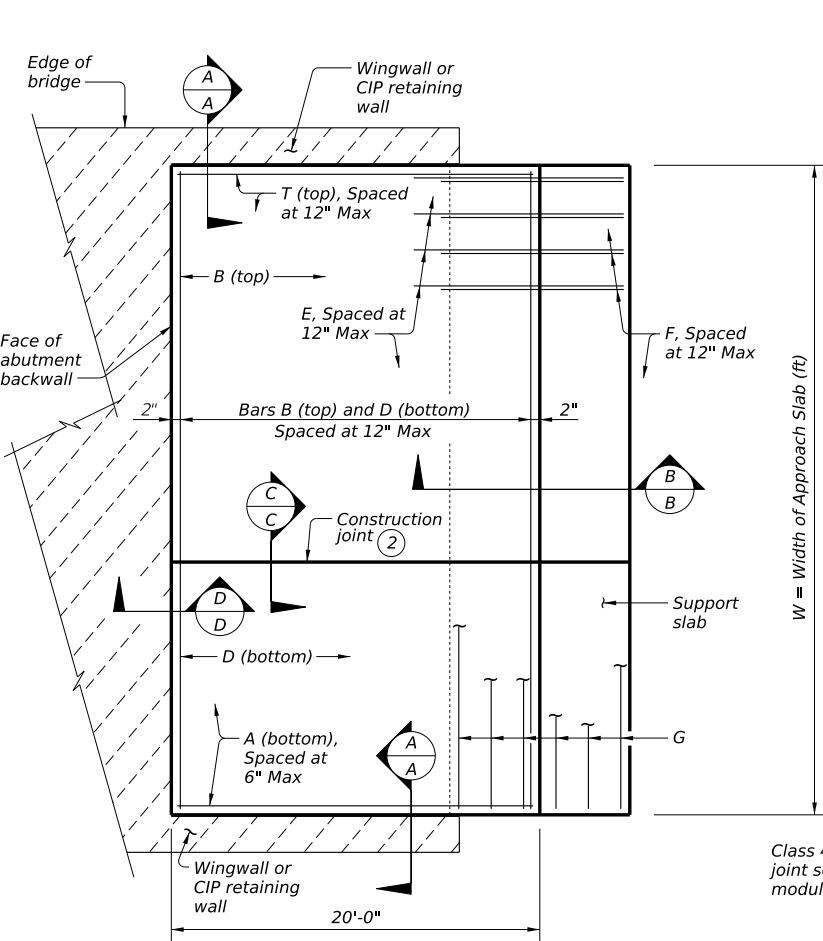

PLAN
(Showing non-skewed approach slab.)

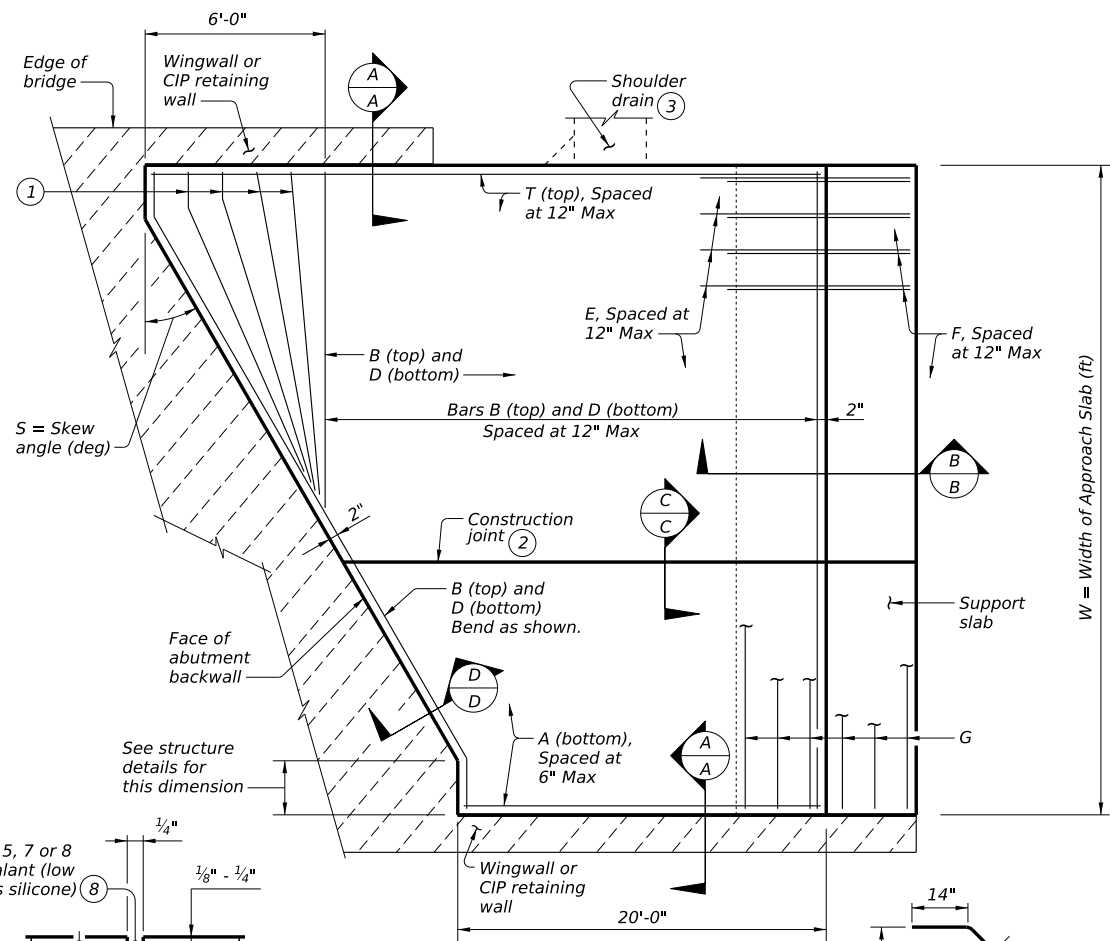

PLAN
(Showing skewed approach slab.)

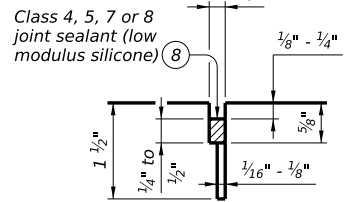

LONGITUDINAL SAW CUT JOINT DETAIL

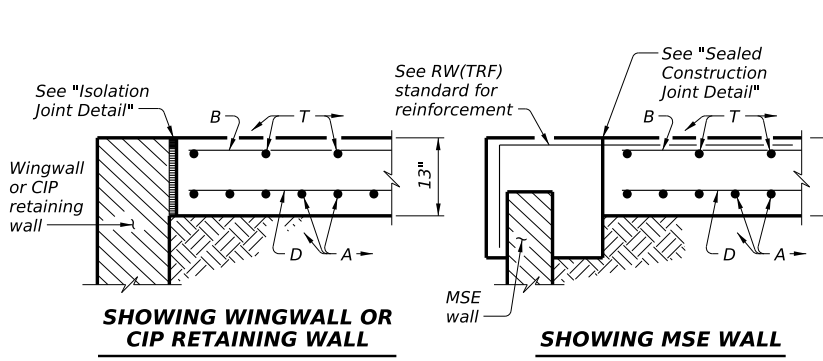
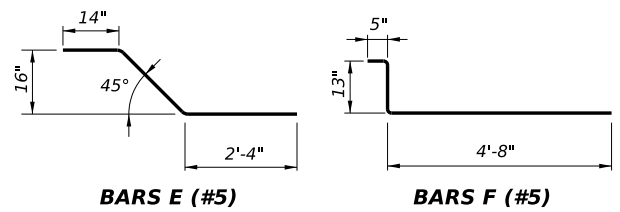

SECTION A-A and **SECTION B-B**

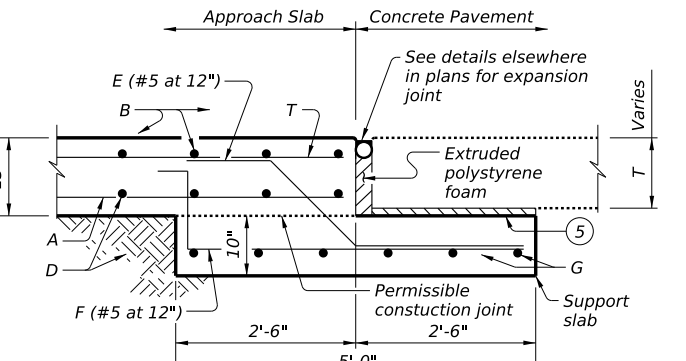

SECTION C-C

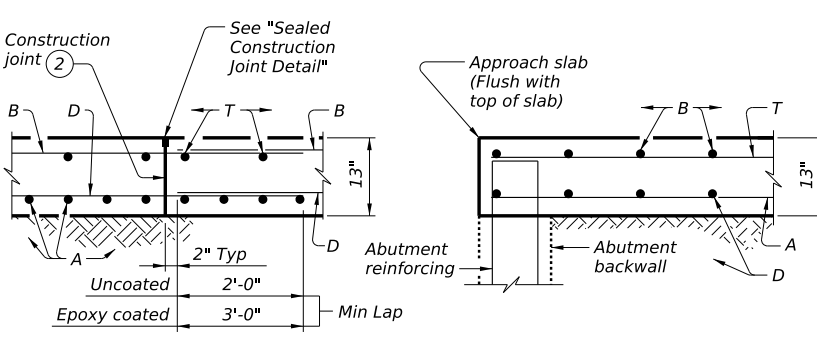

SECTION D-D

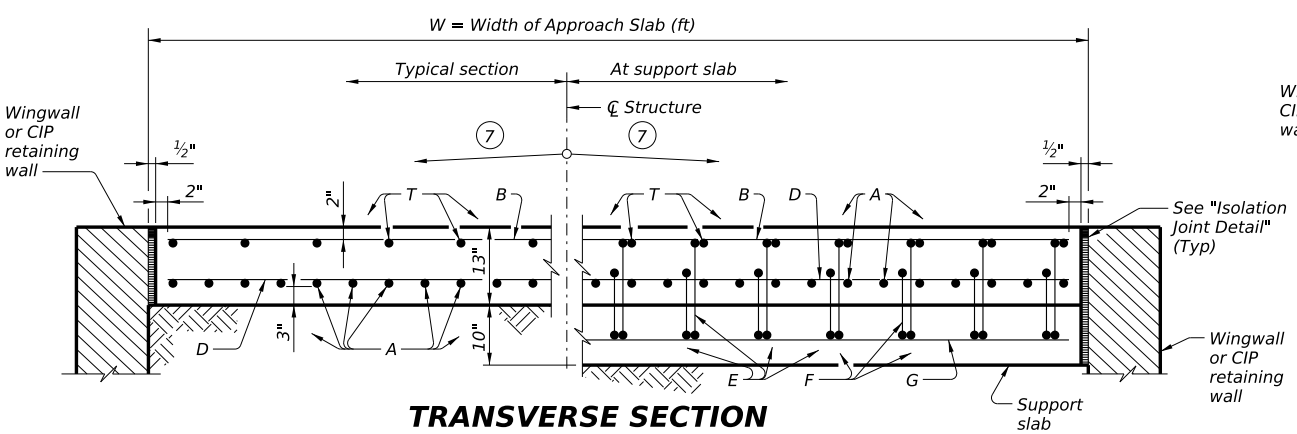

TRANSVERSE SECTION

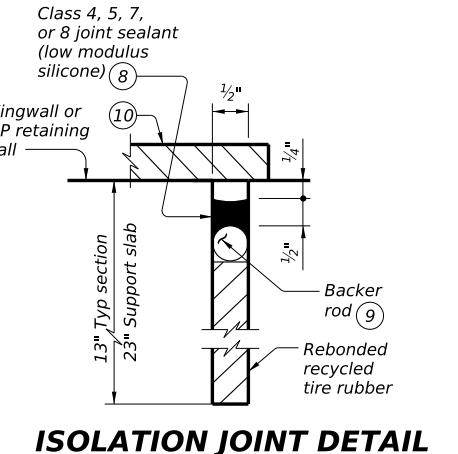

ISOLATION JOINT DETAIL

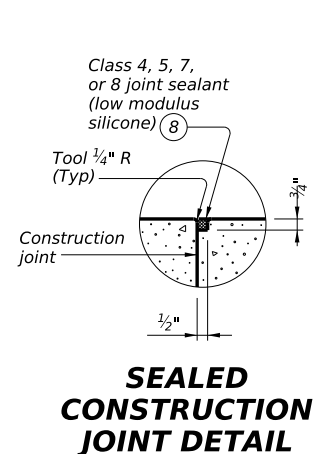

SEALED CONSTRUCTION JOINT DETAIL

BAR TABLE	
BAR	SIZE
A	#8
B	#5
D	#5
E	#5
F	#5
T	#5

APPROXIMATE QUANTITIES (4)	
Reinf steel weight = 8.5 Lbs/SF of Approach Slab = 18.4 Lbs/LF of Support Slab	
Vol of Appr Slab Conc (CY) = 1.057W - 0.008W x T + 0.02W ² Tan S (Includes Support Slab)	
W = Width of Approach Slab (ft)	
T = Conc Pavement Thickness (in)	
S = Skew Angle (deg)	

- Flare Bars B and D in this region (1'-6" Max spacing, 3" Min spacing). Minimum flared bar length = 2'-6". Bend bars as necessary.
- Provide longitudinal construction joints that align with longitudinal construction joints in the bridge slab with bridges built in stages. Other longitudinal construction joints must receive approval of the Engineer.
- See details elsewhere in plans for shoulder drain location and details.
- For Contractor's information only. Quantities shown are for one approach slab only.
- On portion of support slab that supports the concrete pavement, adjust top surface elevation, if required, to accommodate concrete pavement thickness. Smooth trowel finish. Place two layers of 30# roofing felt.
- Multiple piece tie bars are acceptable at longitudinal construction joints provided minimum laps shown are achieved.
- See details elsewhere in plans for required cross-slope.
- Place in accordance with Item 438.
- Provide backer rod that is 25% larger than joint opening and compatible with the sealant.
- If bridge rail is present at the wingwall or CIP retaining wall, place 1/2" rebonded recycled tire rubber between concrete railing and top of approach slab as shown when concrete railing projects over the approach slab.

GENERAL NOTES:
Construct approach slab in accordance with Item 422.
Provide Class "S" concrete with a minimum compressive strength of 4,000 psi.
Provide Grade 60 reinforcing steel.
Provide longitudinal joints as shown on the "Longitudinal Saw Cut Joint Detail" at lane lines and shoulders when width between longitudinal construction joints or edges of approach slab exceeds 16 feet. Saw cut joints within 24 hours of concrete placement to a depth of 1 1/2" and seal in accordance with Item 438. Alternately, provide a controlled joint consisting of 1 1/2" vinyl or plastic joint former (Stress Cap, Zip Strip, Stress Lock, or equal as approved by the Engineer.)
Provide rebonded recycled tire rubber joint filler that meets the requirements of DMS-6310. "Joint Sealants and Fillers."
Construct the subgrade or subbase away from the bridge for a minimum distance of 100 feet prior to the approach slab, unless otherwise indicated on the plans.
Compact and finish the subgrade or foundation for the approach slab to the typical cross-section and to the lines and grades shown on the plans.
Cure for 4 days using water or membrane curing per Item 422. All details shown herein are subsidiary to bridge approach slab.

Cover dimensions are clear dimensions, unless noted otherwise. Reinforcing bar dimensions shown are out-to-out of bar.

		Bridge Division Standard	
BRIDGE APPROACH SLAB CONCRETE PAVEMENT			
BAS-C			
FILE: MS-BAS-C-24.dgn	DN: TxDOT	CK: TxDOT	DW: TxDOT
©TxDOT October 2024	CONT	SECT	JOB
REVISIONS			HIGHWAY
	DIST	COUNTY	SHEET NO.

DATE: FILE: