

DISCLAIMER: The use of this standard is governed by the "Texas Engineering Practice Act". No warranty of any kind is made by TxDOT for any purpose whatsoever. TxDOT assumes no responsibility for the conversion of this standard to other formats or for incorrect results or damages resulting from its use.

- 1 Applicable to EE bearings only.
- 2 Min DL can be reduced by the ratio of (actual exp length/max exp length).
- 3 Locate "Bearing Type" identification here.
- 4 Locate permanent mark here.
- 5 Min Bearing Seat width, normal to girder, is "S" + 8".
- 6 See span details for beam grade (slope) at bearing locations.

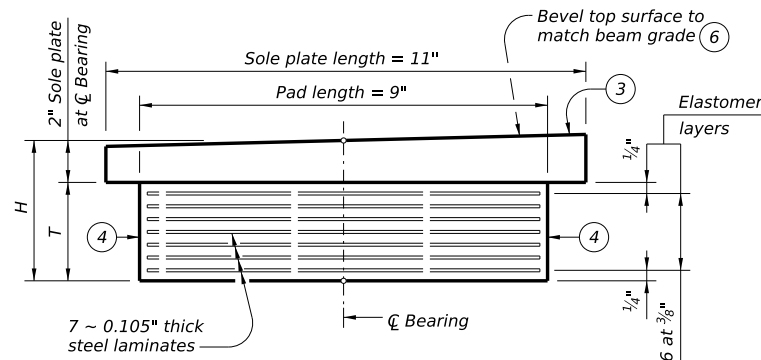

**TYPE EE & EF LAMINATED ELASTOMERIC BEARING DETAIL**

(50 Durometer) (Vulcanize sole plate to elastomer)

Bearing Type	Neoprene Pad		Sole Plate		H	S	T	Flange Width		Reactions (Unfactored)			Max Expansion Length 1
	Width	Length	Width	Length				Min	Max	1 Min DL	2 Max DL	Max Total	
	in	in	in	in				in	in	kip	kip	kip	
EE1 or EF1	15	9	25.5	11	5.5	20.0	3.49	10	15	59	115	144	250
EE2 or EF2	18	9	28.5	11	5.5	23.0	3.49	10	18	71	148	185	250
EE3 or EF3	21	9	31.5	11	5.5	26.0	3.49	11	21	83	181	226	250
EE4 or EF4	24	9	34.5	11	5.5	29.0	3.49	14	24	95	215	269	250
EE5 or EF5	27	9	37.5	11	5.5	32.0	3.49	17	27	106	249	312	250
EE6 or EF6	30	9	40.5	11	5.5	35.0	3.49	20	30	118	284	355	250
EE7 or EF7	32	9	42.5	11	5.5	37.0	3.49	22	32	126	307	384	250
EE8 or EF8	34	9	44.5	11	5.5	39.0	3.49	24	34	134	331	414	250
EE9 or EF9	36	9	46.5	11	5.5	41.0	3.49	26	36	142	355	443	250

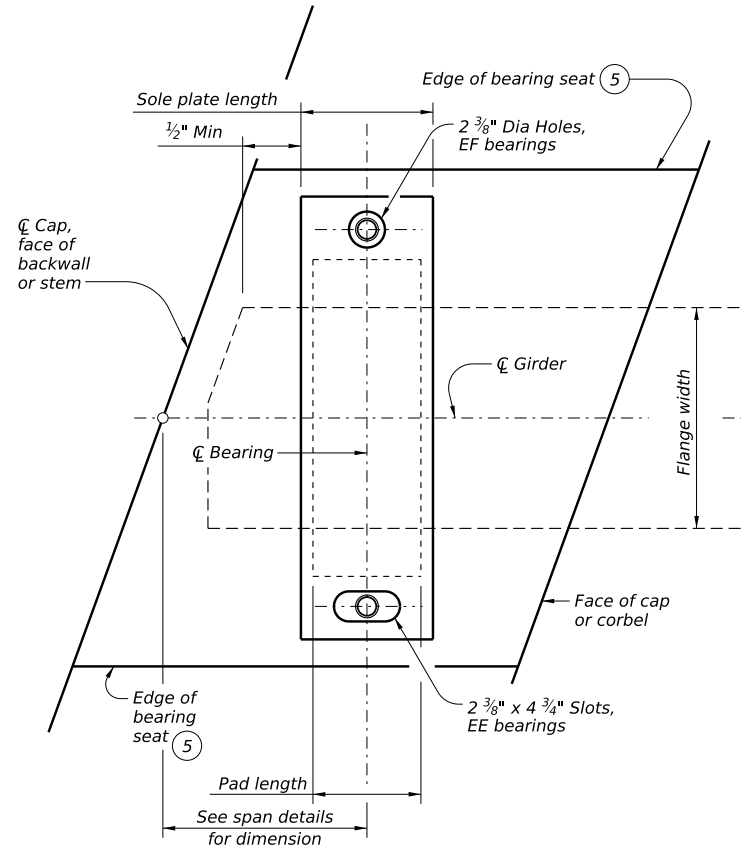

**PLAN**

Pipe sleeves, washers and nuts not shown for clarity

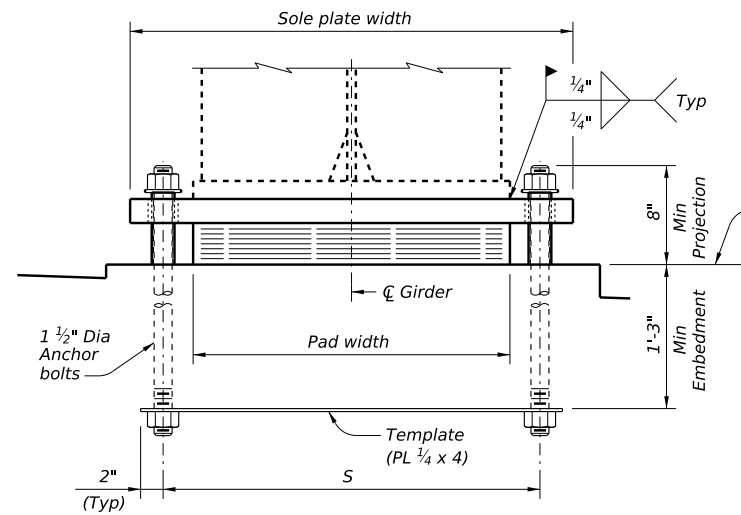

**FRONT ELEVATION**

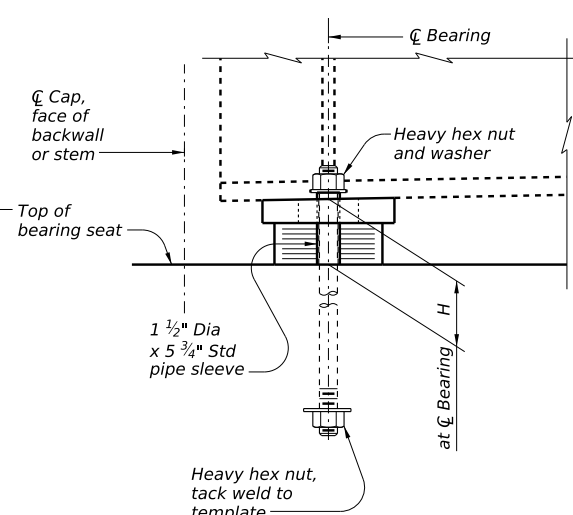

**SIDE ELEVATION**

**END FIXED (EF) AND EXPANSION (EE) BEARINGS**

Paid for at unit price bid for "Elastomeric Bearing" as per Item 434.

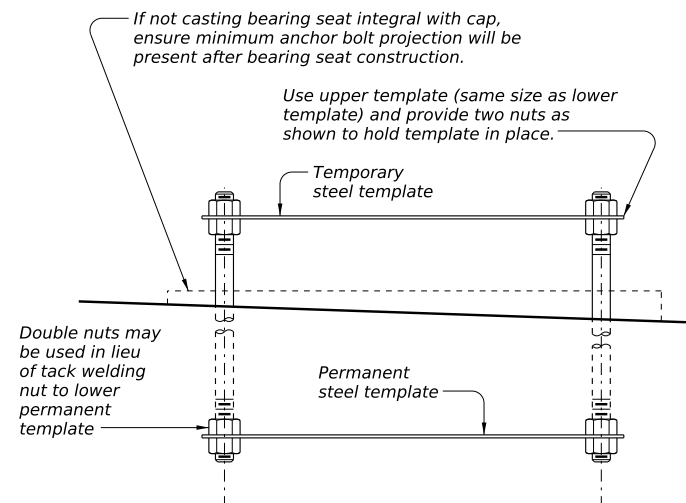

**ANCHOR BOLT SETTING DETAIL**

Applies to all bearings on this standard. Verify and correct, if necessary, anchor bolt location immediately after concrete placement, before initial set.

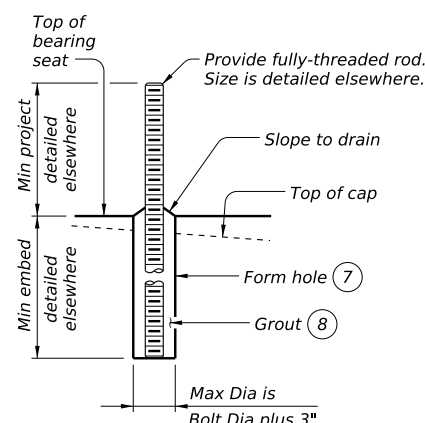

**OPTIONAL ANCHOR BOLT SETTING DETAIL**

Applies to all bearings on this standard.

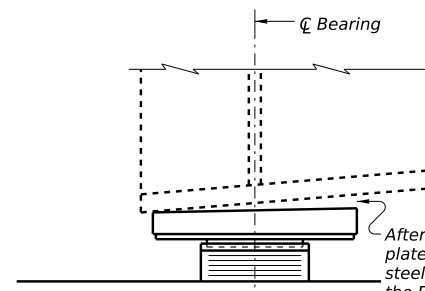

**GIRDER TO SOLE PLATE WELD DETAIL**

Applies to all end bearings on this standard. Small gaps between girders and sole plates are anticipated under steel dead load only.

**MATERIAL NOTES:**

Provide anchor bolts conforming to ASTM F1554 Grade 105 or ASTM A193 Grade B7. Provide nuts conforming to ASTM A563 Grade DH, heavy hex or A194 Grade 2H, heavy hex. Provide washers conforming to ASTM F436. Provide pipe sleeves conforming to the requirements of ASTM A53 Grade B or A 500 Grade B. Hot-dip galvanize all anchor bolts (exposed end plus 6" Min), nuts not embedded in concrete, and pipe sleeves as per Item 445, "Galvanizing." For painted bridges, provide steel for sole plates conforming to ASTM A36 or A588. For unpainted (weathering) bridges, provide steel for sole plates conforming to ASTM A588.

**GENERAL NOTES:**

The bearings shown on this standard are intended for use with continuous and simple span rolled beams and plate girders. None of the bearings shown are designed to resist uplift. See span details for bearing type and location. The bearing fabricator is required to develop a bearing layout which identifies location and orientation of all bearings. Permanently mark each bearing in accordance with the bearing layout. A copy of the bearing layout is to be provided to the Engineer. Submit shop drawings for approval. Dimension sole plates to the nearest 1/16" based on required thickness at centerline of bearing and slope of the girder in the finished structure. Thickness tolerance variation from the shop drawings is 1/16" +/-, except the variation from a plane parallel to the theoretical top surface can not exceed 1/16" total. Install anchor bolt nuts finger-tight or loosely snug.

All bearings on this standard require wood float bearing seat surfaces that are clean and free of all loose material before placement of bearings.

These bearings are not intended for use with bridges over 100 ft wide. The anchor bolts are not designed to restrain temperature-induced lateral movement.

- 7 Form hole with either plastic duct meeting the requirements of Item 426.2.2 or galvanized corrugated metal post-tensioning duct. Do not use PVC or other smooth plastic or steel duct. Do not drill hole.
- 8 Fill void with a pre-qualified grout conforming to DMS-4675 and capable of 4,000 psi compressive strength. Void may also be filled with epoxy grout using Type VIII epoxy conforming to DMS-6100. Clean holes before filling.

SHEET 1 OF 3



**ELASTOMERIC BEARING DETAILS STEEL GIRDERS AND BEAMS**

**SGEB**

FILE: MS-SGEB-24.dgn	DN: TxDOT	CK: TxDOT	DW: TxDOT	CK: TxDOT
©TxDOT October 2024	CONT	SECT	JOB	HIGHWAY
REVISIONS				
DIST	COUNTY			SHEET NO.

DATE: FILE:

DISCLAIMER: The use of this standard is governed by the "Texas Engineering Practice Act". No warranty of any kind is made by TxDOT for any purpose whatsoever. TxDOT assumes no responsibility for the conversion of this standard to other formats or for incorrect results or damages resulting from its use.

DATE: FILE:

### TABLE OF INTERIOR BEARING DESIGNS

Bearing Type	Neoprene Pad		Sole Plate		H	S	T	Flange Width		Reactions (Unfactored)			Max Expansion Length (9)
	Width	Length	Width	Length				Min	Max	(9) (2) Min DL	Max DL	Max Total	
	in	in	in	in				in	in	in	kip	kip	kip
E1 or F1	15	10	27.0	12	5.1	20.5	3.09	10	15	66	180	225	206
E2 or F2	18	10	30.0	12	5.1	23.5	3.09	10	18	79	216	270	206
E3 or F3	21	10	33.0	12	5.1	26.5	3.09	11	21	92	252	315	206
E4 or F4	24	14	38.5	16	6.4	30.5	4.45	12	24	147	403	504	321
E5 or F5	27	14	41.5	16	6.4	33.5	4.45	15	27	165	454	567	321
E6 or F6	30	14	44.5	16	6.4	36.5	4.45	18	30	184	504	630	321
E7 or F7	32	16	48.0	18	6.9	39.0	4.93	19	32	224	614	768	355
E8 or F8	34	16	50.0	18	6.9	41.0	4.93	21	34	238	653	816	355
E9 or F9	36	16	52.0	18	6.9	43.0	4.93	23	36	252	691	864	355

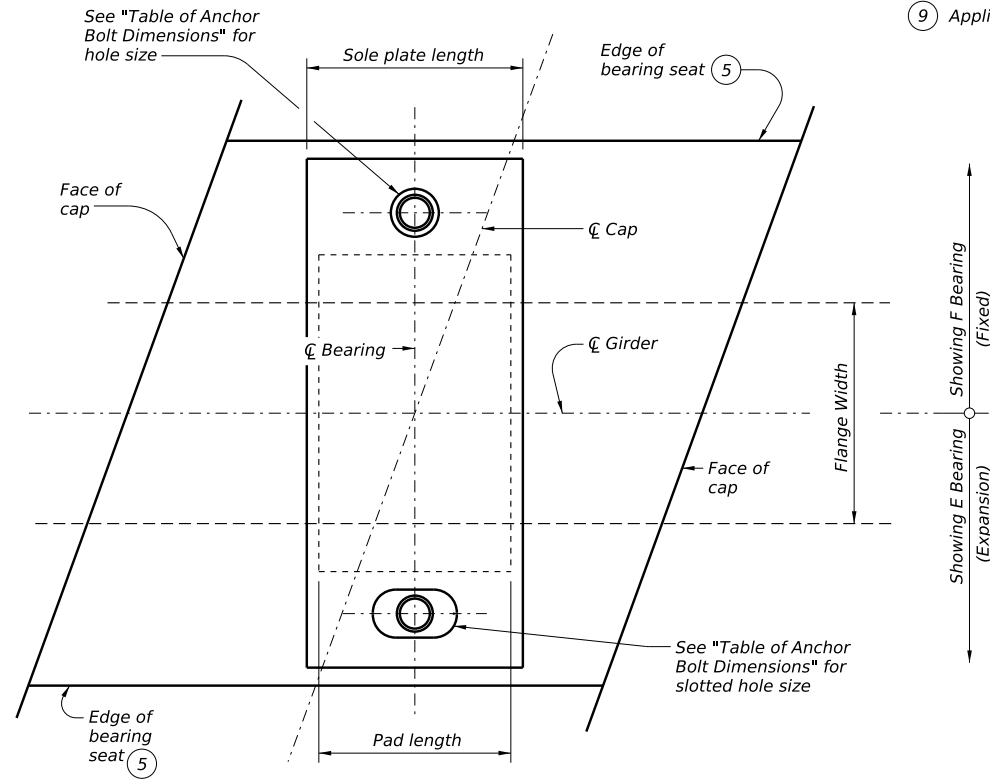

#### PLAN

Pipe sleeves, washers and nuts not shown for clarity

- 2 Min DL can be reduced by the ratio of (actual exp length/max exp length).
- 3 Locate "Bearing Type" identification here.
- 4 Locate permanent mark here.
- 5 Min Bearing Seat width, normal to girder, is "S" + 8".
- 6 See span details for beam grade (slope) at bearing locations.
- 9 Applicable to E bearings only.

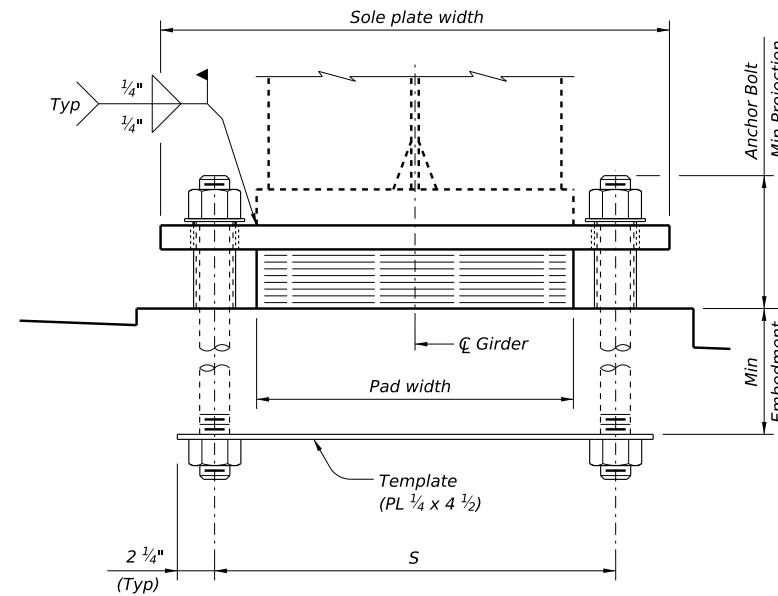

#### FRONT ELEVATION

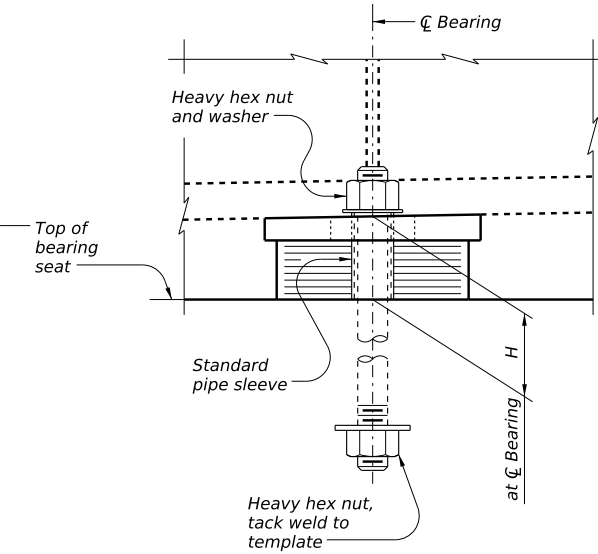

#### SIDE ELEVATION

### INTERIOR FIXED (F) AND EXPANSION (E) BEARINGS

Paid for at unit price bid for "Elastomeric Bearing" as per Item 434.

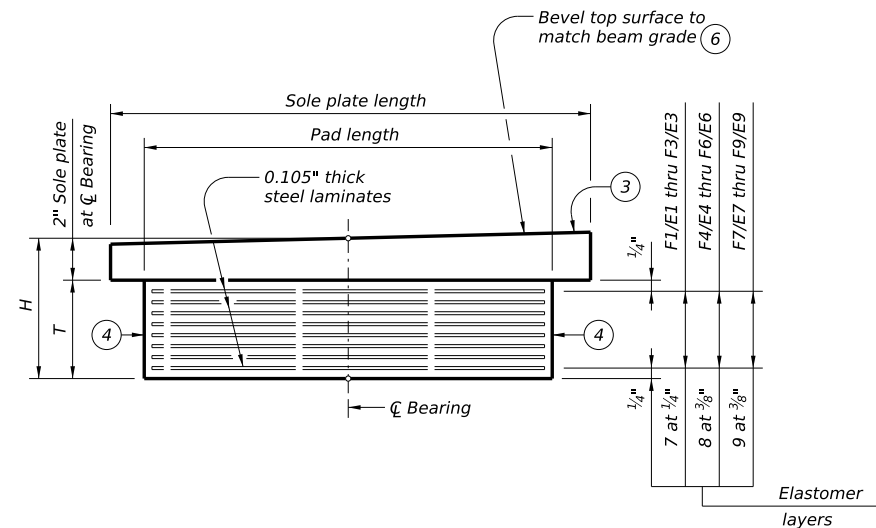

#### TYPE E & F LAMINATED ELASTOMERIC BEARING DETAIL

(50 Durometer) (Vulcanize sole plate to elastomer)

### TABLE OF ANCHOR BOLT DIMENSIONS FOR TYPE E AND F BEARINGS

Bearing Type	Anchor Bolt Dia	Pipe Sleeve Size (Dia x Length)	Sole Plate Hole Size	Anchor Bolt	
				Embedment	Projection
F1 thru F3	1 3/4"	2" x 5 3/8"	2 3/4" Dia	1'- 6"	8"
F4 thru F6	2 1/4"	2 1/2" x 6 5/8"	3 1/4" Dia	2'- 0"	9 1/2"
F7 thru F9	2 1/2"	3" x 7 1/4"	3 7/8" Dia	2'- 1"	10 1/2"
E1 thru E3	1 3/4"	2" x 5 3/8"	2 3/4" x 4 1/2"	1'- 6"	8"
E4 thru E6	2 1/4"	2 1/2" x 6 5/8"	3 1/4" x 6 1/4"	2'- 0"	9 1/2"
E7 thru E9	2 1/2"	3" x 7 1/4"	3 7/8" x 7"	2'- 1"	10 1/2"

SHEET 2 OF 3



## ELASTOMERIC BEARING DETAILS STEEL GIRDERS AND BEAMS

### SGEB

FILE: MS-SGEB-24.dgn	DN: TxDOT	CK: TxDOT	DW: TxDOT	CK: TxDOT
©TxDOT October 2024	CONT	SECT	JOB	HIGHWAY
REVISIONS	DIST		COUNTY	SHEET NO.

DISCLAIMER: The use of this standard is governed by the "Texas Engineering Practice Act". No warranty of any kind is made by TxDOT for any purpose whatsoever. TxDOT assumes no responsibility for the conversion of this standard to other formats or for incorrect results or damages resulting from its use.

DATE: FILE:

**TABLE OF END SLIDING BEARING DESIGNS**

Bearing Type	Neoprene Pad		Sole Plate		H	S	T	Flange Width		Reactions (Unfactored)		Max Expansion Length
	Width	Length	Width	Length				Min	Max	Max DL	Max Total	
ES1	15	9	25.5	17	5.5	20.0	2.65	10	15	108	203	500
ES2	18	9	28.5	17	5.5	23.0	2.65	10	18	130	243	500
ES3	21	9	31.5	17	5.5	26.0	2.65	11	21	151	284	500
ES4	24	9	34.5	17	5.5	29.0	2.65	14	24	173	324	500
ES5	27	9	37.5	17	5.5	32.0	2.65	17	27	194	365	500
ES6	30	9	40.5	17	5.5	35.0	2.65	20	30	216	405	500
ES7	32	9	42.5	17	5.5	37.0	2.65	22	32	230	432	500
ES8	34	9	44.5	17	5.5	39.0	2.65	24	34	245	459	500
ES9	36	9	46.5	17	5.5	41.0	2.65	26	36	259	486	500

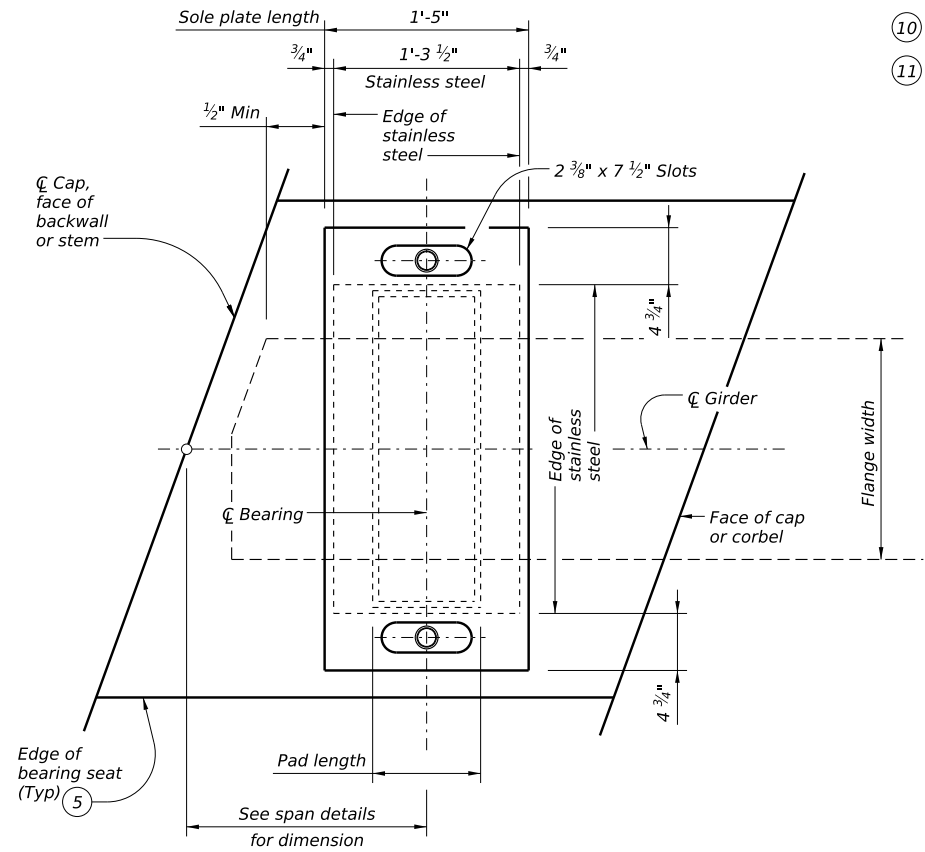

**PLAN**

Pipe sleeves, washers and nuts not shown for clarity

- 3 Locate "Bearing Type" identification here.
- 4 Locate permanent mark here.
- 5 Min bearing seat width, normal to girder, is "S" + 8".
- 6 See span details for beam grade (slope) at bearing locations.
- 10 Bond PTFE to 1/2" plate with an approved adhesive.
- 11 Provide steel for 1/2" plate conforming to ASTM A36. Vulcanize plate to elastomer. Paint plate (in the shop) with System III-B in accordance with Item 446. No paint is permitted in recess or on PTFE.

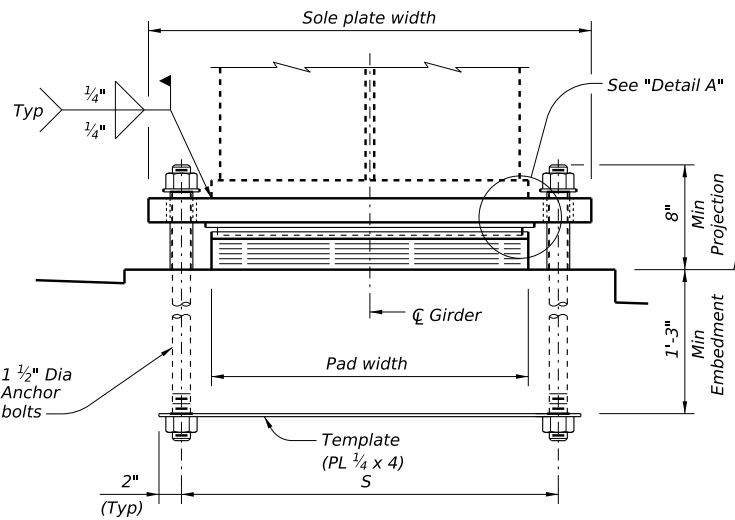

**FRONT ELEVATION**

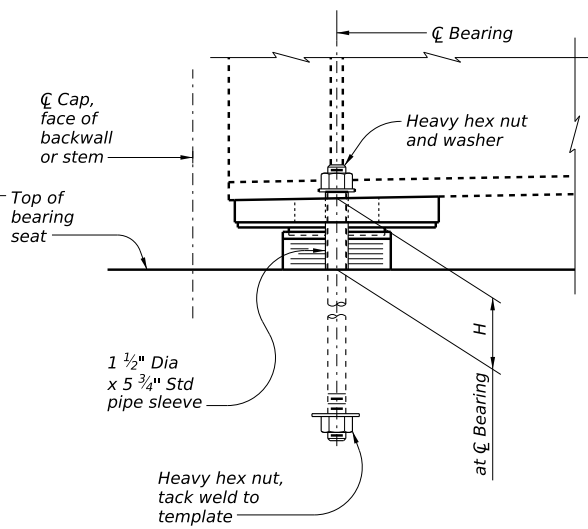

**SIDE ELEVATION**

**END SLIDING (ES) EXPANSION BEARINGS**

Paid for at unit price bid for "Sliding Elastomeric Bearing" as per Item 434.

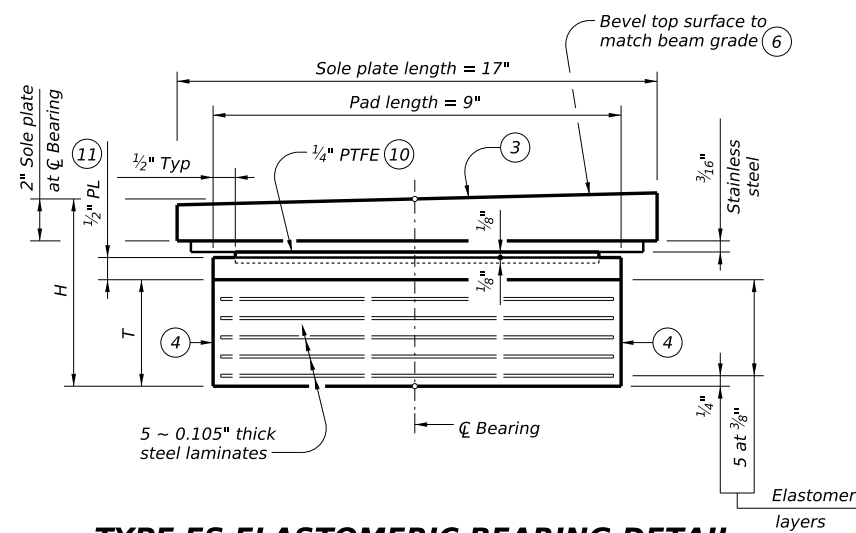

**TYPE ES ELASTOMERIC BEARING DETAIL**

(70 Durometer)

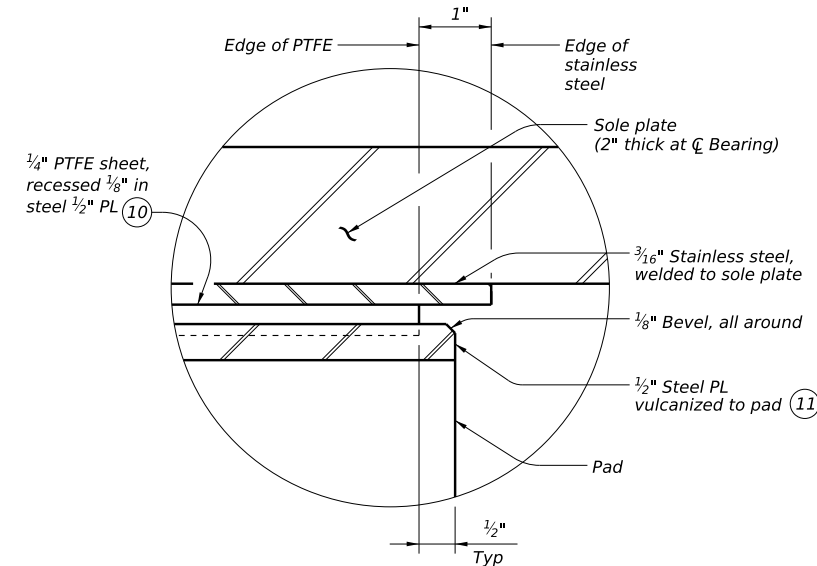

**DETAIL A**

SHEET 3 OF 3



**ELASTOMERIC BEARING DETAILS STEEL GIRDERS AND BEAMS**

**SGEB**

FILE: MS-SGEB-24.dgn	DN: TxDOT	CK: TxDOT	DW: TxDOT	CK: TxDOT
©TxDOT October 2024	CONT	SECT	JOB	HIGHWAY
REVISIONS				
	DIST	COUNTY		SHEET NO.