

DISCLAIMER: This standard is governed by the "Texas Engineering Practice Act". No warranty of any kind is made by TxDOT for any purpose whatsoever. TxDOT assumes no responsibility for the conversion of this standard to other formats or for incorrect results or damages resulting from its use.

DATE: FILE:

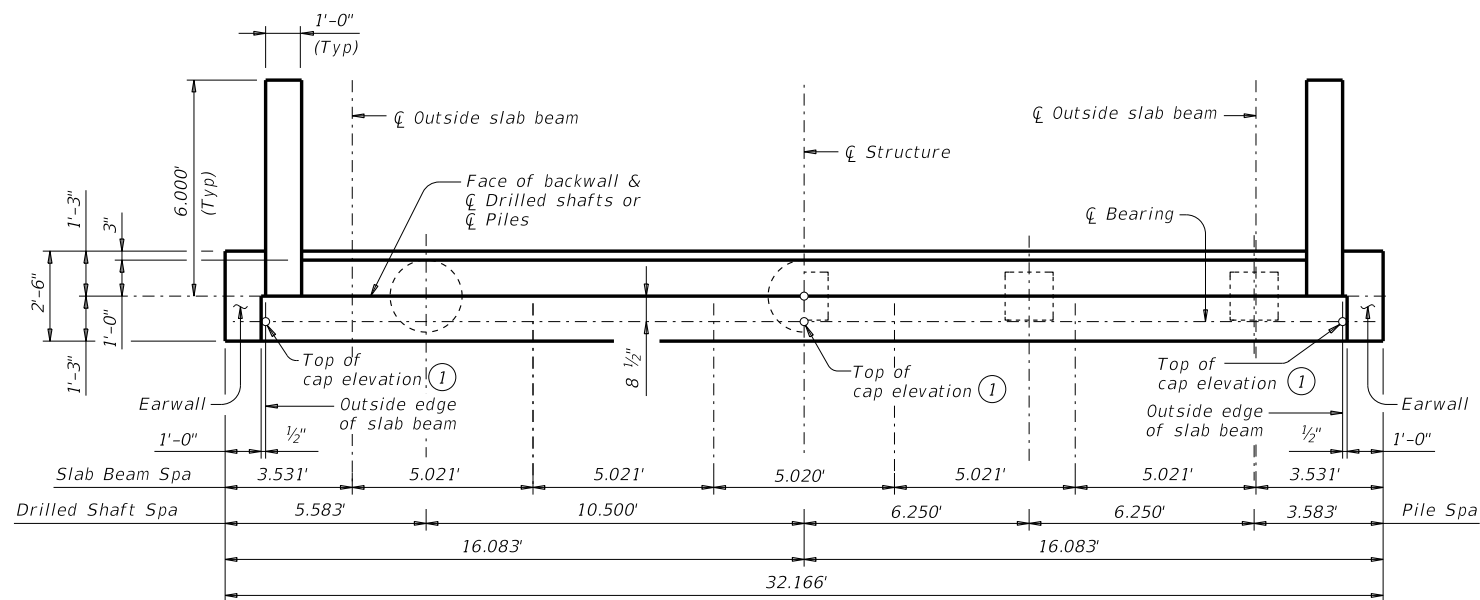

SHOWING DRILLED SHAFTS PLAN SHOWING PILES

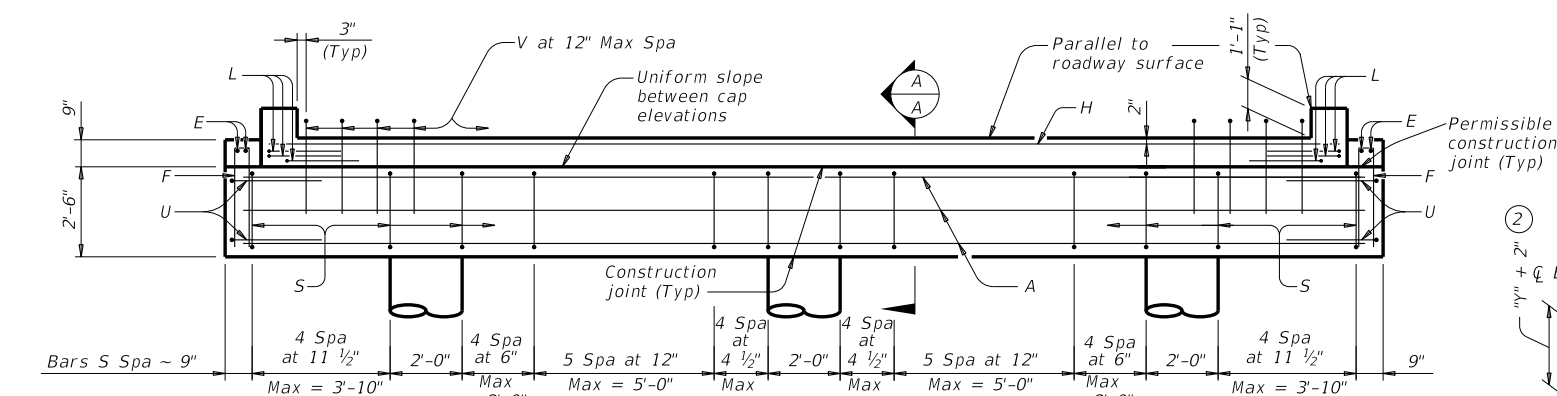

ELEVATION ~ DRILLED SHAFT ABUTMENT

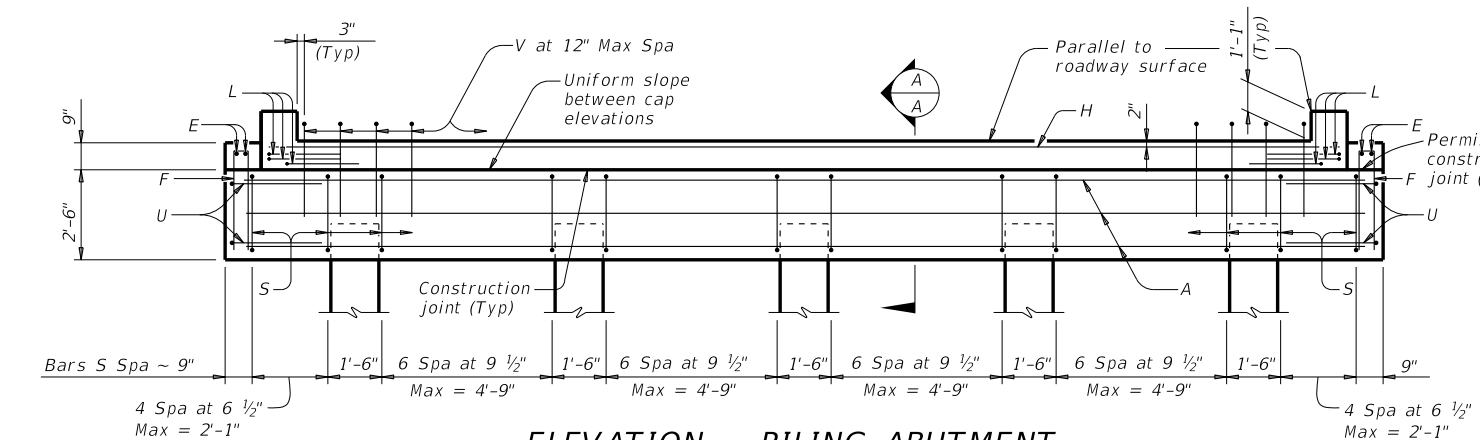

ELEVATION ~ PILING ABUTMENT

Note: For piles larger than 16", adjust Bars S spacing as required to avoid piles.

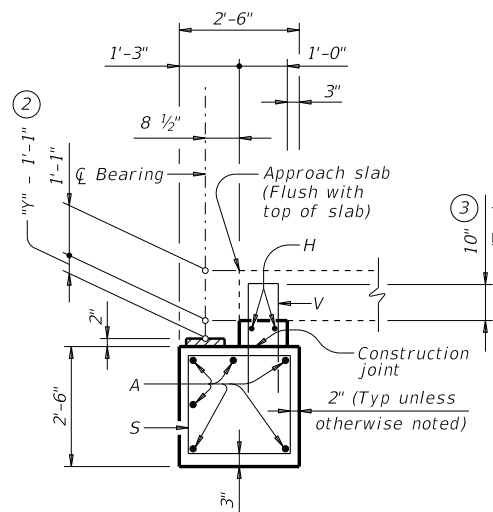
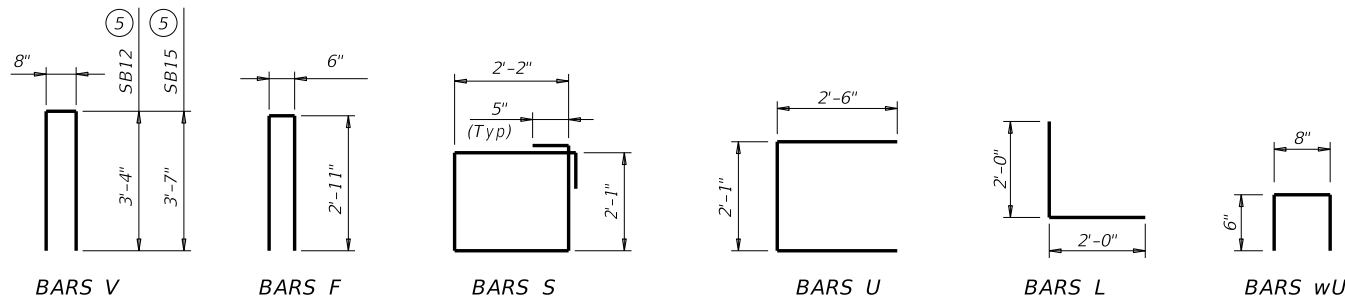

SECTION A-A

(With Approach Slab)  
Note: At Contractor's option, backwall may be cast with approach slab.

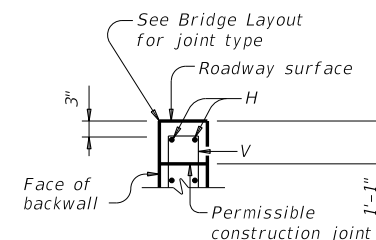

BACKWALL DETAIL

(Without Approach Slab)  
Note: At Contractor's option, backwall may be cast in one lift to roadway surface.

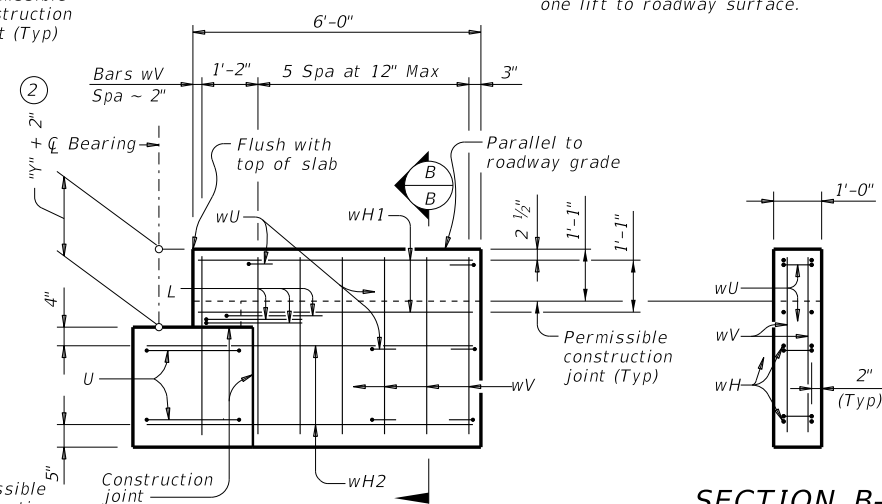

WINGWALL ELEVATION

(Earwall not shown for clarity.)

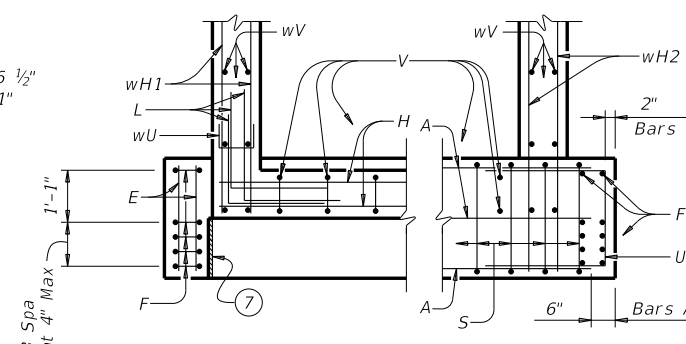

BACKWALL CAP CORNER DETAILS

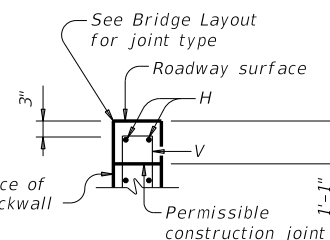

ROADWAY SURFACE

BACKWALL DETAIL

(Without Approach Slab)  
Note: At Contractor's option, backwall may be cast in one lift to roadway surface.

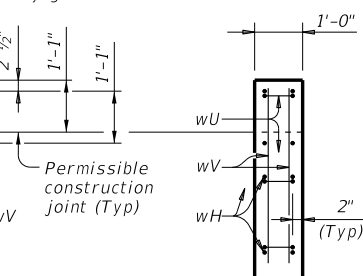

SECTION B-B

FOUNDATION LOADS				
Span Length	Drilled Shaft Loads		Vertical Pile Loads	
	5SB12	5SB15	5SB12	5SB15
Ft	Tons/DS	Tons/DS	Tons/Pile	Tons/Pile
25	42	44	25	27
30	46	50	28	30
35	51	55	31	33
40	55	60	33	36
45	64	69	39	42
50				

TABLE OF ESTIMATED QUANTITIES							
Bar	No.	Size	Length (5)		Weight (5)		
			5SB12	5SB15	5SB12	5SB15	
A	6	#11	31'-2"	31'-2"	994	994	
E	4	#4	2'-2"	2'-2"	6	6	
F	10	#4	6'-4"	6'-4"	43	43	
H	2	#5	29'-9"	29'-9"	62	62	
L	6	#6	4'-0"	4'-0"	36	36	
S	38	#4	9'-4"	9'-4"	237	237	
U	4	#6	7'-1"	7'-1"	43	43	
V	29	#5	7'-4"	7'-10"	222	237	
wH1	8	#6	5'-8"	5'-8"	68	68	
wH2	8	#6	6'-11"	6'-11"	83	83	
wU	12	#4	1'-8"	1'-8"	14	14	
wV	28	#5	3'-10"	4'-1"	112	119	
Reinforcing Steel					Lb	1,920	1,942
CI "C" Conc (Abut)					CY	9.9	10.3

- Top of cap elevations are based on section depths shown on Span Details.
- See Span Details for "Y".
- Increase as required to maintain 3" from finished grade.
- See Bridge Layout to determine if approach slab is present.
- See Bridge Layout for beam type used in the superstructure.
- Quantities shown are for one abutment only (with approach slab). Without approach slab, add 1.1 CY Class "C" concrete and 62 Lb reinforcing steel for 2 additional Bars H.
- 1/2" preformed bituminous fiber material between slab beam and earwall. Bond to earwall with an approved adhesive. Cast inside face of earwall perpendicular to cap. (Typ)

**GENERAL NOTES:**  
Designed according to AASHTO LRFD Bridge Design Specifications.  
Designed for a normal embankment header slope of 3:1 and a maximum span length of 50 feet.  
See Bridge Layout for header slope and foundation type, size, and length.  
See Common Foundation Details (FD) standard sheet for all foundation details and notes.  
See Concrete Riprap (CRR) standard sheet or Stone Riprap (SRR) standard sheet for riprap attachment details, if applicable.  
See applicable rail details for rail anchorage in wingwalls.  
These abutment details may be used with standard SPSB-28 only.

Cover dimensions are clear dimensions, unless noted otherwise.  
Reinforcing bar dimensions shown are out-to-out of bar.

**MATERIAL NOTES:**  
Provide Class C concrete (f<sub>c</sub> = 3,600 psi).  
Provide Class C (HPC) concrete if shown elsewhere in the plans.  
Provide Grade 60 reinforcing steel.

HL93 LOADING

Texas Department of Transportation  
Bridge Division Standard

**ABUTMENTS  
PRESTR CONC SLAB BEAM  
28' ROADWAY**

APSB-28

FILE: PSB-APSB2800-17.dgn	DN: TxDOT	CK: TxDOT	DW: TxDOT	CK: TxDOT
©TxDOT January 2017	CONT	SECT	JOB	HIGHWAY
REVISIONS	DIST	COUNTY	SHEET NO.	