

DISCLAIMER: This standard is governed by the "Texas Engineering Practice Act." No warranty of any kind is made by TxDOT for any purpose whatsoever. TxDOT assumes no responsibility for the conversion of this standard to other formats or for incorrect results or damages resulting from its use.

DATE: FILE:

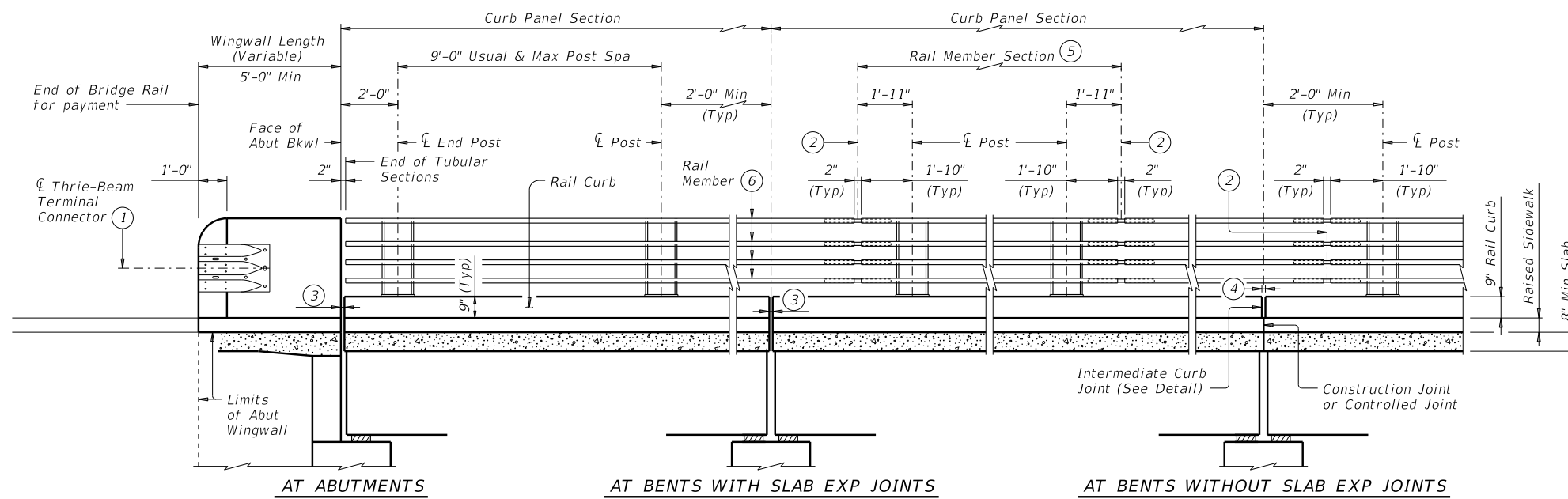

INTERMEDIATE CURB JOINT DETAIL

Provide at all interior bents without slab expansion joints.

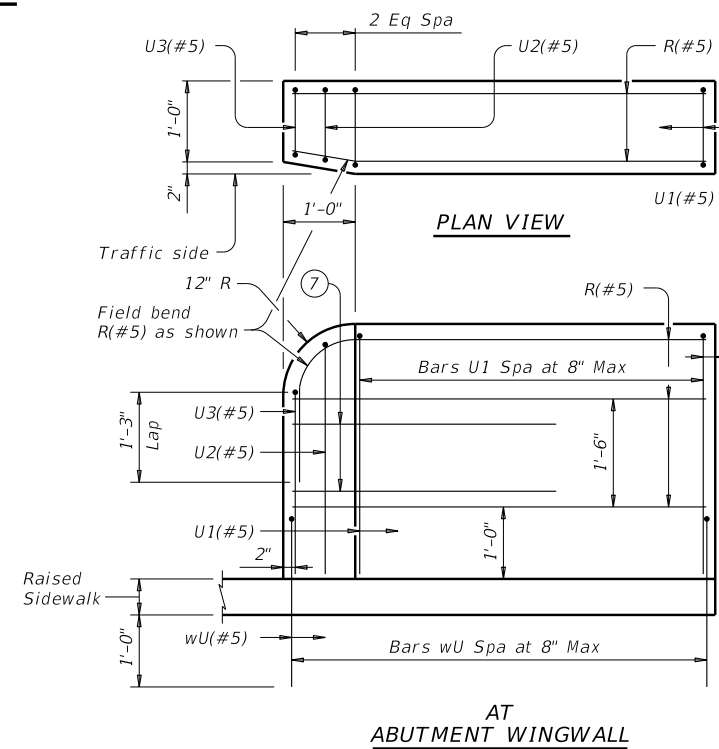
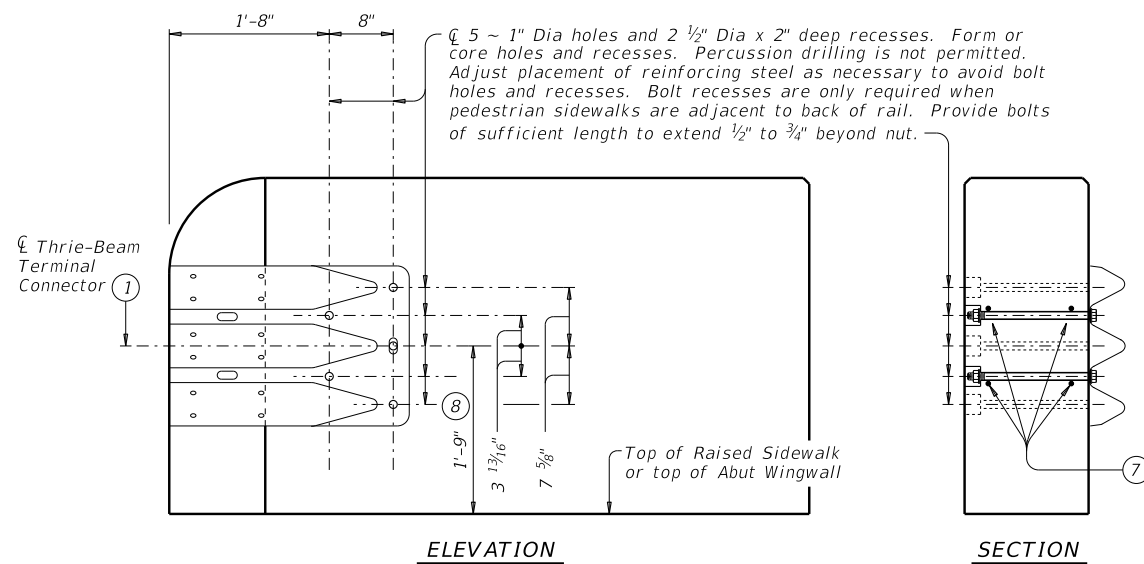
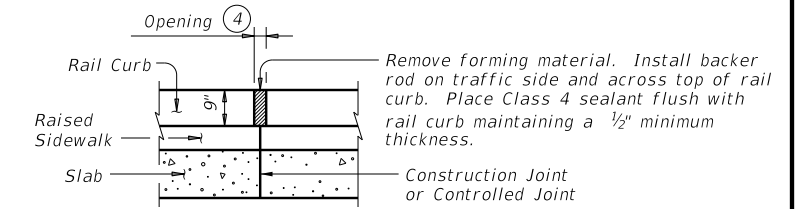

- ① Terminal Connectors and associated hardware are to be paid for under the Item "Metal Beam Guard Fence." Attach Metal Beam Guard Fence Transitions to the bridge rail and extend along the embankment unless otherwise shown in the plans.
- ② Expansion Joint or Splice Joint as required.
- ③ Same as slab joint opening. (5" Max Expansion Joint).
- ④ 1/4" Min, 3/4" Max.
- ⑤ Rail member sections must have at least two posts but not more than four.
- ⑥ HSS 6 x 2 x 1/4 (ASTM-A1085 or A500 Grade B).

- ⑦ Place 4 additional Bars R(#5) 3'-8" in length inside Bars U(#5) and centered 2'-0" from end of rail when Terminal Connections are required. Field bend as needed.
- ⑧ Increase 2" for structures with Overlay.

SHEET 1 OF 4

		Bridge Division Standard	
<h2>COMBINATION RAIL</h2>			
<h3>TYPE CIW</h3>			
FILE: RL-CIW-19.dgn	DN: TxDOT	CK: TxDOT	DW: JTR
©TxDOT September 2019	CONT	SECT	JOB
REVISIONS		HIGHWAY	
DIST	COUNTY	SHEET NO.	

DISCLAIMER: The use of this standard is governed by the "Texas Engineering Practice Act." No warranty of any kind is made by TxDOT for any purpose whatsoever. TxDOT assumes no responsibility for the conversion of this standard to other formats or for incorrect results or damages resulting from its use.

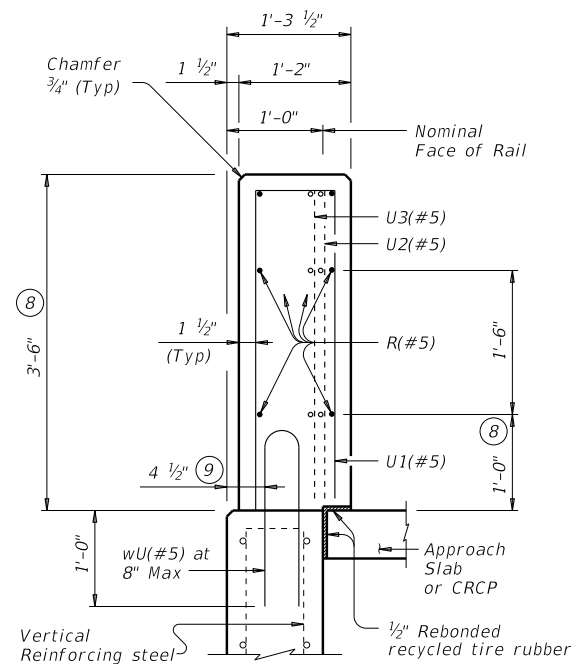

ON ABUTMENT WINGWALLS
OR CIP RETAINING WALLS

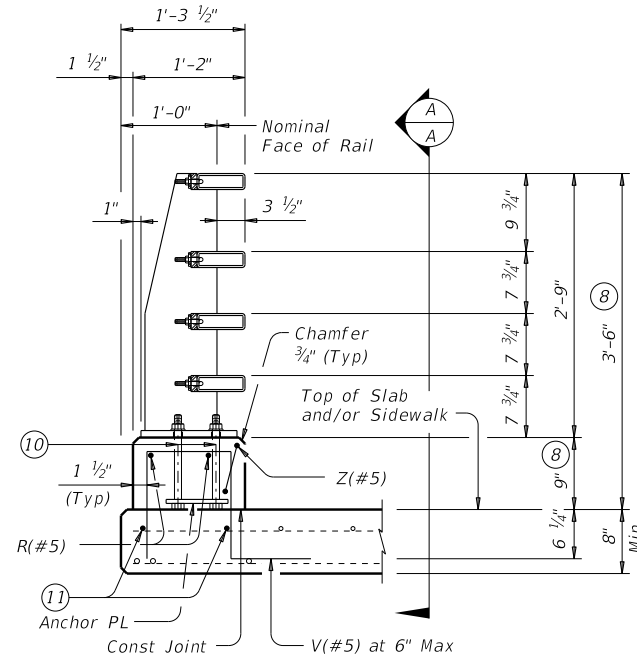

ON BRIDGE SLAB

SECTIONS THRU RAIL WITHOUT RAISED SIDEWALK

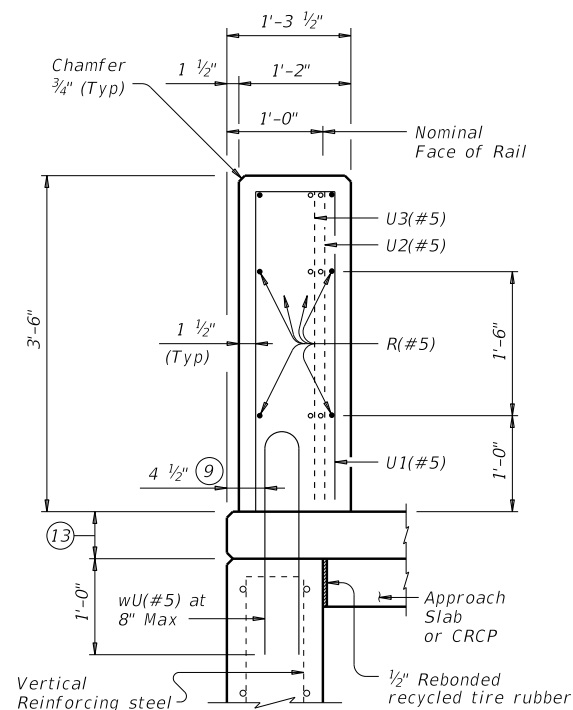

ON ABUTMENT WINGWALLS
OR CIP RETAINING WALLS

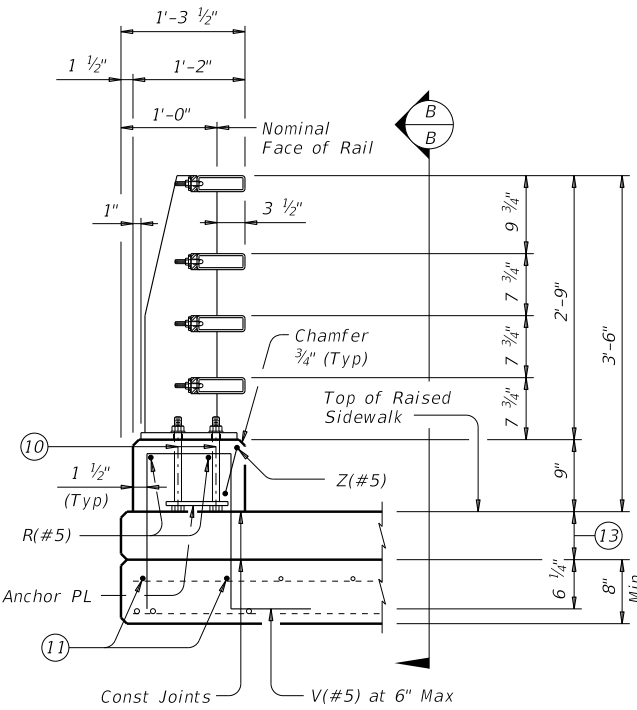

ON BRIDGE SLAB

SECTIONS THRU RAIL WITH RAISED SIDEWALK

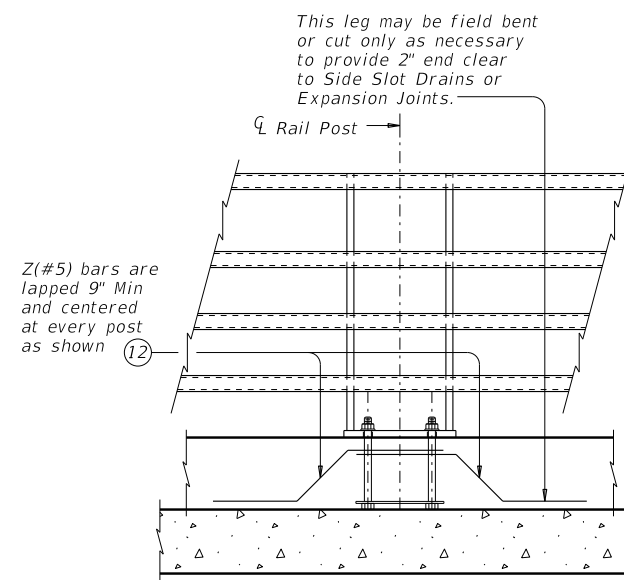

VIEW A-A

Bars V and R omitted for clarity.
Showing without raised sidewalk.

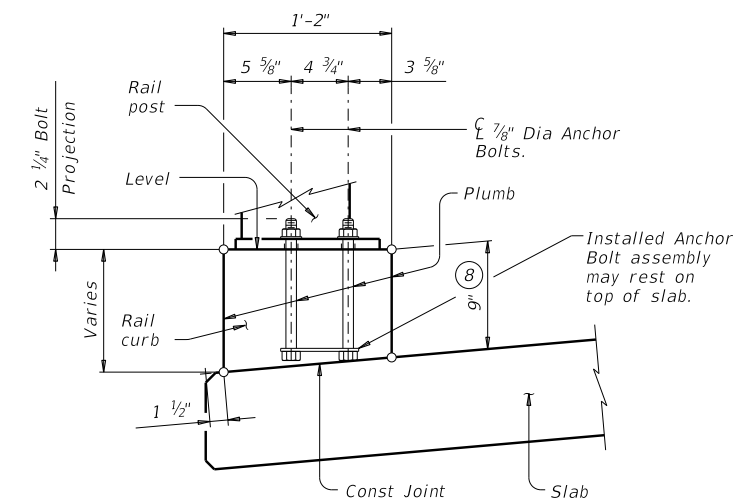

WITHOUT RAISED SIDEWALK

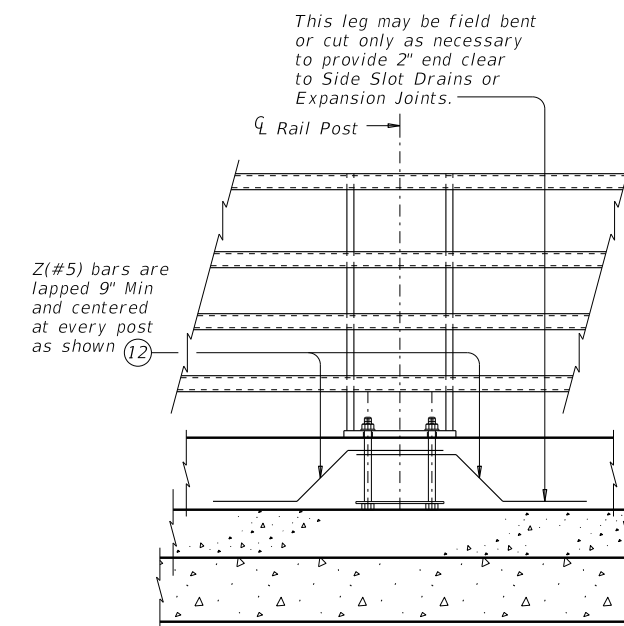

VIEW B-B

Bars V and R omitted for clarity.
Showing with raised sidewalk.

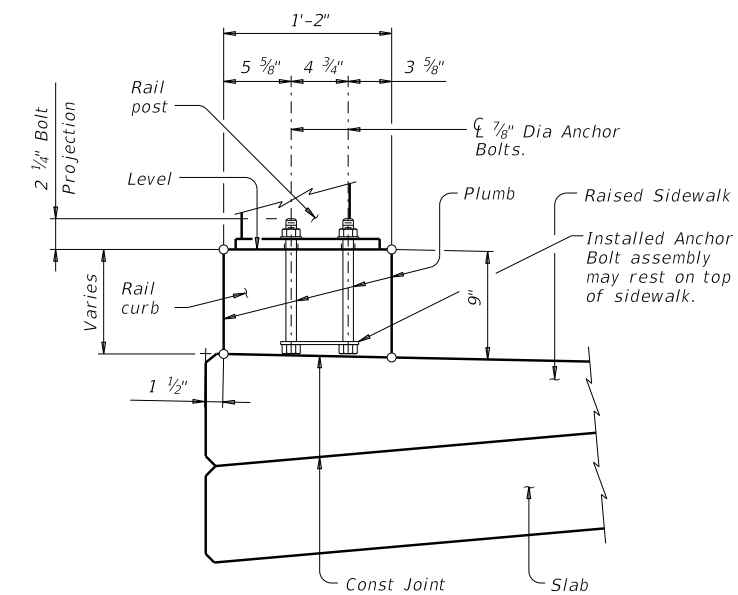

WITH RAISED SIDEWALK

RAIL CURB FORMING DETAIL
Reinforcing steel and rail curb chamfers not shown for clarity.

- ⑧ Increase 2" for structures with Overlay.
- ⑨ 5 1/4" when vertical reinforcing has closer clear cover over horizontal reinforcing in abutment wingwalls or retaining walls on traffic side of wall.
- ⑩ 7/8" Dia Anchor Bolts. See "Anchor Bolt Assembly Details."
- ⑪ Top longitudinal slab bar may be adjusted laterally 3" plus or minus to tie reinforcing.
- ⑫ Adjust Bars Z(#5) as necessary to avoid Bars V(#5).
- ⑬ Raised Sidewalk.

SHEET 2 OF 4



COMBINATION RAIL

TYPE CIW

FILE: RL-CIW-19.dgn	DN: TxDOT	CK: TxDOT	DW: JTR	CK: JMH
©TxDOT September 2019 REVISIONS	CONT	SECT	JOB	HIGHWAY
	DIST	COUNTY	SHEET NO.	

DATE:
FILE:

DISCLAIMER: The use of this standard is governed by the "Texas Engineering Practice Act." No warranty of any kind is made by TxDOT for any purpose whatsoever. TxDOT assumes no responsibility for the conversion of this standard to other formats or for incorrect results or damages resulting from its use.

DATE: FILE:

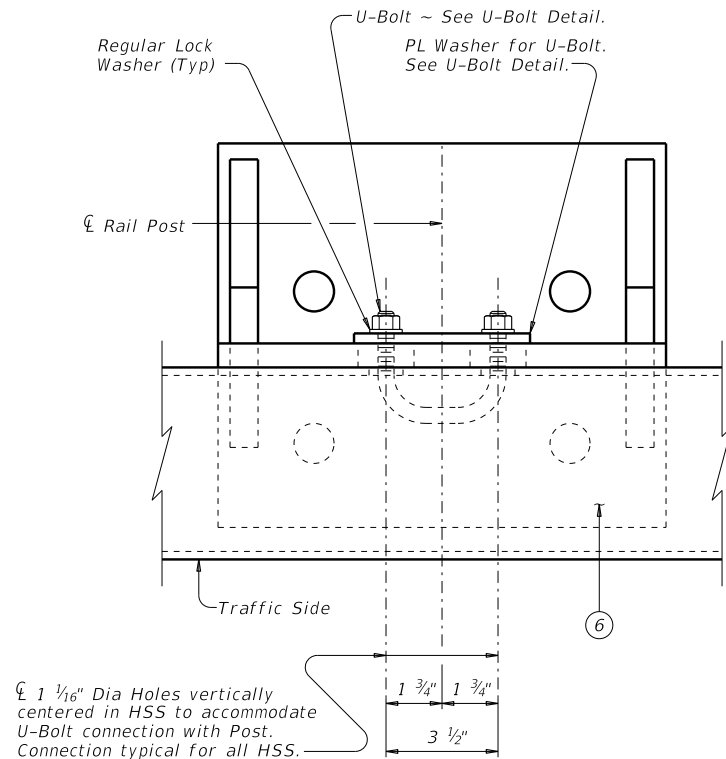
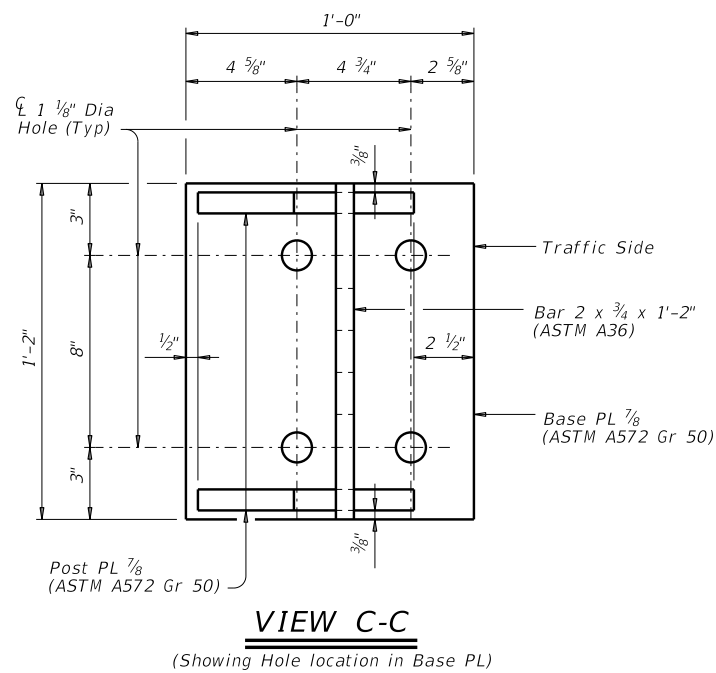
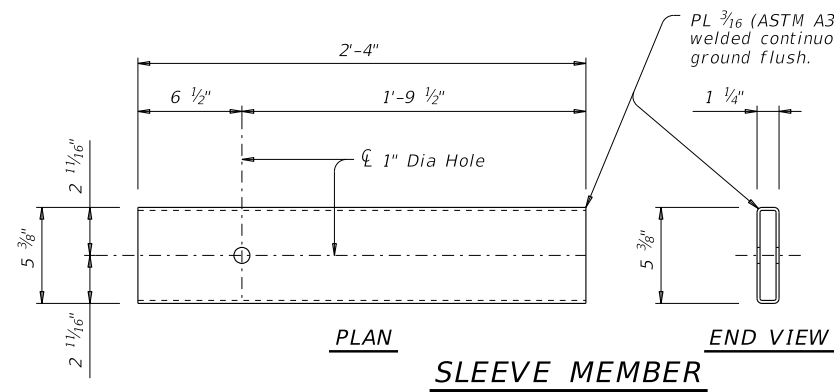

TOP VIEW OF RAIL POST
(Showing connection for rail post and HSS.)

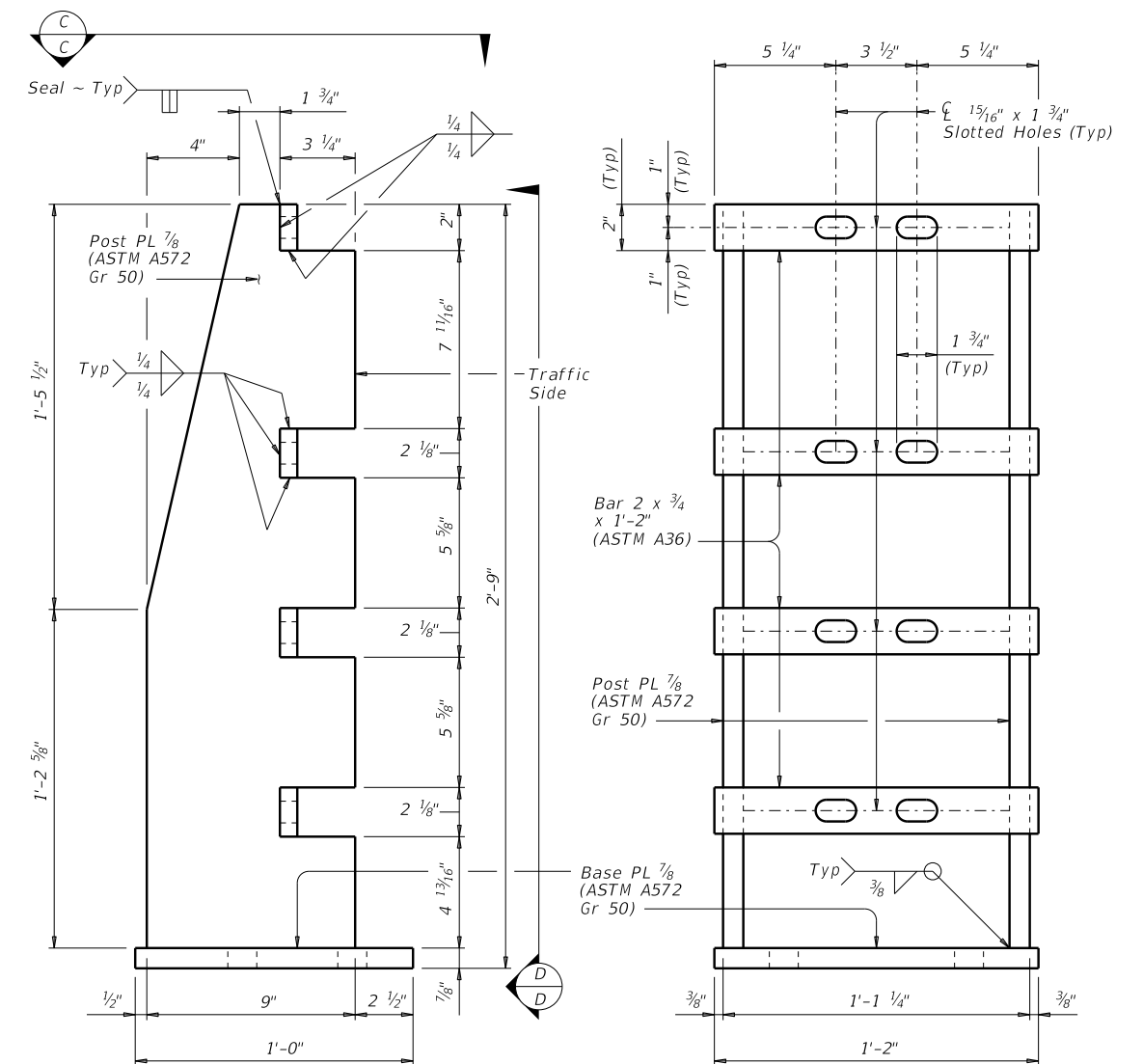

POST DETAIL

VIEW D-D

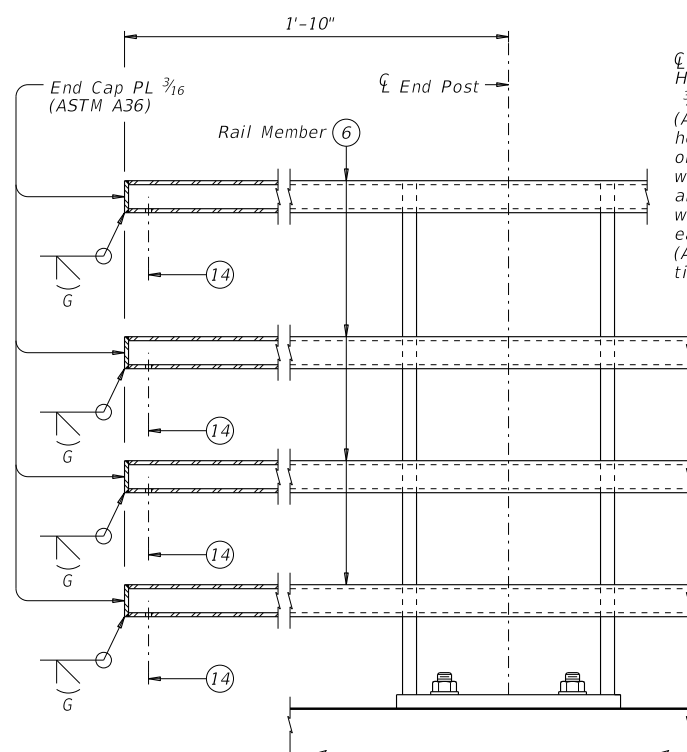

END CAPS ON HSS AT END POST

1" Dia holes in HSS centered for 3/4" Dia x 3 1/2" hex head bolts with one hardened steel washer (ASTM F436) and one regular lock washer placed under each heavy hex nut (ASTM A563). Wrench tight, do not crush rail.

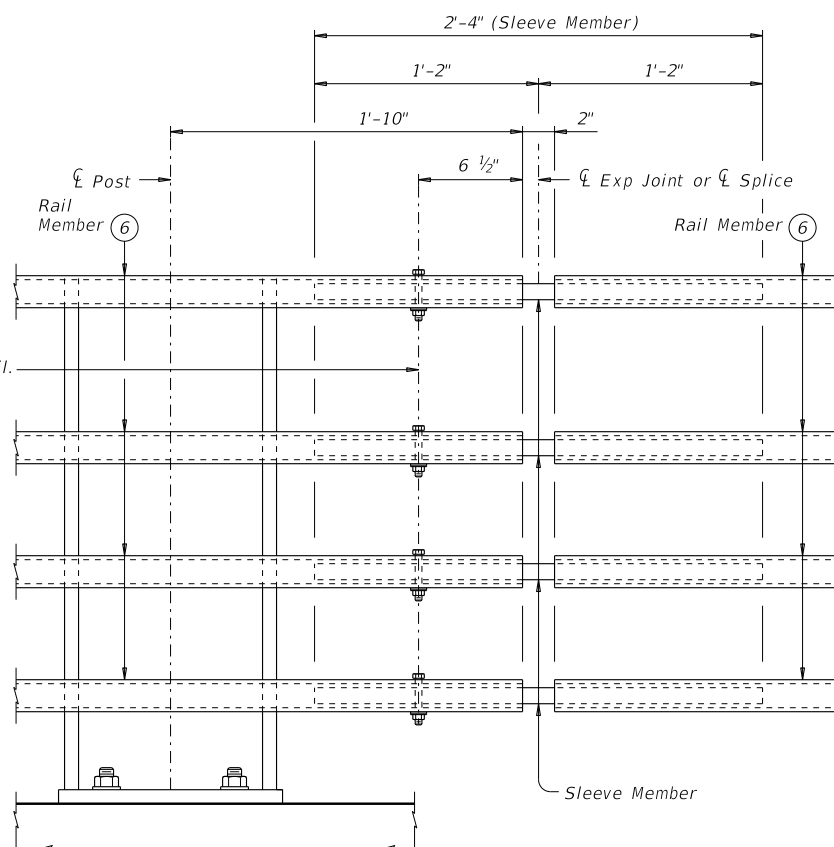

EXPANSION JOINT OR SPLICE

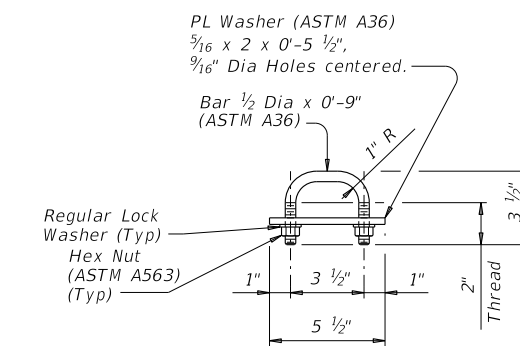

U-BOLT DETAIL
(Showing U-Bolt for rail post and HSS.)

- 6 HSS 6 x 2 x 1/4 (ASTM A1085 or A500 Grade B).
- 14 3/8" Dia Drain Hole in bottom of HSS.

SHEET 3 OF 4

		Bridge Division Standard	
<h2>COMBINATION RAIL</h2>			
<h3>TYPE CIW</h3>			
FILE: RL-CIW-19.dgn	DN: TxDOT	CK: TxDOT	DW: JTR
©TxDOT September 2019	CONT	SECT	JOB
REVISIONS		HIGHWAY	
DIST		COUNTY	
		SHEET NO.	

DISCLAIMER: The use of this standard is governed by the "Texas Engineering Practice Act." No warranty of any kind is made by TxDOT for any purpose whatsoever. TxDOT assumes no responsibility for the conversion of this standard to other formats or for incorrect results or damages resulting from its use.

DATE: FILE:

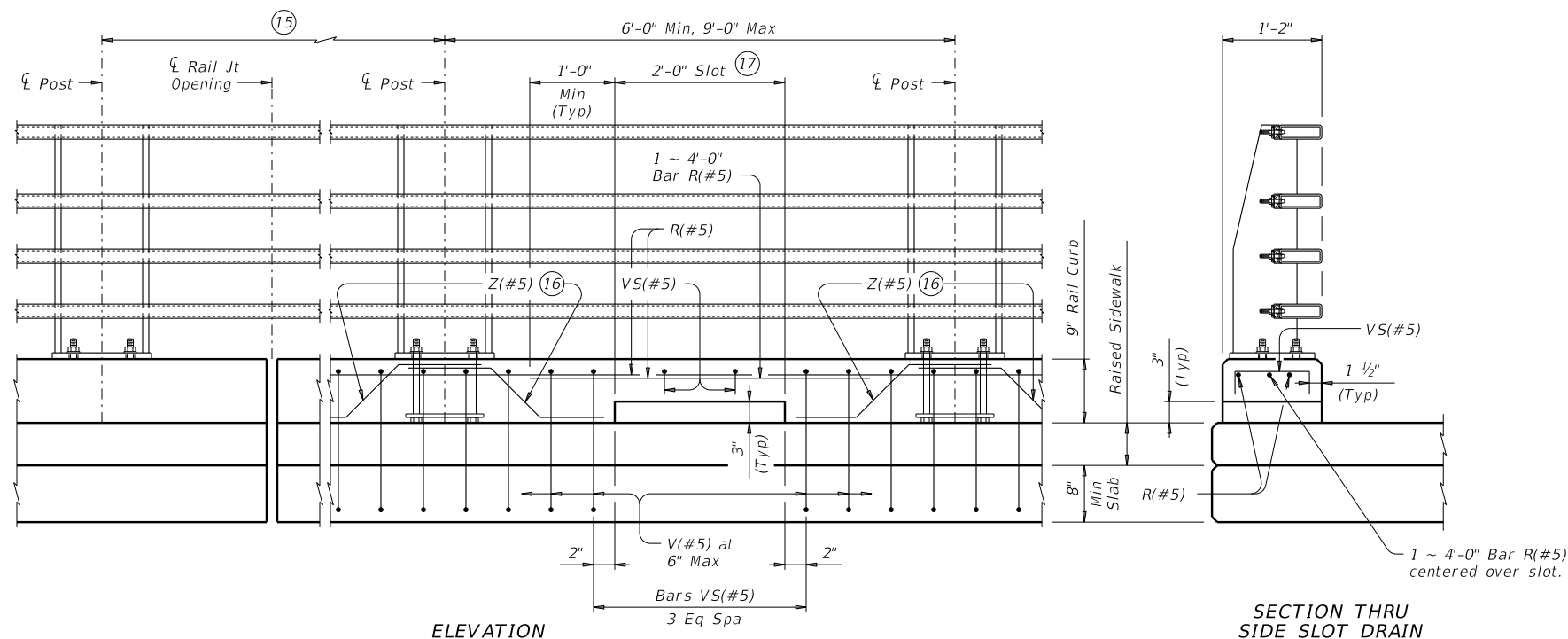

ELEVATION

SECTION THRU SIDE SLOT DRAIN

OPTIONAL SIDE SLOT DRAIN DETAILS (18)

Showing side slot drain on raised sidewalk, without raised sidewalk similar.

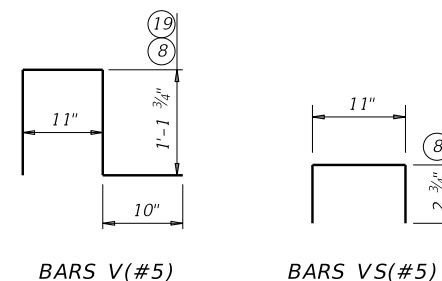

BARS V(#5)

BARS VS(#5)

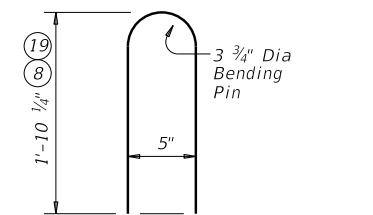

BARS wU(#5)

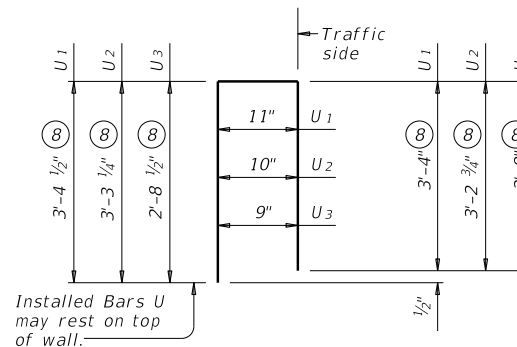

BARS U(#5)

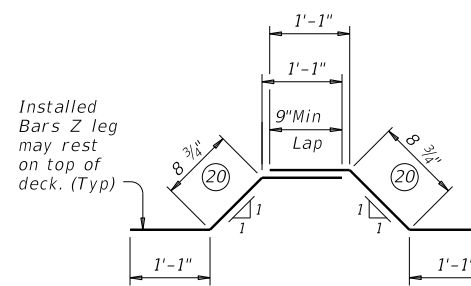

BARS Z(#5)

CONSTRUCTION NOTES:

The face of tubular sections and rail curb must be plumb unless otherwise approved by the Engineer. Steel posts must be square to the top of curb. Use Type VIII epoxy mortar under post base plates if gaps larger than 1/16" exist. Bend tubes to required radius for curved rails. Shop drawings for approval are required for curved rails. One shop splice per rail member section is permitted with minimum 85 percent penetration. The weld may be square groove or single V groove. Grind smooth. Round or chamfer exposed edges of rail members and rail posts must be rounded or chamfered to approximately 1/16" by grinding. Chamfer all exposed concrete corners.

MATERIAL NOTES:

Provide ASTM A1085 or A500 Gr B for all HSS. Provide Grade 60 reinforcing steel. Epoxy coat or galvanize all reinforcing steel if slab bars are epoxy coated or galvanized. Galvanize all metal components of steel rail system. Apply additional coatings when shown elsewhere on the plans. When plans require paint over galvanizing, follow the requirements for painting galvanized steel in Item 445, "Galvanizing" and when field painting, Item 446, "Field Cleaning and Painting Steel." Sleeve members and anchor bolts must receive galvanization prior to installation and only field paint after installation unless directed otherwise by Engineer. Provide 7/8" Dia ASTM F3125 Gr A325 or A449 bolts (or ASTM A193 Gr B7 or F1554 Gr 105 threaded rods with one tack welded heavy hex nut each) with one hardened steel washer (ASTM F436) placed under each heavy hex nut that conforms to ASTM A563 requirements. Provide 1/2" Dia round bar U-bolts (ASTM A36) with plate washer (ASTM A36) and regular lock washers placed under hex nuts that conform to ASTM A563 requirements. See "U-Bolt Detail." Provide Class "S" concrete. When Class "S" concrete for slab is HPC, include a minimum of 3 gallons of calcium nitrite inorganic corrosion inhibitor per cubic yard of Class "S" concrete. Provide bar laps, where required, as follows:
Uncoated or galvanized ~ #5 = 2'-0"
Epoxy coated ~ #5 = 3'-0"

GENERAL NOTES:

This rail has been successfully evaluated by full-scale crash test to meet MASH TL-4 criteria. This rail can be used for speeds of 50 mph and greater when a TL-3 rated guard fence transition is used. When a TL-2 rated guard fence transition is used, this rail can only be used for speeds of 45 mph and less. This railing cannot be used on bridges with expansion joints providing more than 5" movement or on cast-in-place retaining walls, unless otherwise noted. Rail anchorage details shown on this standard may require modification for select structure types. See appropriate details elsewhere in plans for these modifications. Submit erection drawings showing panel lengths, rail post spacing, and anchor bolt setting, to the Engineer for approval. Average weight of railing with no overlay:
205 plf total
131 plf (Conc)
74 plf (Steel).

Cover dimensions are clear dimensions, unless noted otherwise. Reinforcing bar dimensions shown are out-to-out of bar.

		Bridge Division Standard	
<h2>COMBINATION RAIL</h2>			
<h3>TYPE CIW</h3>			
FILE: RL-CIW-19.dgn	DN: TxDOT	CK: TxDOT	DW: JTR
©TxDOT September 2019	CONT	SECT	JOB
REVISIONS		HIGHWAY	
DIST		COUNTY	
		SHEET NO.	

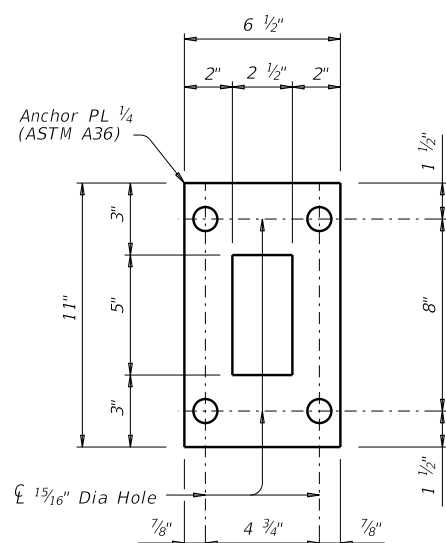

PLAN OF ANCHOR PLATE

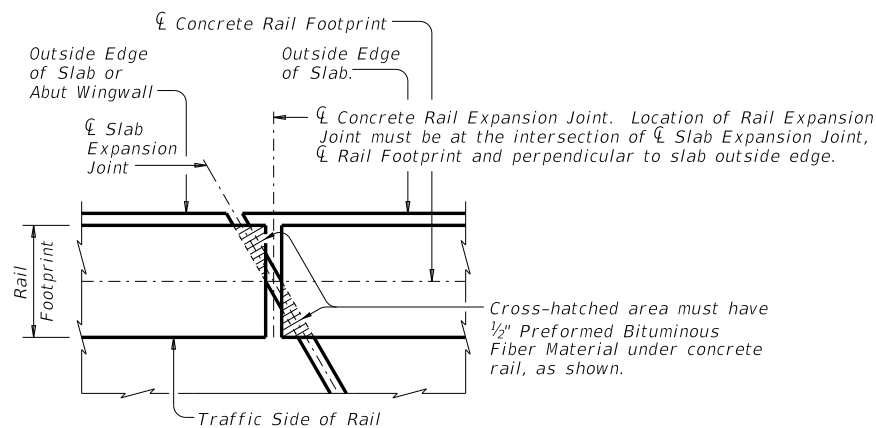

PLAN OF RAIL AT EXPANSION JOINTS

Example showing Slab Expansion Joints without breakbacks.

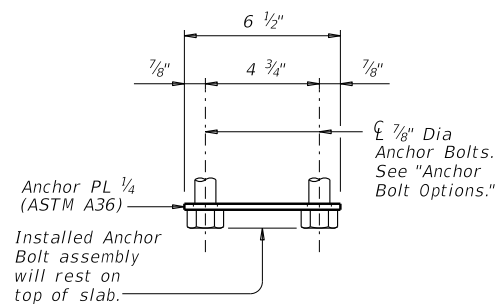

ELEVATION

ANCHOR BOLT ASSEMBLY DETAILS

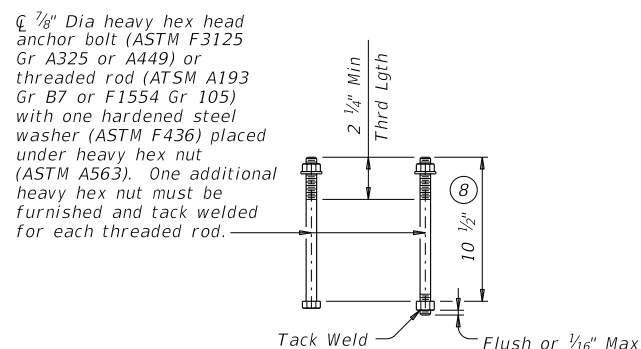

ANCHOR BOLT OPTIONS

(Showing Anchor Bolts for Base Plate)

- (8) Increase 2" for structures with Overlay.
- (15) Side slot drains are not allowed in areas where there is a joint in the concrete curb between rail posts.
- (16) Bars Z(#5). See "Section Thru Rail" and "View A-A or B-B" for Bar Z placement and spacing.
- (17) Center side slot drain between posts within the limits shown.
- (18) Side slot drains may be used where shown elsewhere on the plans or as directed by the Engineer. Do not place drains over railroad tracks, lower roadways, or sidewalks. When this rail is used as a separator between a roadway and a sidewalk, side slot drains are not permitted.
- (19) For raised sidewalks, add sidewalk height to total bar height. Use sidewalk height at rail's location.
- (20) Increase 2 3/4" for structures with Overlay.