

DISCLAIMER: The use of this standard is governed by the "Texas Engineering Practice Act." No warranty of any kind is made by TxDOT for any purpose whatsoever. TxDOT assumes no responsibility for the conversion of this standard to other formats or for incorrect results or damages resulting from its use.

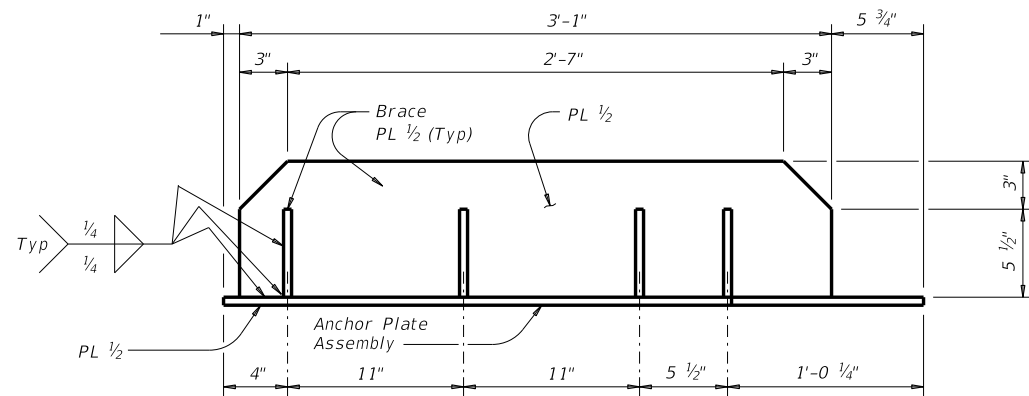

PLAN

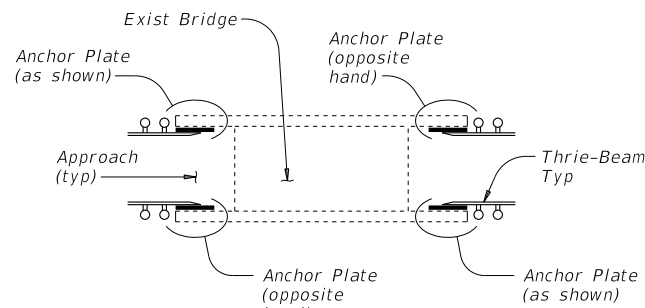

LOCATION DETAILS

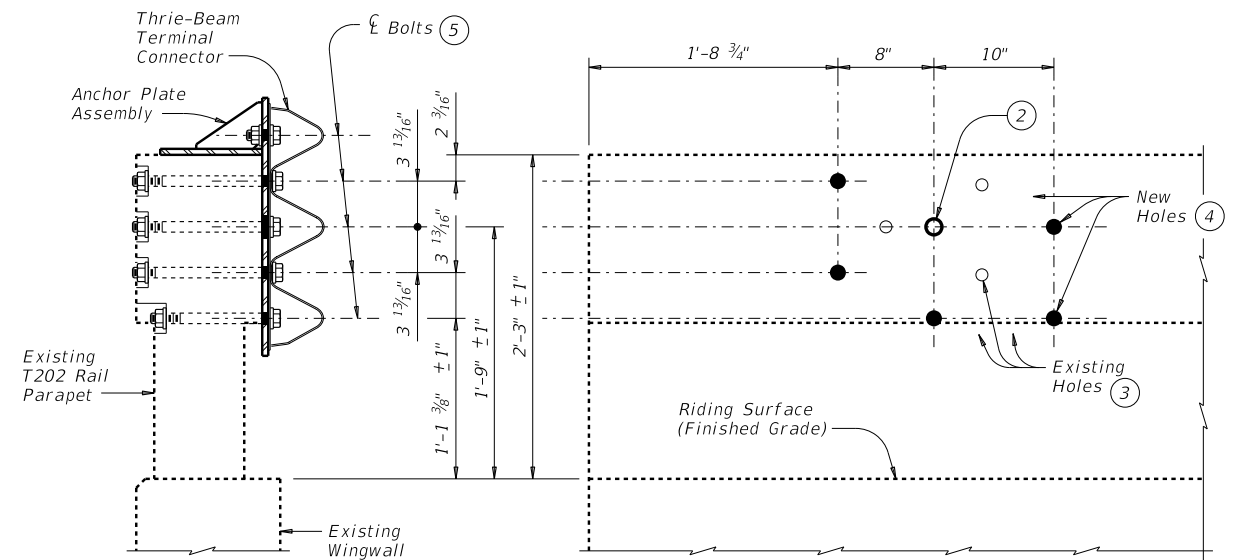

SECTION

Showing completed installation

ROADSIDE ELEVATION

Anchor Plate assembly and Thrie-Beam Terminal Connector not shown for clarity

DETAILS OF BOLTS AND HOLES ①

CONSTRUCTION NOTES:

Field verify dimensions before commencing work and ordering materials. Plugging of newly exposed existing bolt holes is not necessary except as stated here in or otherwise indicated on the plans. This work is considered subsidiary to the pertinent bid items.

Attach the MBGF Transition to the existing parapet using the Anchor Plate assembly and the Thrie-Beam Terminal Connector. Splice the Thrie-Beam Terminal Connector to the Thrie-Beam with the normal 12 connection bolts. Refer to Metal Beam Guard Fence Transition and Metal Beam Guard Fence detail sheets for additional details and information not shown herein.

MATERIAL NOTES:

Fabricate Anchor Plate assembly with steel conforming to either ASTM A36 or A572 Gr 50. Anchor Plate assembly must be free of burrs, sharp edges and weld splatter. Grind edges and corners to a 1/16" flat or radius. Hot-dip galvanize Anchor Plate assembly in accordance with Item 445, "Galvanizing." Anchor bolts, nuts, and washers must conform to Item 449, "Anchor Bolts."

GENERAL NOTES:

These details are for retrofitting existing rails only, not new construction, with a Thrie-Beam Terminal Connector.

Shop drawings are not required for this installation. Payment for materials, fabrication, and installation of this assembly are to be included in unit price bid in accordance with Item 540 "Mtl Bm Gd Fen Trans (Anchor Plate)."

Estimated weight of a single Anchor Plate assembly, including bolts, nuts, and washers, but not including the Thrie-Beam Terminal Connector = 190 Lbs.

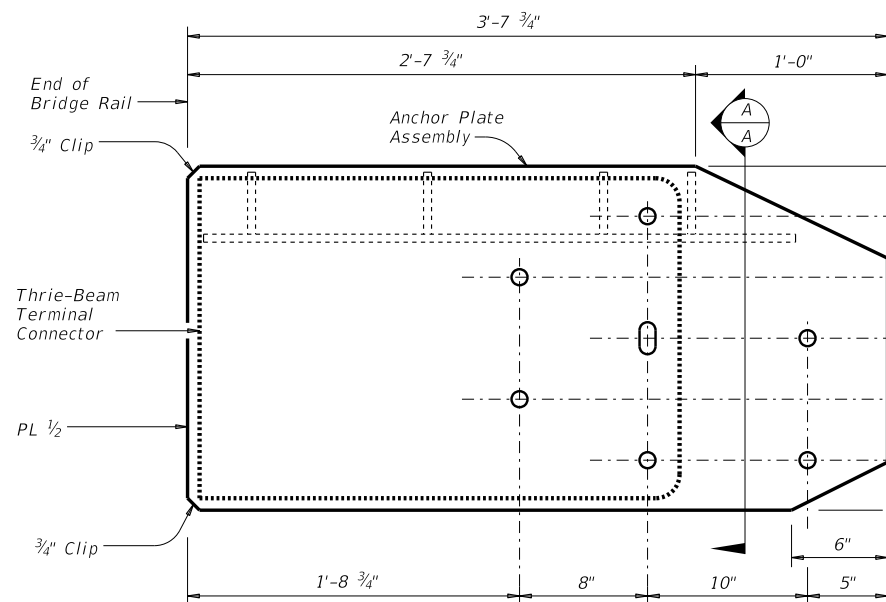

ROADSIDE ELEVATION

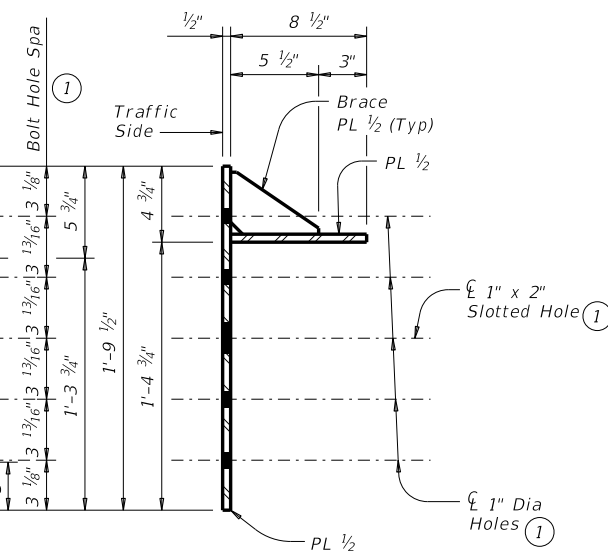

SECTION A-A

ANCHOR PLATE DETAILS

Anchor Plate shown is detailed for one end of one side of rail only. For other side, Anchor Plate must be built opposite hand.

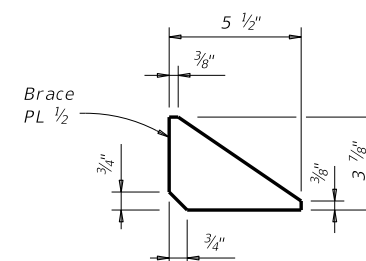

BRACE PLATE DETAILS

This sheet is intended as a guide in preparing job-specific details to retrofit existing T202 rails with a Thrie-Beam terminal connector. This sheet may not be used without modification. The details shown may need to be amended if the exact existing conditions are not covered. In all cases, details and notes not required are to be removed or crossed out, "(MOD)" added, and the phrase "(Not to be used as a standard)" removed from the title block. This sheet must be signed, sealed, and dated by a registered Professional Engineer. The effective height of the existing rail (at the Anchor Plate location) above the finished riding surface, as seen by an errant vehicle, must be between 2'-2" and 2'-4". Alternate methods of retrofit must be used for effective heights beyond these limits. Dimensions of existing rail height (traffic side) should be shown. Particular care should be taken in identifying existing rail conditions and providing for proper Anchorage Plate and MBGF transition positioning.

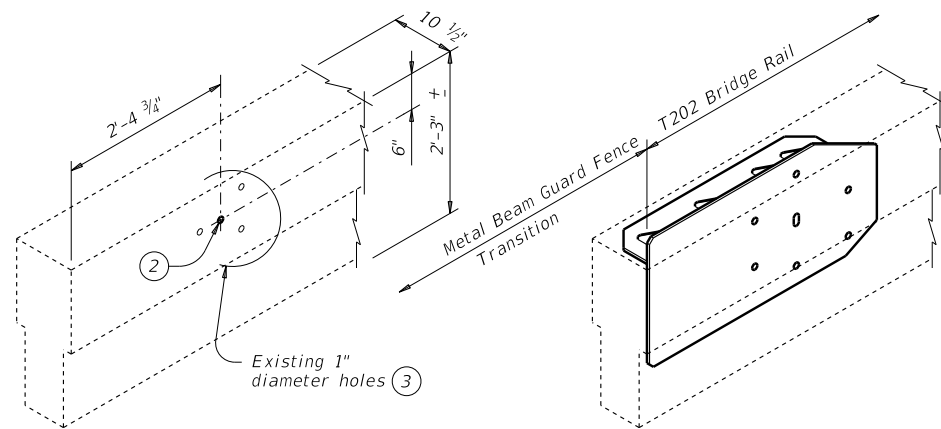

EXISTING PARAPET

Shown after removal of existing MBGF Transition connector and prior to coring new bolt holes

ANCHOR PLATE PLACEMENT

INSTALLATION DETAILS

- ① The Contractor must verify that locations of bolt holes match those in the Thrie-Beam Terminal Connector to be installed in that location prior to fabrication of the Anchor Plate assembly and prior to coring bolt holes in the existing T202 parapet.
- ② If the existing holes are aligned as expected, use the indicated existing 1" diameter hole in the installation of the Anchor Plate assembly and the Thrie-Beam Terminal Connector.
- ③ If the existing holes are not aligned as expected, holes that cannot be utilized in the installation and are within 3" of a new bolt hole must be filled with epoxy grout prior to coring new holes.
- ④ Drill new 1" diameter holes, each with a 2 1/2" diameter x 1" deep recess, through existing railing parapet. Recesses are only required when pedestrian sidewalks are adjacent to back of rail unless directed otherwise by the Engineer. Holes should be perpendicular to the roadside face of the parapet. Drill holes and recesses with coring type equipment. Percussion drilling is not allowed. Patch spalls, when directed by the Engineer, in accordance with Item 429, "Concrete Structure Repair", at the contractor's expense.
- ⑤ 7 ~ 7/8" diameter ASTM F3125 Gr A325 Hex Head Anchor Bolts each with 2 ~ 1 3/4" O.D. washers. Place washer under each head and nut. Provide bolts of sufficient length to extend a minimum of 1/2" beyond nut. Cut excess bolt length and paint cut surface with zinc-rich paint if directed by the Engineer.

		<b>Bridge Division Standard</b>	
<h2>T202 TRANSITION RETROFIT GUIDE</h2> <p>(Not to be used as a standard)</p> <h3>T202TR</h3>			
FILE: RL-T202TR-19.dgn	DN: TxDOT	CK: TxDOT	DW: TxDOT
©TxDOT	September 2019	CONT	SECT
REVISIONS		JOB	HIGHWAY
DIST	COUNTY	SHEET NO.	

DATE: FILE: