

DISCLAIMER: This standard is governed by the "Texas Engineering Practice Act". No warranty of any kind is made by TxDOT for any purpose whatsoever. TxDOT assumes no responsibility for the conversion of this standard to other formats or for incorrect results or damages resulting from its use.

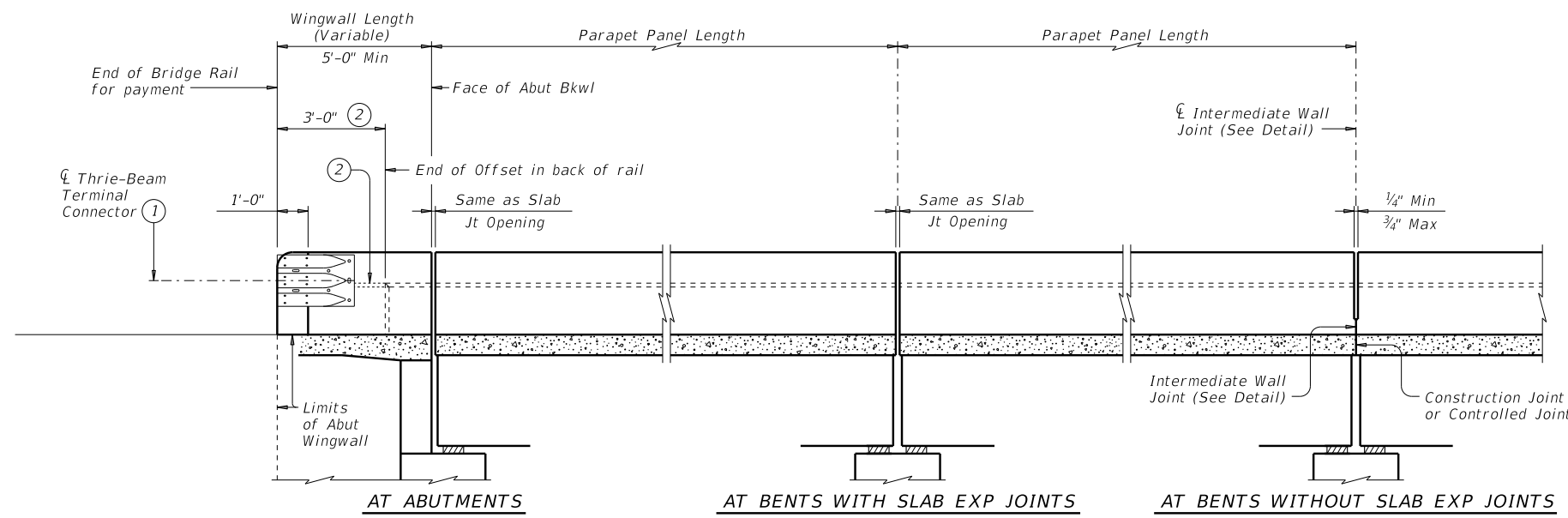

ROADWAY ELEVATION OF RAIL

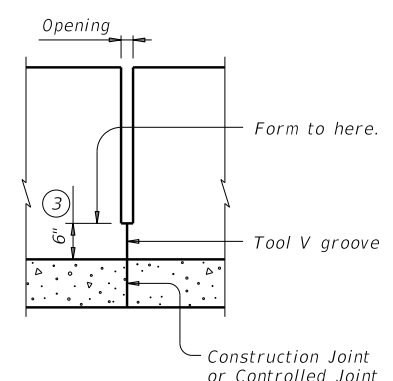

INTERMEDIATE WALL JOINT DETAIL
Provide at all interior bents without slab expansion joints.

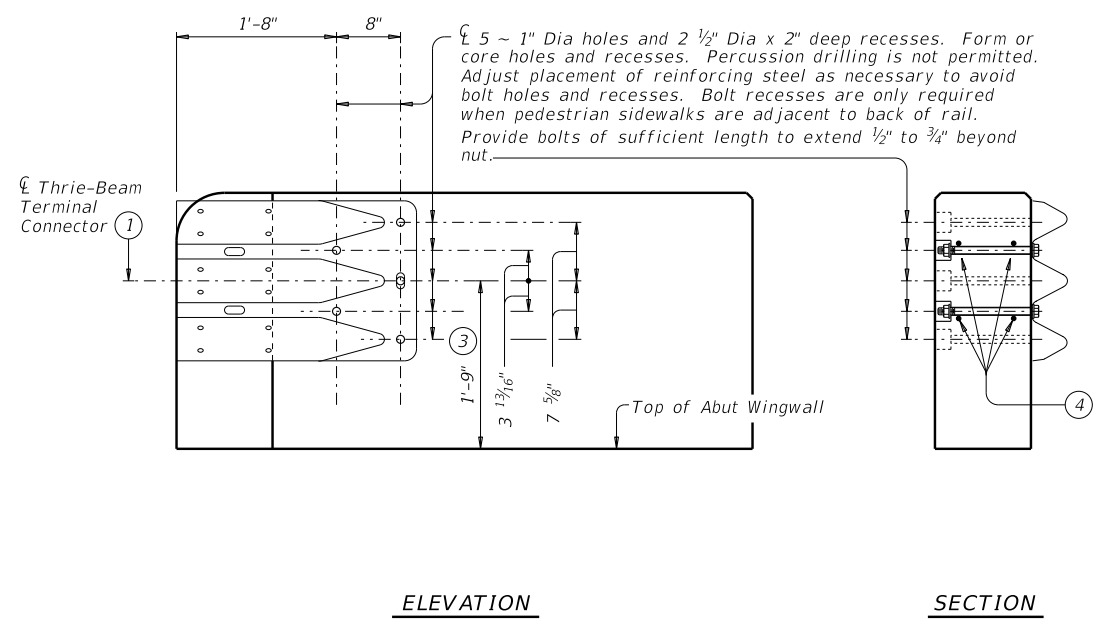

TERMINAL CONNECTION DETAILS

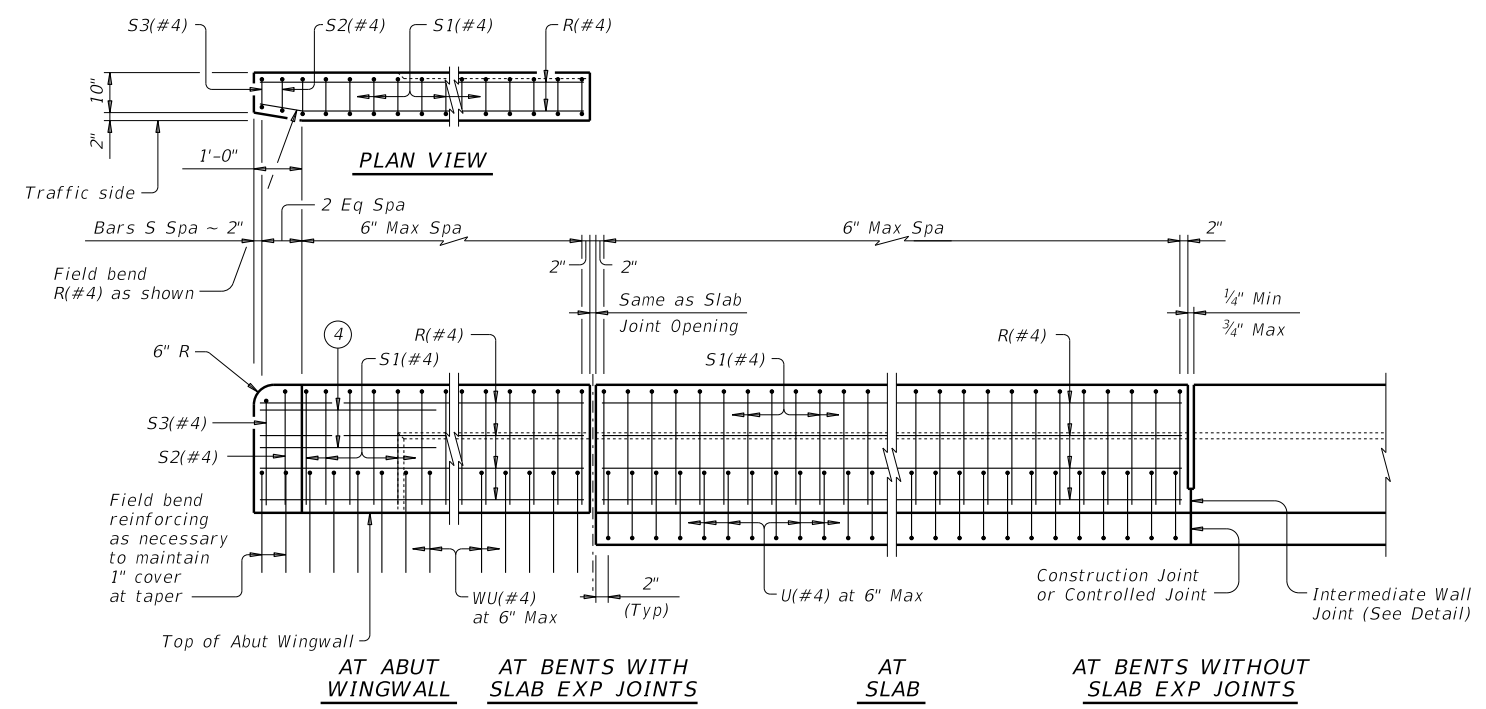

ELEVATION SHOWING TYPICAL REINFORCING PLACEMENT

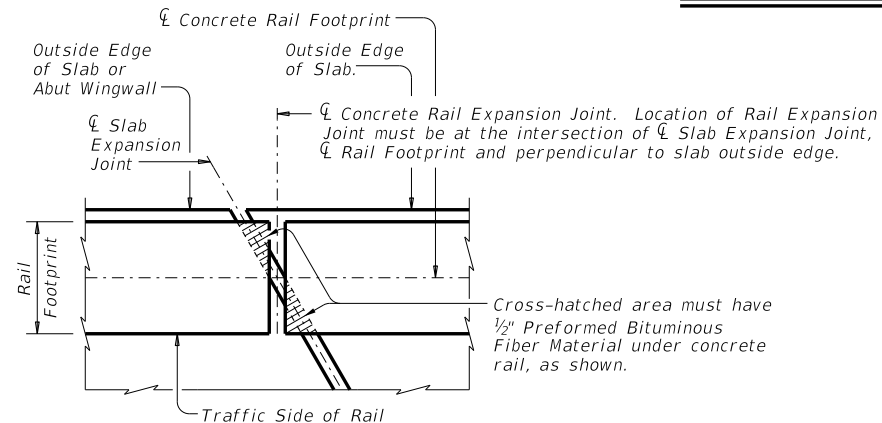

PLAN OF RAIL AT EXPANSION JOINTS
Example showing Slab Expansion Joints without breakbacks.

- ① Terminal Connectors and associated hardware are to be paid for under the Item "Metal Beam Guard Fence". Attach Metal Beam Guard Fence Transitions to the bridge rail and extend along the embankment unless otherwise shown in the plans.
- ② Back of rail offset may, with Engineer's approval, be continued to the end of the railing.
- ③ Increase 2" for structures with overlay.
- ④ Place 4 additional Bars R(#4) 3'-8" in length inside Bars S(#4) and centered 2'-0" from end of rail when Terminal Connections are required. Field bend as needed.

SHEET 1 OF 2

Texas Department of Transportation
Bridge Division Standard

TRAFFIC RAIL

TYPE T221

FILE: RL-T221-19.dgn	DN: TxDOT	CK: TxDOT	DW: JTR	CK: TxDOT
©TxDOT September 2019	CONT	SECT	JOB	HIGHWAY
REVISIONS				
DIST	COUNTY			SHEET NO.

DATE:
FILE:

DISCLAIMER: The use of this standard is governed by the "Texas Engineering Practice Act". No warranty of any kind is made by TxDOT for any purpose whatsoever. TxDOT assumes no responsibility for the conversion of this standard to other formats or for incorrect results or damages resulting from its use.

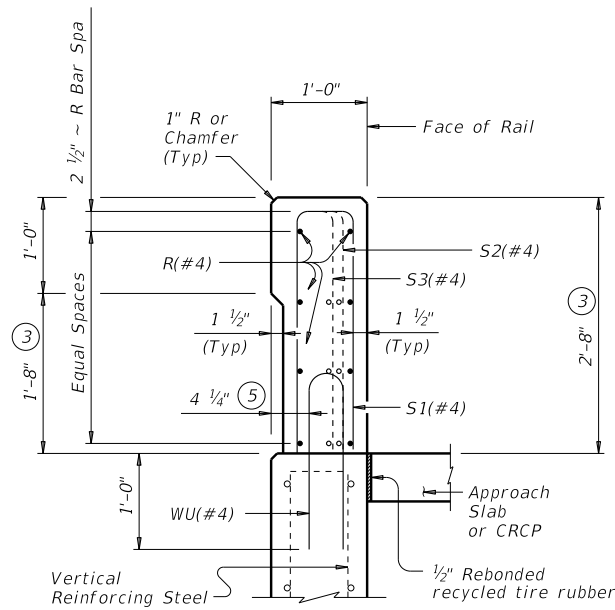

ON ABUTMENT WINGWALLS OR CIP RETAINING WALLS

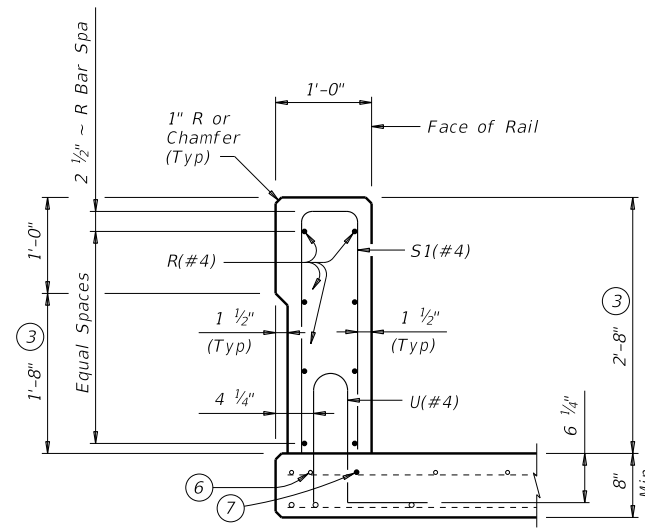

ON BRIDGE SLAB

SECTIONS THRU RAIL

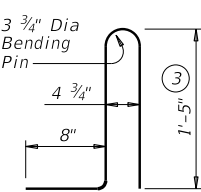

BARS U (#4)

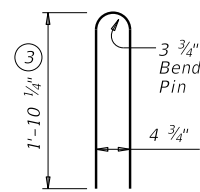

BARS WU (#4)

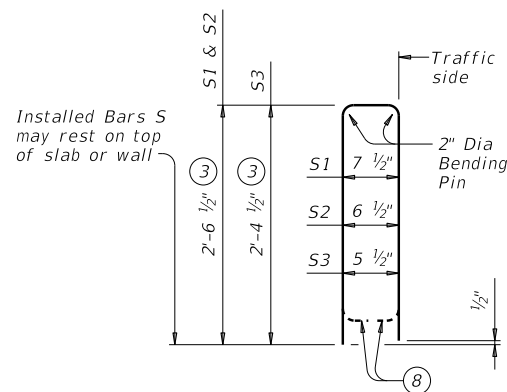

BARS S (#4)

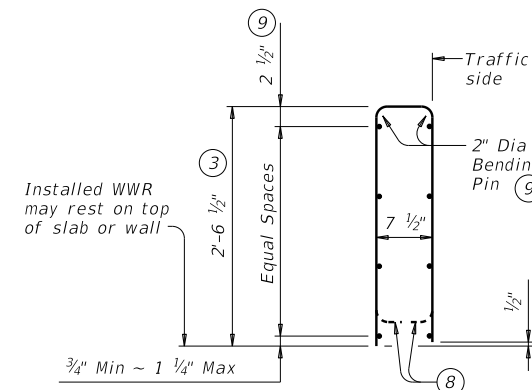

OPTIONAL WELDED WIRE REINFORCEMENT (WWR)

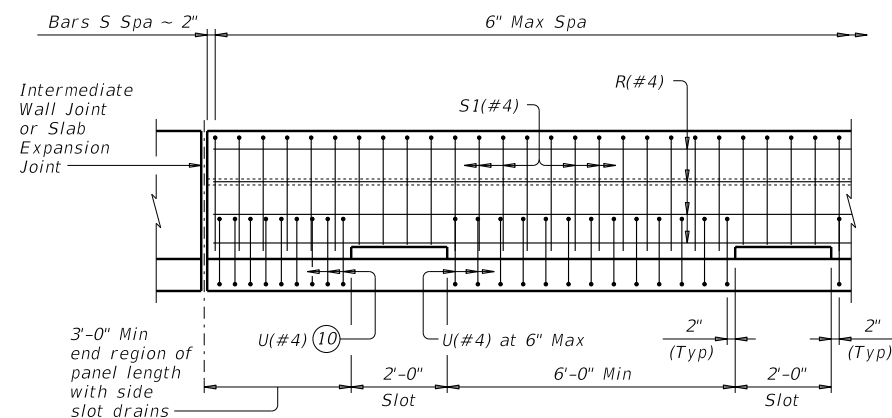

OPTIONAL SIDE SLOT DRAIN DETAIL

Note: Side Slot Drains may be used where shown elsewhere on the plans or as directed by the Engineer. Drains should not be placed over railroad tracks, lower roadways, or sidewalks. When this rail is used as a separator between a roadway surface and a sidewalk surface, side drain slots will not be permitted.

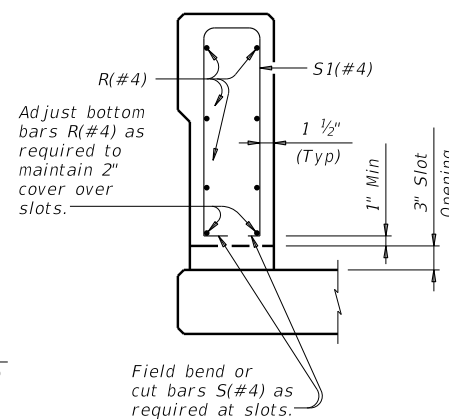

SECTION THRU OPTIONAL SIDE SLOT DRAIN

- ③ Increase 2" for structures with overlay.
- ⑤ 5 1/4" when vertical reinforcing has closer clear cover over horizontal reinforcing in abutment wingwalls or retaining walls on traffic side of wall.
- ⑥ As an aid in supporting reinforcement, additional longitudinal bars may be used in the slab with the approval of the Engineer. Such bars will be furnished at the Contractor's expense.
- ⑦ Top longitudinal slab bar may be adjusted laterally 3" plus or minus to tie reinforcing.
- ⑧ Bend or cut as required to clear drain slots.
- ⑨ No longitudinal wires may be in top center of cage.
- ⑩ Space U(#4) bars at 4" Max when end region of panel length is less than 6'-0" to side slot drain. Space U(#4) bars at 6" Max when end region of panel length is 6'-0" and greater to side slot drain.

CONSTRUCTION NOTES:

This railing may be constructed by the slipform process when approved by the Engineer, with equipment approved by the Engineer. Provide sensor control for both line and grade. Tack welding to provide bracing for slipform operations is acceptable. Welding may be performed at a minimum spacing of 3 ft between the cage and the anchorage. It is permissible to weld to bars U, WU and S at any location on the cage. If increased bracing is needed, provide additional anchorage devices and weld in the upper two thirds of the cage. Paint welded areas on epoxy coated and/or galvanized reinforcing with an organic zinc rich paint in accordance with Item 445 "Galvanizing".
If rail is slipformed, apply an heavy epoxy bead 1" behind toe of traffic side of rail to concrete deck just prior to slip forming. Provide a 3/8" width x 1/4" tall heavy epoxy bead with Type III, Class C or a Type V epoxy.
Face of rail and parapet must be vertical transversely unless otherwise shown in the plans or approved by the Engineer.
Chamfer all exposed concrete corners.

MATERIAL NOTES:

Provide Class "C" concrete. Provide Class "C" (HPC) if required elsewhere.
Provide Grade 60 reinforcing steel.
Epoxy coat or galvanize all reinforcing steel if slab bars are epoxy coated or galvanized.
Deformed Welded Wire Reinforcement (WWR) (ASTM A1064) of equal size and spacing may be substituted for Bars U and WU unless noted otherwise. Deformed WWR (ASTM 1064) may be substituted for Bars R and S, as shown. Combinations of reinforcing steel and WWR or configurations of WWR other than shown are permitted if conditions in the table are satisfied. Provide the same laps as required for reinforcing bars.
Provide bar laps, where required, as follows:
Uncoated or galvanized ~ #4 = 1'-7"
Epoxy coated ~ #4 = 2'-5"

GENERAL NOTES:

This rail has been evaluated and accepted to be of equal strength to railings with like geometry, which have been crash tested to meet MASH TL-3 criteria. This rail can be used for speeds of 50 mph and greater when a TL-3 rated guard fence transition is used. When a TL-2 rated guard fence transition is used, this rail can only be used for speeds of 45 mph and less.
Do not use this railing on bridges with expansion joints providing more than 5" movement.
Rail anchorage details shown on this standard may require modification for select structure types. See appropriate details elsewhere in plans for these modifications.
Shop drawings are not required for this rail.
Average weight of railing with no overlay is 370 plf.

Cover dimensions are clear dimensions, unless noted otherwise. Reinforcing bar dimensions shown are out-to-out of bar.

DESCRIPTION	LONGITUDINAL WIRES	VERTICAL WIRES
Minimum (Cumulative Total) Wire Area	1.067 Sq In.	0.267 Sq In. per Ft
Minimum	No. of Wires	Spacing
Maximum	8	4"
Maximum Wire Size Differential	10	8"
	The smaller wire must have an area of 40% or more of the larger wire.	

		Bridge Division Standard	
<h1>TRAFFIC RAIL</h1>			
<h2>TYPE T221</h2>			
FILE: RL-T221-19.dgn	DN: TxDOT	CK: TxDOT	DW: JTR
©TxDOT September 2019	CONT	SECT	JOB
REVISIONS		HIGHWAY	
DIST	COUNTY	SHEET NO.	