

DISCLAIMER: The use of this standard is governed by the "Texas Engineering Practice Act". No warranty of any kind is made by TxDOT for any purpose whatsoever. TxDOT assumes no responsibility for the conversion of this standard to other formats or for incorrect results or damages resulting from its use.

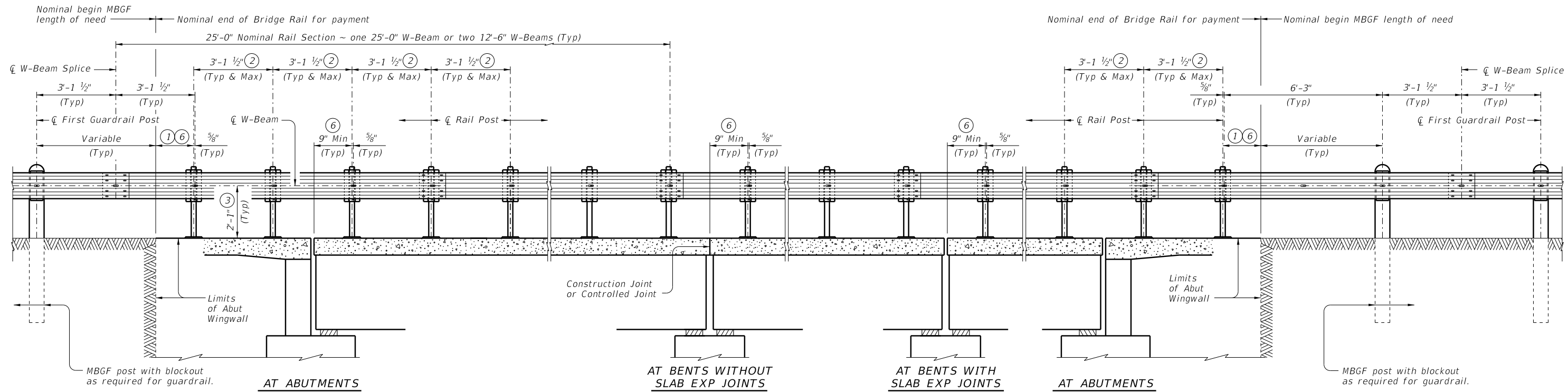

- ① 9" Min, 5'-9" Max
- ② Maintain 3'-1 1/2" Rail Post spacing wherever possible for use with nominal 25'-0" or 12'-6" W-Beam sections. Symmetry of post spacing on both sides and along the structure is not necessary.
- ③ Increase 2" for structures with overlay.
- ④ Tighten the first hex nut by hand until the top and bottom edges of the W-Beam engage the Backer Plate (Backer Plate should be snug against the post). Then tighten hex nut one revolution with wrench and secure with the second hex nut.
- ⑤ PL 1/8" x 1 3/4" x 1 3/4" with 3/8" Dia Hole centered in PL (ASTM A36). Square Guardrail Washer (FWR01).
- ⑥ The post nearest to a slab joint or end of structure may be shifted up to 9" in order to satisfy the minimum offset dimension. Drill a new 3/4" Dia hole on the centerline of W-beam for shifted post. Paint hole with two coats of zinc-rich paint conforming to the Item "Galvanizing". All other posts must remain on the typical spacing.
- ⑦ 7/8" Dia formed holes for 3/8" Dia heavy hex head anchor bolt (ASTM F3125 Gr A325 or A449) or threaded rod (ASTM A193 Gr B7 or F1554 Gr 105) with one hardened steel washer (ASTM F436) and one regular lock washer placed under heavy hex nut (ASTM A563). One additional heavy hex nut must be furnished and tack welded for each threaded rod. See "Cast-In-Place & Formed Hole Anchor Bolt Options".
- ⑧ 3/8" Dia heavy hex head anchor bolt (ASTM F3125 Gr A325 or A449) or threaded rod (ASTM A193 Gr B7 or F1554 Gr 105) with one hardened steel washer (ASTM F436) and one regular lock washer placed under heavy hex nut (ASTM A563). One additional heavy hex nut must be furnished and tack welded for each threaded rod. See "Cast-In-Place & Formed Hole Anchor Bolt Options".

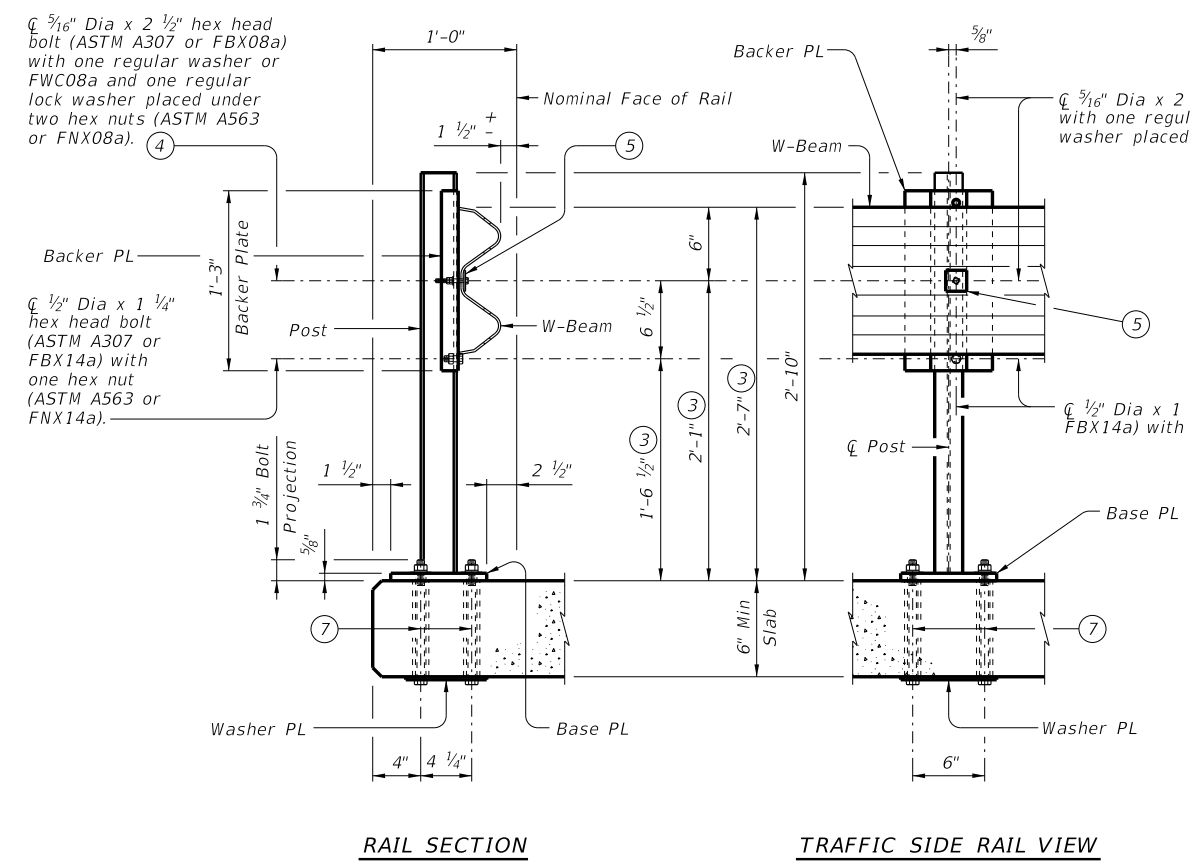

RAIL DETAILS ON BRIDGE SLAB

Showing without overlay.

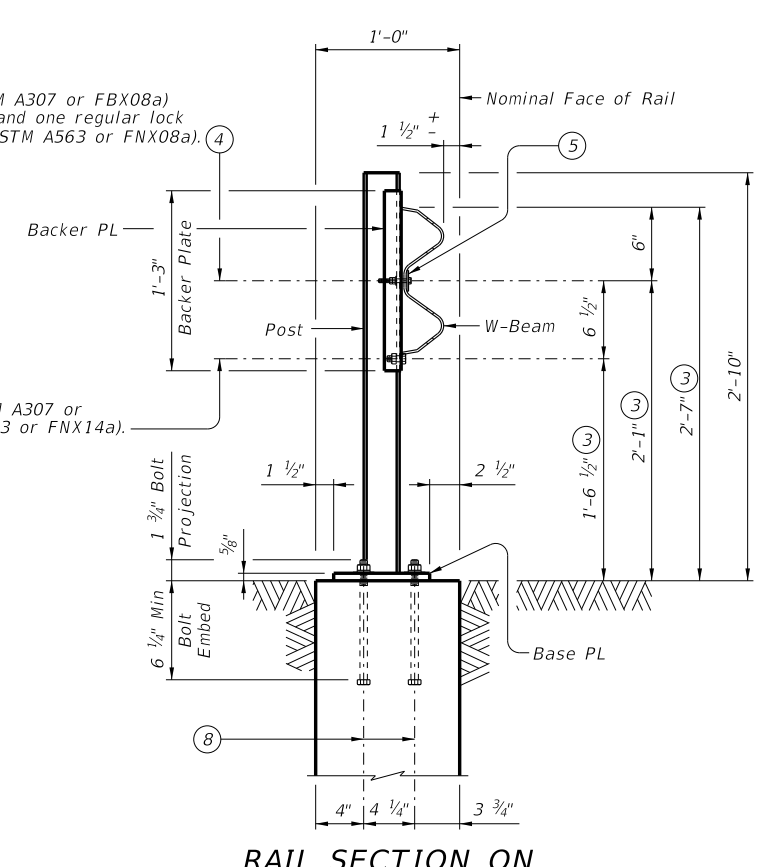

RAIL SECTION ON ABUTMENT WINGWALL

Showing without overlay.

SHEET 1 OF 2

		Bridge Division Standard		
TRAFFIC RAIL				
TYPE T631				
FILE: RL-T631-23.dgn	DN: TxDOT	CK: AES	DW: JTR	CK: AES
©TxDOT September 2019	CONT	SECT	JOB	HIGHWAY
REVISIONS				
07/2020: Allowing 9'-4 1/2" or 6'-3" W-Beam sections	DIST	COUNTY	SHEET NO.	
03/2023: MBGF Notes.				

DATE: FILE:

DISCLAIMER: The use of this standard is governed by the "Texas Engineering Practice Act". No warranty of any kind is made by TxDOT for any purpose whatsoever. TxDOT assumes no responsibility for the conversion of this standard to other formats or for incorrect results or damages resulting from its use.

DATE: FILE:

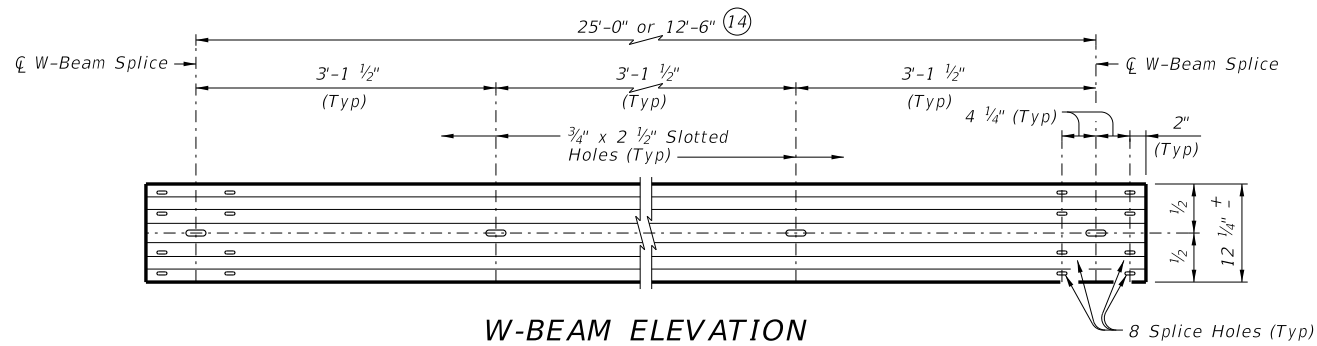

W-BEAM ELEVATION

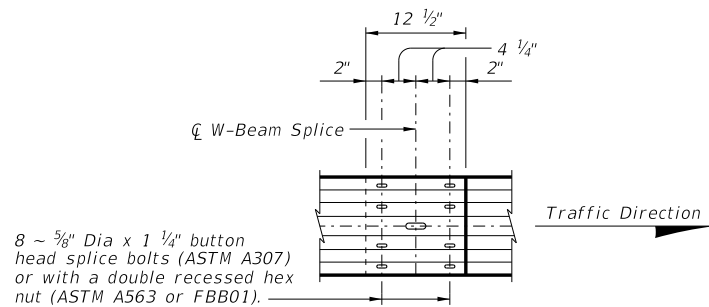

W-BEAM SPLICE ELEVATION

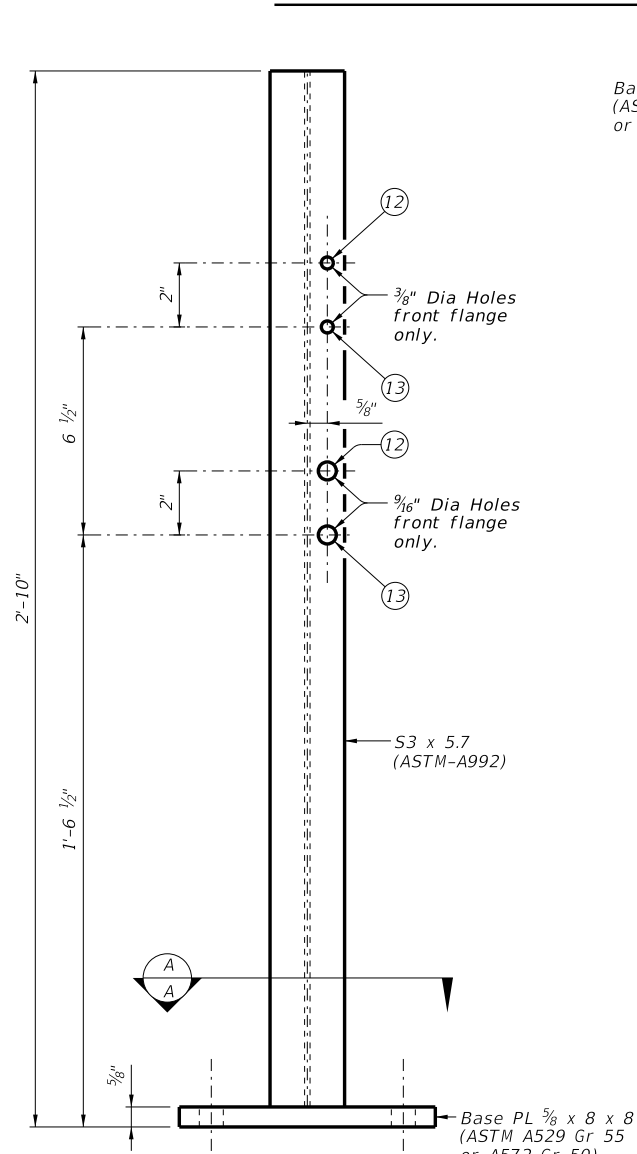

POST ELEVATION

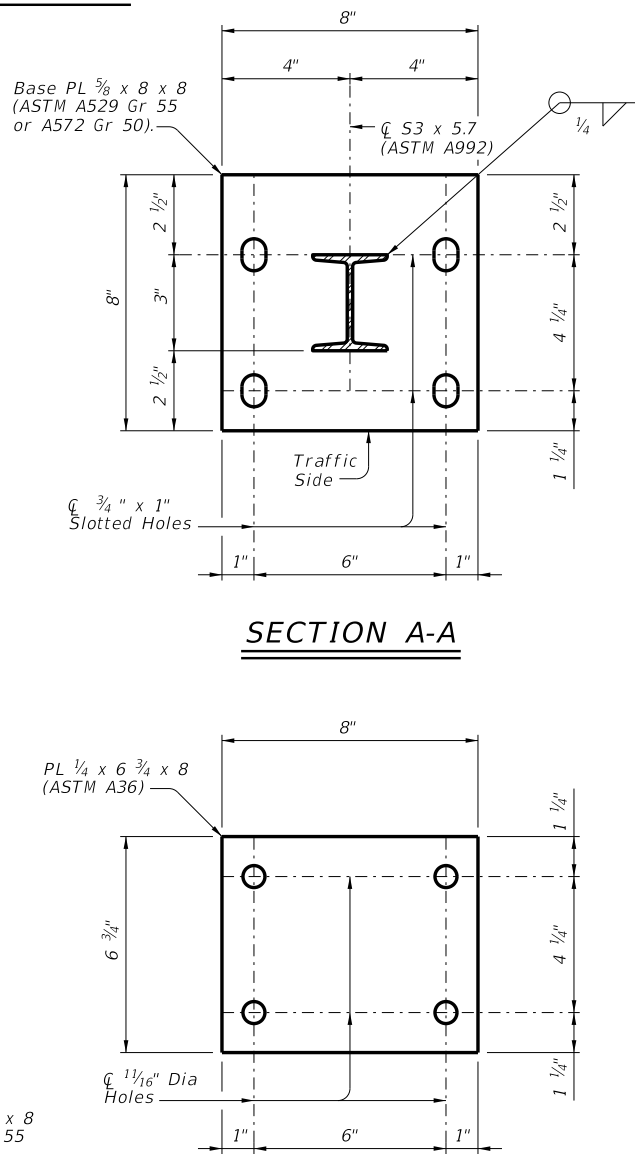

SECTION A-A

WASHER PLATE DETAIL

9/8" Dia heavy hex head anchor bolt (ASTM F3125 Gr A325 or A449) or threaded rod (ATSM A193 Gr B7 or F1554 Gr 105) with one hardened steel washer (ASTM F436) and one regular lock washer placed under heavy hex nut (ASTM A563). One additional heavy hex nut must be furnished and tack welded for each threaded rod.

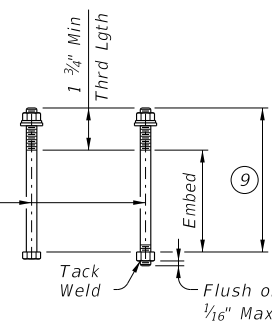

CAST-IN-PLACE & FORMED HOLE ANCHOR BOLT OPTIONS (10)

- (9) See "Rail Details On Bridge Slab" and/or "Rail Section On Abutment Wingwall".
- (10) See "Material Notes" for anchor bolt information.
- (11) Backer PL 1/8" x 8 x 1'-3" (ASTM A1011 CS or SS Gr 33, or A1008 CS or SS Gr 33 (11 Gage acceptable)).
- (12) Used for structures with overlay.
- (13) Used for structures without overlay.
- (14) At the nominal end of the bridge rail for payment, one 9'-4 1/2" or 6'-3" W-beam section is permitted in order to achieve the required W-Beam splice location on the MBGF.

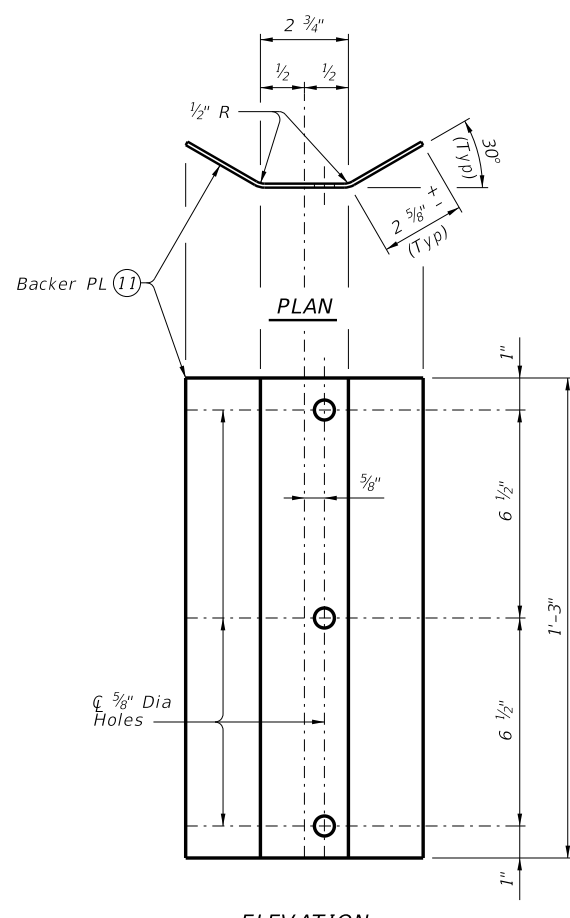

ELEVATION

BACKER PLATE

MBGF AND END TREATMENT NOTES:

This traffic railing must be anchored by metal beam guard fence (MBGF) and guard fence end treatments. Determine MBGF length of need in accordance with the Roadway Design Manual, unless otherwise specified. The minimum MBGF length of need required for anchoring the railing is 25' of MBGF plus the appropriate end treatment installed tangent to the primary roadway.

CONSTRUCTION NOTES:

Face of rail post must be plumb unless otherwise approved by the Engineer. Post must be perpendicular to adjacent roadway grade. Use epoxy mortar under post base plates if gaps larger than 1/16" exist.

Fully anchored guardrail must be attached to each end of rail. A metal beam guard fence transition is not used with this rail.

At the Contractor's option anchor bolts may be an adhesive anchor system. See "Material Notes".

Test adhesive anchors in accordance with Item 450.3.3, "Tests". Test 3 anchors per 100 anchors installed. Perform corrective measures to provide adequate capacity if any of the tests do not meet the required test load. Repair damage from testing as directed.

It is recommended to show a Rail Layout with rail posts and W-beam splices. Fabricator must submit erection drawings to the Engineer for approval.

Round or chamfer exposed edges of rail post and backer plate to approximately 1/16" by grinding.

Shop drawings are not required for this rail.

MATERIAL NOTES:

Galvanize all steel components.

Anchor bolts for base plate must be 3/8" Dia ASTM F3125 Gr A325 or A449 bolts (or ASTM A193 Gr B7 or F1554 Gr 105 threaded rods with one tack welded heavy hex nut each) with one hardened steel washer (ASTM F436) and one regular lock washer placed under each heavy hex nut. Nuts must conform to ASTM A563 requirements.

Optional adhesive anchorage system must be 3/8" Dia ASTM A193 Gr B7 or F1554 Gr 105 fully threaded rods with one hardened steel washer (ASTM F436) and one regular lock washer placed under each heavy hex nut. Nuts must conform to ASTM A563 requirements. Embed fully threaded rod into slab and/or abutment wingwall using a Type III, Class C, D, E, or F anchor adhesive. Minimum adhesive anchor embedment depth is 4 3/4". Anchor adhesive chosen must be able to achieve a nominal bond strength in tension of a single anchor, Na, of 8 kips (edge distance must be accounted for). Submit signed and sealed calculations or the manufacturer's published literature showing the proposed anchor adhesive's ability to develop this load to the Engineer for approval prior to use. Anchor installation, including hole size, drilling, and clean out, must be in accordance with Item 450, "Railing."

W-beam must meet the requirements of Item 540, "Metal Beam Guard Fence" except as modified in the plans. The Contractor may furnish rail elements of 25'-0" or 12'-6" (Nominal) lengths and a single rail element of 9'-4 1/2" or 6'-3" (Nominal) length. W-Beam must have slotted holes at 3'-1 1/2".

Some part numbers from the "Task Force 13" Guide to Standardized Highway Barrier Hardware have been furnished for quick reference.

GENERAL NOTES:

This railing has been successfully evaluated by full-scale crash test to meet MASH TL-3 criteria. This railing can be used for speeds of 50 mph and greater.

This rail is designed to deflect approximately 4' to 4'-6" as it contains and redirects the errant vehicle. This rail may not be installed on top of or behind curbs that project above finished grade, on bridges with expansion joints providing more than 5" movement, on retaining walls, or on grade separations and interchanges.

Repairs to impact-damaged post and base plate unit are not permitted. Replace all impact-damaged posts with a new post and base plate unit.

Average weight of railing with no overlay: 20 plf total.

SHEET 2 OF 2

		Bridge Division Standard	
<h1>TRAFFIC RAIL</h1>			
<h2>TYPE T631</h2>			
FILE: RL-T631-23.dgn	DN: TxDOT	CK: AES	DW: JTR
©TxDOT September 2019	CONT	SECT	JOB
REVISIONS			
07/2020: Allowing 9'-4 1/2" or 6'-3" W-Beam sections	DIST	COUNTY	SHEET NO.
03/2023: MBGF Notes.			