

DISCLAIMER: This standard is governed by the "Texas Engineering Practice Act". No warranty of any kind is made by TxDOT for any purpose whatsoever. TxDOT assumes no responsibility for the conversion of this standard to other formats or for incorrect results or damages resulting from its use.

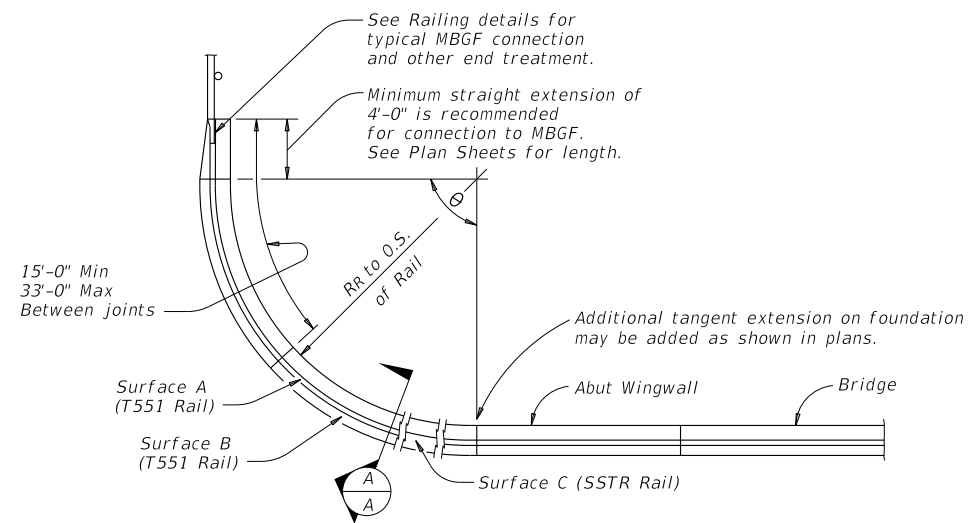

PLAN OF CURVED T551 OR SSTR RAILING AT BRIDGE ENDS

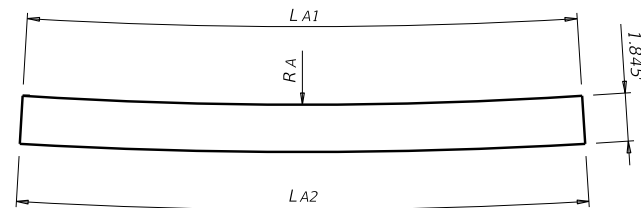

DEVELOPED SURFACE-A
(T551 Rail)

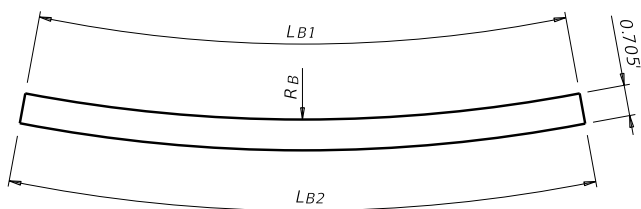

DEVELOPED SURFACE-B
(T551 Rail)

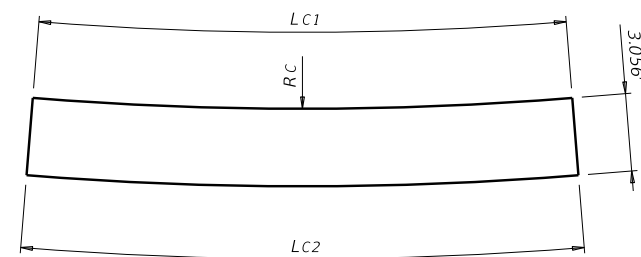

DEVELOPED SURFACE-C
(SSTR Rail)

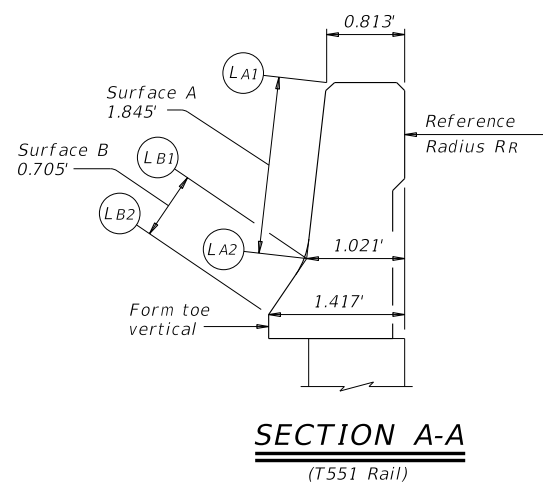

SECTION A-A
(T551 Rail)

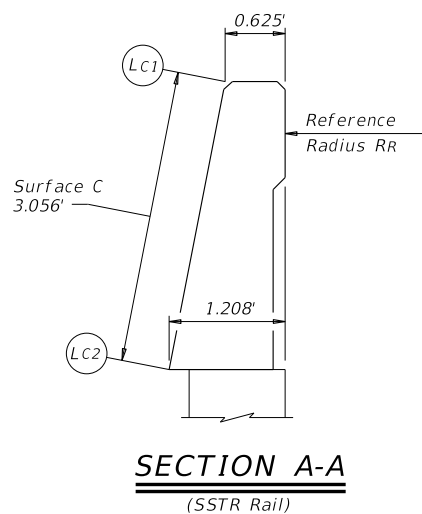

SECTION A-A
(SSTR Rail)

TABLE OF DEVELOPED SURFACES
DIMENSIONS FOR $\theta = 90^\circ$

Reference Radius RR (ft) to back of Rail	T551 RAIL						SSTR RAIL		
	Radius RA ft	Arc Length		Radius RB ft	Arc Length		Radius RC ft	Arc Length	
		LA1 ft	LA2 ft		LB1 ft	LB2 ft		LC1 ft	LC2 ft
10	95.76	16.99	17.31	19.63	17.31	17.93	55.66	16.69	17.61
15	140.04	24.84	25.17	28.54	25.17	25.79	81.86	24.54	25.46
20	184.32	32.69	33.02	37.44	33.02	33.64	108.05	32.40	33.31
25	228.60	40.55	40.87	46.35	40.87	41.50	134.25	40.25	41.17
30	272.88	48.40	48.73	55.25	48.73	49.35	160.44	48.11	49.02

$RA = 8.8560(RR + 0.813')$ $RB = 1.7811(RR + 1.021')$ $RC = 5.2389(RR + 0.625')$
 $LA1 = 1.5708(RR + 0.813')$ $LB1 = 1.5708(RR + 1.021')$ $LC1 = 1.5708(RR + 0.625')$
 $LA2 = 1.5708(RR + 1.021')$ $LB2 = 1.5708(RR + 1.417')$ $LC2 = 1.5708(RR + 1.208')$

The linear ratio may be used to obtain the above arc length dimensions for included θ angles other than 90° . The dimensions are intended as an aid in constructing forms for curved SSTR & Type T551 Railing.

Example: For $RR = 10'$ & $80^\circ \sim LA1 = 16.99(\frac{\theta}{90})$

GENERAL NOTES:

See Railing standards for details not shown.
The primary use of the curved railing detail is to avoid the necessity of curved MBGF at the ends of bridges adjacent to grade intersections.
The associated bridge railing will be paid for by the linear foot which includes the concrete and reinforcement.

DESIGN GUIDANCE:

The use of curved rail sections at bridge ends must be appropriate for the speed and site conditions.



**TRAFFIC RAIL
DEVELOPED SURFACES
FOR T551 & SSTR BRIDGE RAILS**

TRDS

FILE: RL-TRDS-20.dgn	DN: TxDOT	CK: TxDOT	DW: JTR	CK: TxDOT
©TxDOT July 2020	CONT	SECT	JOB	HIGHWAY
REVISIONS	DIST		COUNTY	SHEET NO.

DATE:
FILE: