

DISCLAIMER: The use of this standard is governed by the "Texas Engineering Practice Act". No warranty of any kind is made by TxDOT for any purpose whatsoever. TxDOT assumes no responsibility for the conversion of this standard to other formats or for incorrect results or damages resulting from its use.

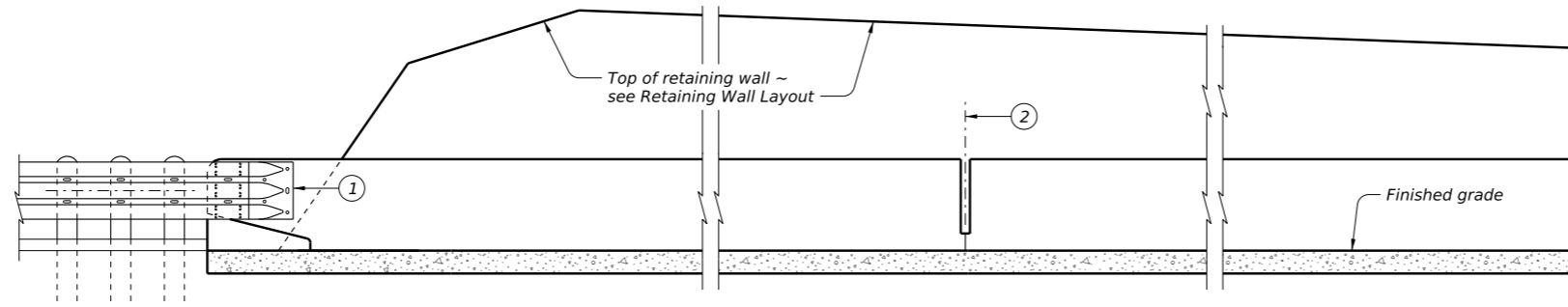

ELEVATION

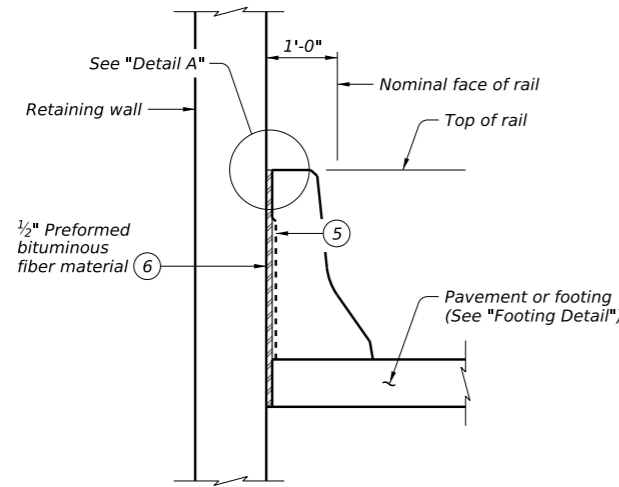

TYPICAL SECTION

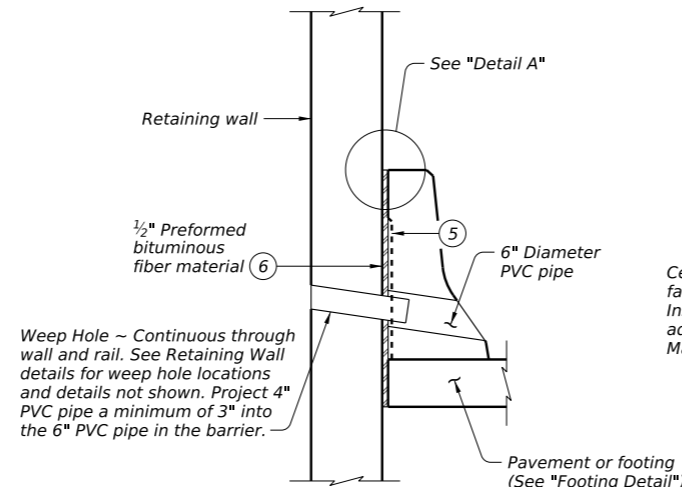

SECTION AT WEEP HOLES

(Do not place weep holes within 1'-4" of intermediate rail joints. Adjust bar spacing or field bend bars in rail as required to clear weep holes by 1" minimum.)

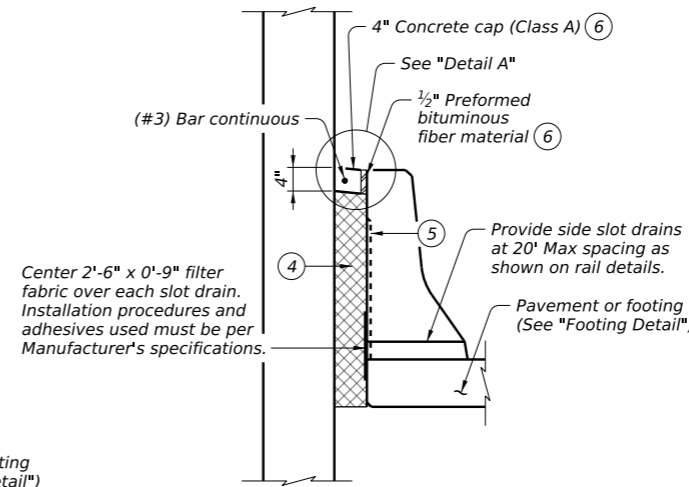

SECTION AT MSE WALLS WITHOUT DRAINAGE SYSTEM

- ① See details elsewhere in plans for rail end treatment.
- ② Provide intermediate rail wall joints at no greater than 100-foot spacing unless shown otherwise on the plans or approved by the Engineer.
- ③ See rail details for anchorage reinforcement. Use anchorage reinforcement required for bridge decks unless noted otherwise.
- ④ Clean gravel (1/4" - 1/2"). Example: Concrete course aggregate grades 6, 7, and 8. The width of the backfill will be dependent upon the width of the coping leg (3 1/2" Min). Minimum backfill width = width of front leg of MSE wall coping.
- ⑤ Do not recess back of rail as shown on rail details.
- ⑥ Place 1/2" bituminous fiber material and concrete cap continuously behind rail expansion joints and rail intermediate wall joints.

SECTIONS A-A

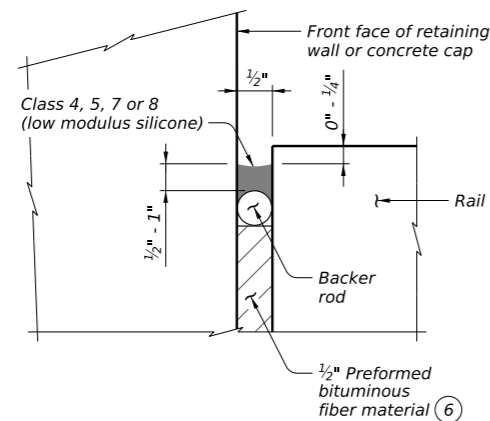

DETAIL A

Place in accordance with Item 438, "Cleaning and Sealing Joints."

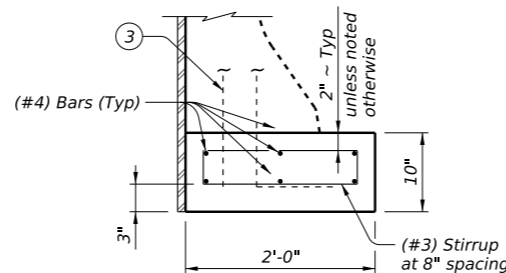

FOOTING DETAIL

Footing for traffic rail required when concrete pavement is not present. This footing is adequate only when back of rail is fully supported by the retaining wall. Use Traffic Railing Foundations (TRF) standard sheet for other cases.

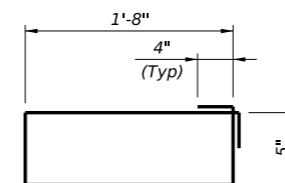

(#3) STIRRUP

MATERIAL NOTES:

Provide Class C concrete (f_c=3,600 psi) for rail footings. Provide Grade 60 reinforcing steel.

GENERAL NOTES:

These details are for constructing a concrete barrier-type rail against a retaining wall. All reinforcing steel, concrete, expansion joint material, etc. shown in these details is subsidiary to the rail type used.

Cover dimensions are clear dimensions, unless noted otherwise. Reinforcing bar dimensions shown are out-to-out of bar.

		Bridge Division Standard	
RETAINING WALL TRAFFIC RAIL AT BASE			
RW(BTR)			
FILE: RW-BTR-25.dgn	DN: TxDOT	CK: TxDOT	DW: TxDOT
© TxDOT October 2025	CONT	SECT	JOB
REVISIONS			
	DIST	COUNTY	SHEET NO.

DATE:
FILE: