

DISCLAIMER: The use of this standard is governed by the "Texas Engineering Practice Act". No warranty of any kind is made by TxDOT for any purpose whatsoever. TxDOT assumes no responsibility for the conversion of this standard to other formats or for incorrect results or damages resulting from its use.

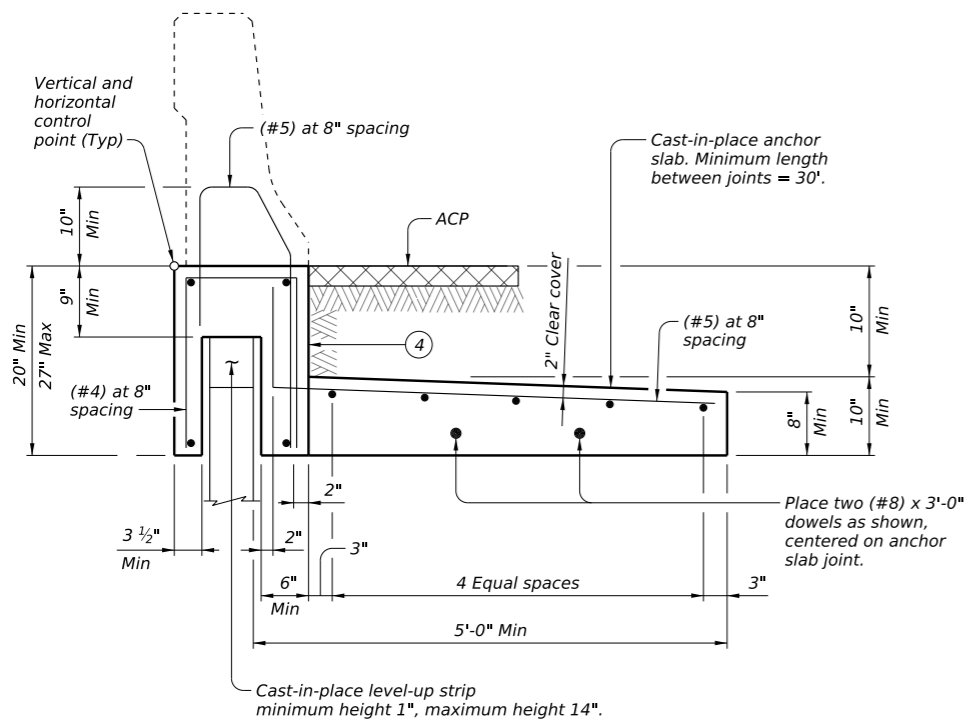

"WIDE BASED" ADJACENT TO ACP

View shows T551 Rail, other rails listed are similar.

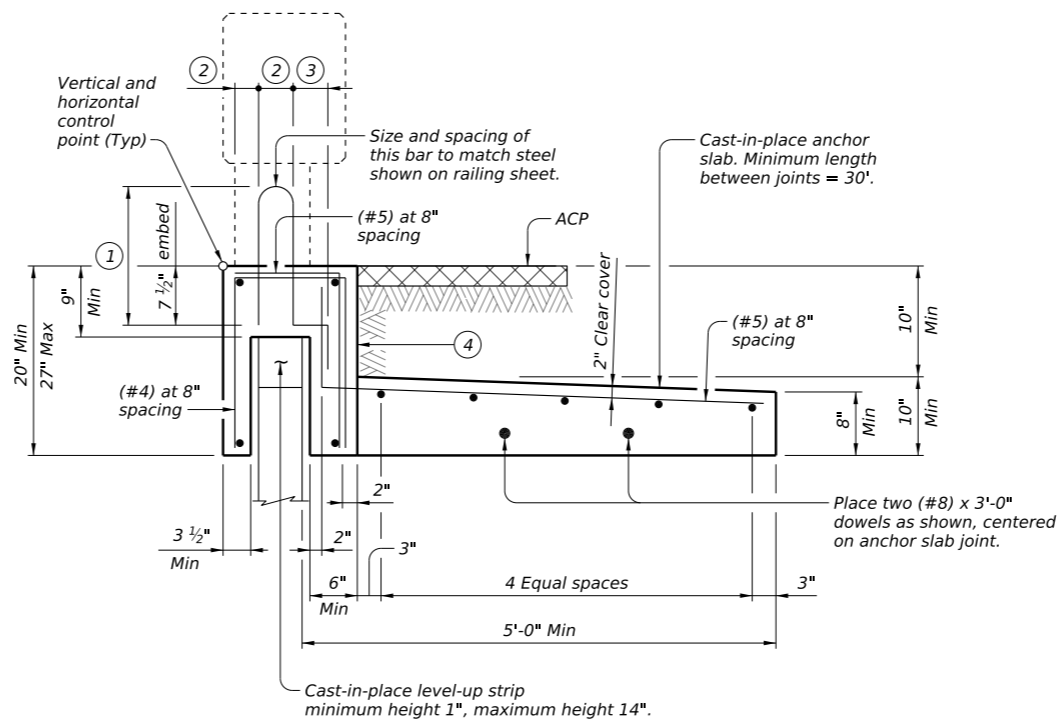

"NARROW BASED" ADJACENT TO ACP

View shows T223 Rail, other rails listed are similar.

- ① Reinforcement length equal to length shown on the appropriate rail standard plus 1 inch.
- ② Match dimension on the appropriate rail standard.
- ③ Match dimension on the appropriate rail standard. Bend end of rail anchorage reinforcing as shown as required to maintain clear cover.
- ④ See "Coping Joint Sealer Details."

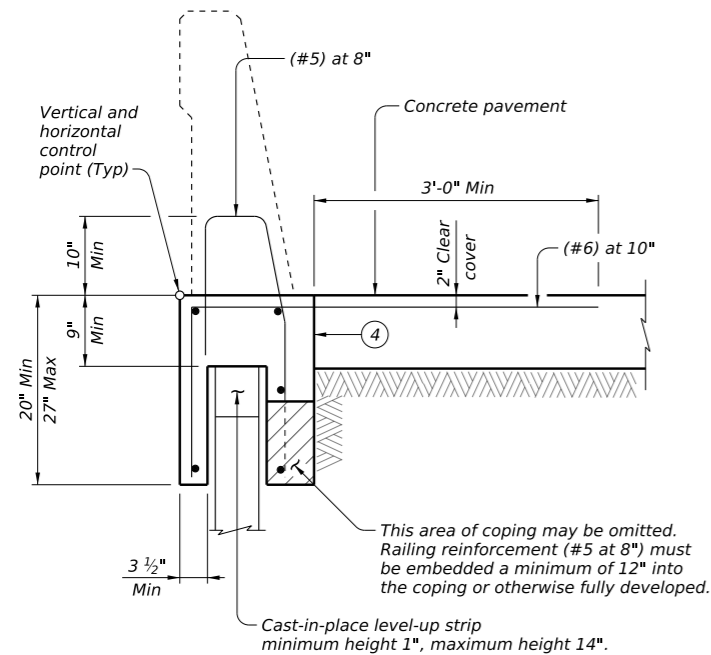

"WIDE BASED" ADJACENT TO CONCRETE PAVEMENT

View shows SSTR Rail, other rails listed are similar.

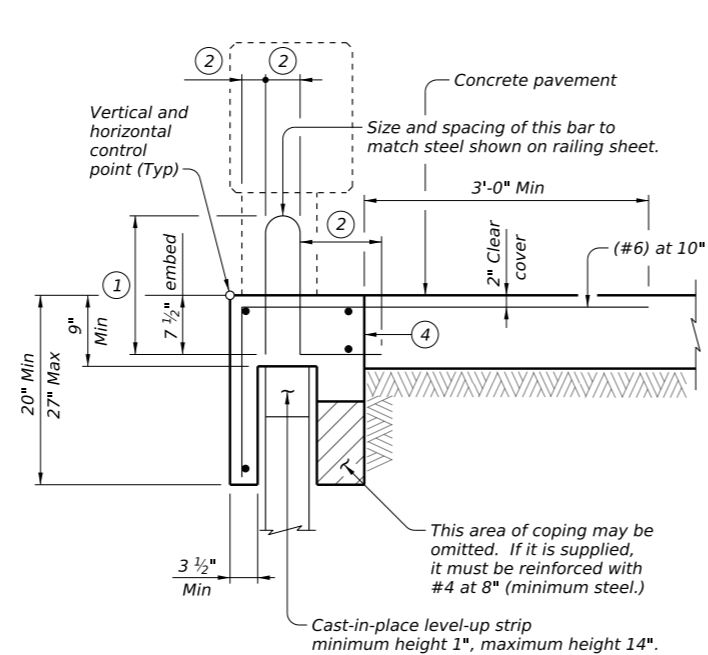

"NARROW BASED" ADJACENT TO CONCRETE PAVEMENT

View shows T223 Rail, other rails listed are similar.

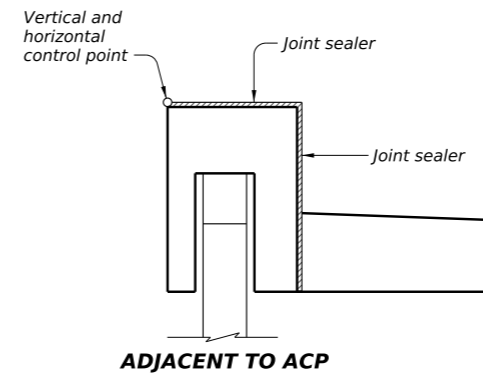

ADJACENT TO ACP

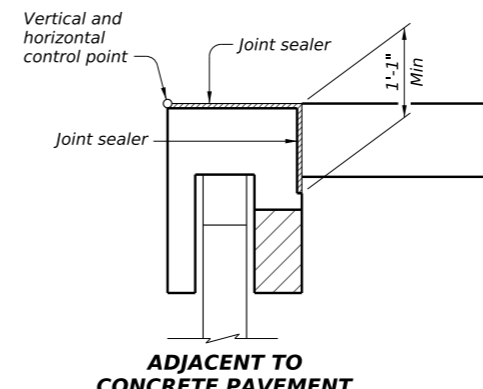

ADJACENT TO CONCRETE PAVEMENT COPING JOINT SEALER DETAILS

Reinforcing steel is not shown for clarity.

Rail Type	Detail	Precasting Rail with Coping Allowed
T1F/T1W/C1W/T2P/C2P	NARROW	NO
T221/C221/T222	NARROW	YES
T223/C223	NARROW	NO
T402/C402	NARROW	NO
T411/C411	NARROW	NO
T551/T552	WIDE	YES
T66	NARROW	NO
SSTR	WIDE	YES

CAST-IN-PLACE COPINGS:

Provide compressible material to isolate precast panel from cast-in-place coping to prevent cracking. Attach compressible material to both sides of precast panel prior to casting concrete for coping.

When cast-in-place coping is anchored to reinforced concrete pavement, provide a smooth level-up strip on the top of the precast panels. The purpose of the level-up is to allow the pavement and coping to move longitudinally relative to the wall without causing damage.

Align coping and railing joints with precast panel joints. Optional rail joints are allowed as approved by Engineer. Provide railing construction joints or expansion joints at 100-foot maximum spacing.

PRECAST COPINGS:

Provide a smooth level-up strip on top of the precast panels prior to installation of the coping. Shims may be used on top of level-up strips to facilitate alignment. Total shim thickness not to exceed 1 inch.

Provide precast coping in 10-foot minimum lengths.

JOINED CONCRETE PAVEMENT:

When coping is adjacent to and anchored into jointed concrete pavement, align the coping joints with the pavement joints.

JOINT SEALANT:

Seal joints between coping segments in accordance with Item 438, "Cleaning and Sealing Joints." Provide Class 4 joint seal. Place sealant flush with coping surface. The purpose of the joint sealing is to reduce surface drainage infiltration into the retaining wall backfill. Sealing coping joint is considered subsidiary to other items.

MATERIAL NOTES:

Provide Class C concrete (f'c=3,600 psi.)
Provide Grade 60 reinforcing steel.
Provide #4 longitudinal bars, unless otherwise shown.

GENERAL NOTES:

Details on this sheet are to be used in development of specific details for mounting traffic railing on mechanically stabilized earth (MSE) walls.

The specific details proposed must have strengths equivalent to those shown on this sheet and must be submitted for approval. Areas of particular importance are the connection of the coping to the railing, the strength of the vertical coping leg connecting the railing to the anchor slab, and the connection of the coping to the anchor slab or concrete pavement.

Submit shop drawings for the traffic railing foundations to the Engineer in accordance with Item 423, "Retaining Walls." The shop drawings must include bar bending details.

Precasting of railing with the coping will be allowed as noted in the table on this sheet.

The Contractor's attention is directed to the fact that various configurations of precast coping/railing combinations are covered by patent. The Contractor must provide for use of these systems in accordance with Article 7.5.

Coping and anchor slabs are considered subsidiary to Item 423, "Retaining Walls." Payment for traffic railing is per the linear foot for the appropriate railing type.

Cover dimensions are clear dimensions, unless noted otherwise.

		Bridge Division Standard	
<h2>RETAINING WALL TRAFFIC RAILING FOUNDATIONS</h2>			
<h3>RW(TRF)</h3>			
FILE: RW-TRF-25.dgn	DN: TxDOT	CK: TxDOT	DW: TxDOT
© TxDOT October 2025	CONT	SECT	JOB
REVISIONS		HIGHWAY	
DIST		COUNTY	
		SHEET NO.	

DATE:
FILE: