

DISCLAIMER: The use of this standard is governed by the "Texas Engineering Practice Act". No warranty of any kind is made by TxDOT for any purpose whatsoever. TxDOT assumes no responsibility for the conversion of this standard to other formats or for incorrect results or damages resulting from its use.

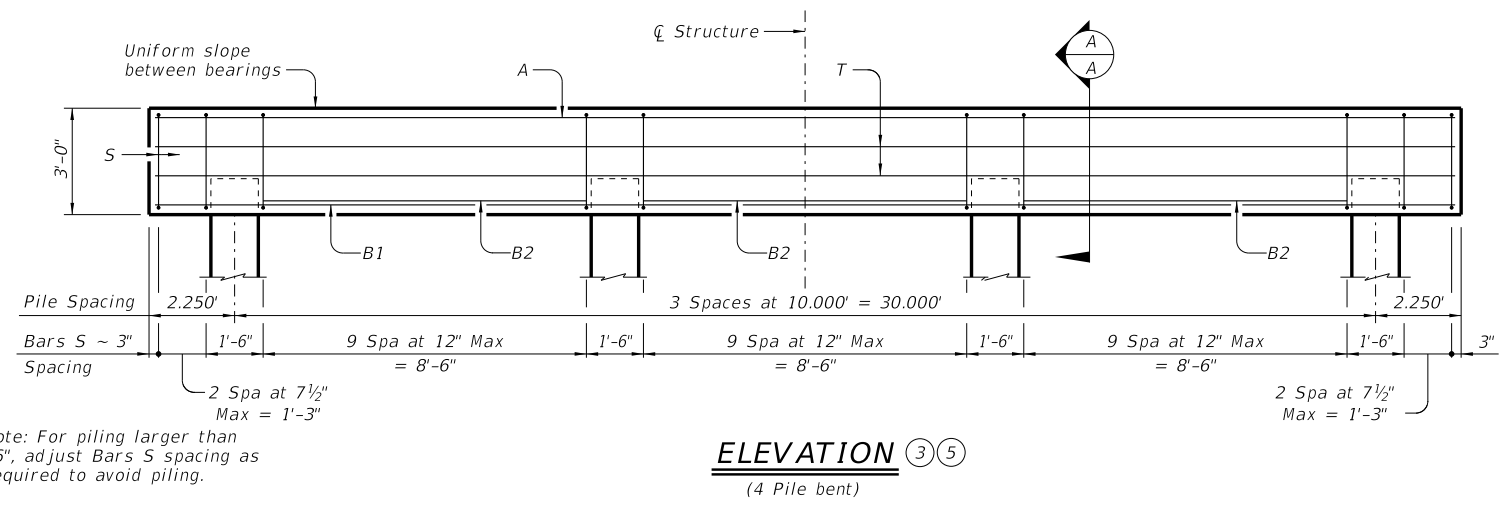

Note: For piling larger than 16", adjust Bars S spacing as required to avoid piling.

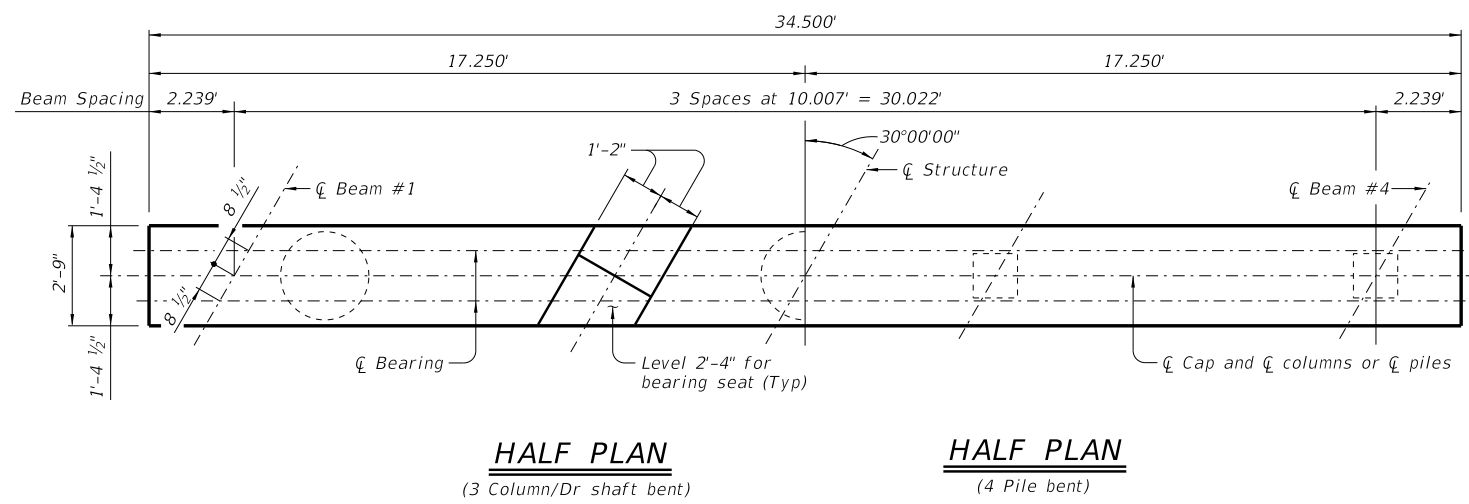
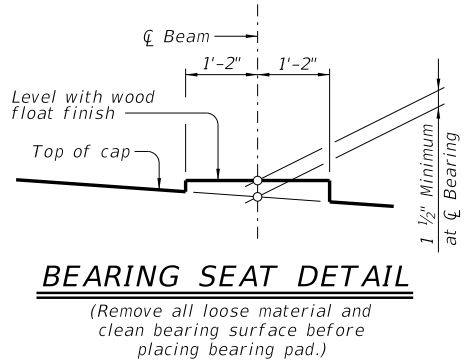
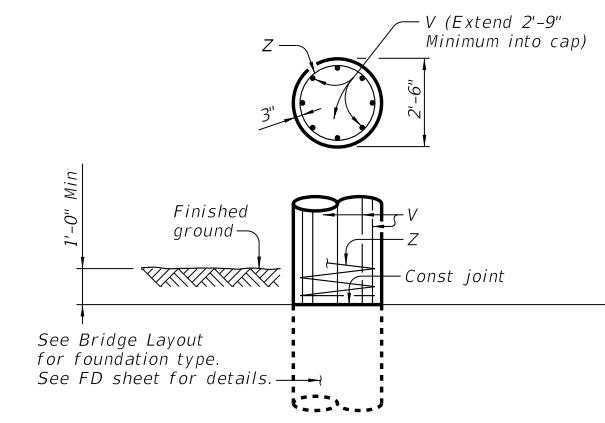
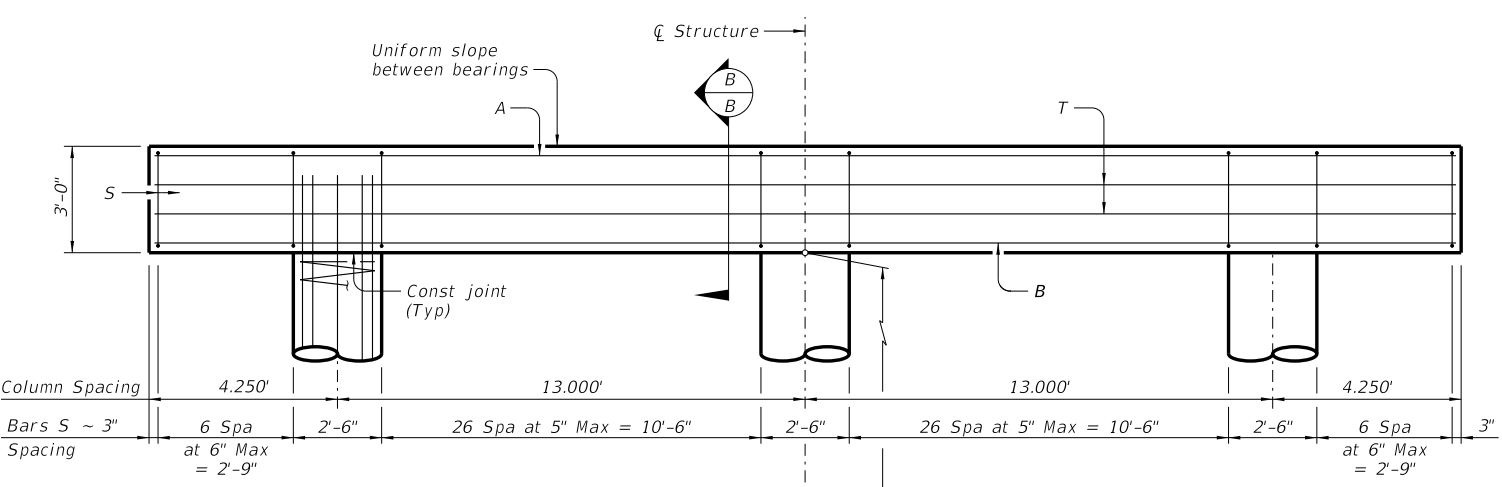

TABLE OF MAXIMUM ALLOWABLE EXPOSED PILE HEIGHTS AND PILE LOADS

Pile Type		Max Ht	Max Load
Concrete	Steel	Ft	Tons/Pile
16" Sq	HP14x73	16	75
18" Sq	HP14x117	20	90
20" Sq	HP18x135	24	110

TABLE OF ESTIMATED QUANTITIES 4 PILE BENT

Bar	No.	Size	Length	Weight
A	5	#9	34'- 2"	581
B1	2	#9	34'- 2"	232
B2	9	#9	8'- 6"	260
S	36	#5	11'- 2"	419
T	4	#5	34'- 2"	143
Reinforcing Steel			Lb	1,635
Class C Concrete (Cap)			CY	10.7

TABLE OF ESTIMATED QUANTITIES FOR 3 COLUMN BENT

Bar	No.	Size	Length	Weight
A	5	#11	34'- 2"	908
B	5	#11	34'- 2"	908
S	68	#5	11'- 2"	792
T	4	#5	34'- 2"	143
V	24	#9	32'- 9"	2,672
Z	3	#3	397'- 0"	448
Reinforcing Steel			Lb	5,871
Class C Concrete (Cap)			CY	10.7
Class C Concrete (Cols)			CY	16.4

TABLE OF FOUNDATION LOADS

Span Length	Shaft Load	Pile Load
Ft	Tons/Shaft	Tons/Pile
30	71	45
35	76	48
40	82	53
45	88	57
50	94	62
55	99	66
60	105	70
65	111	74
70	117	79
75	123	84
80	130	89
85	136	94
90	145	100
95	150	104
100	158	110
105	163	(5)
110	173	(5)
115	180	(5)
120	189	(5)

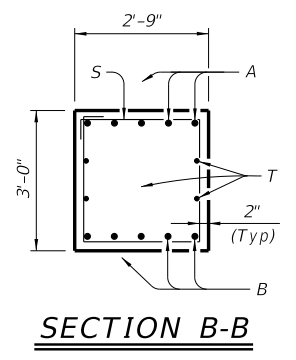
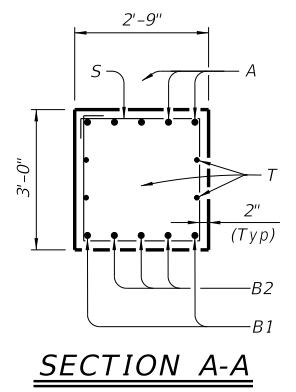

MATERIAL NOTES:

Provide Class C concrete (f'c = 3,600 psi).
 Provide Class C (HPC) concrete if shown elsewhere in the plans.
 Provide Grade 60 reinforcing steel.

GENERAL NOTES:

Designed according to AASHTO LRFD Bridge Design Specifications.
 Bent selected must be based on the average span length rounded up to the next 5 ft increment.
 For pile bents supporting unequal spans, the shorter span cannot be less than 80 percent of the longer span.
 See Bridge Layout for foundation type, size, and length.
 See Common Foundation Details (FD) standard sheet for all foundation details and notes.
 These bent details do not support the use of multi-pile footings as shown on the FD Standard.
 See Standard Erection and Bracing Requirements (SBBR) standard sheet for location and size of anchor bolt required for erection bracing.
 Details are drawn showing right forward skew. See Bridge Layout for actual skew direction.
 These bent details may be used for the beam types and span lengths shown on the standard SSB-28-30 only.

Cover dimensions are clear dimensions, unless noted otherwise.
 Reinforcing bar dimensions shown are out-to-out of bar.

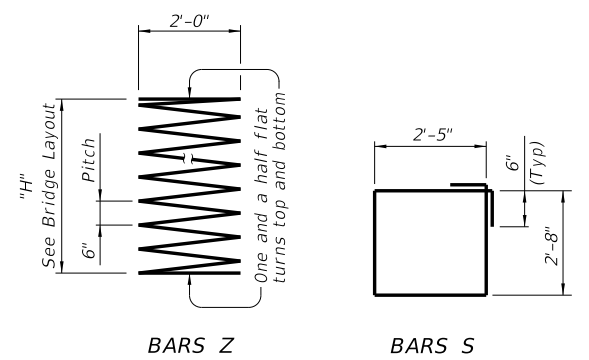

HL93 LOADING

Texas Department of Transportation Bridge Division Standard

INTERIOR BENTS
STEEL BEAM SPANS
28' ROADWAY 30° SKEW

BSB-28-30

FILE: SB-BSB2830-21.dgn	DN: TxDOT	CK: TxDOT	OW: TxDOT	CK: TxDOT
©TxDOT November 2021	CONT	SECT	JOB	HIGHWAY
REVISIONS				
DIST	COUNTY			SHEET NO.

DATE: FILE: