

DISCLAIMER: This standard is governed by the "Texas Engineering Practice Act". No warranty of any kind is made by TxDOT for any purpose whatsoever. TxDOT assumes no responsibility for the conversion of this standard to other formats or for incorrect results or damages resulting from its use.

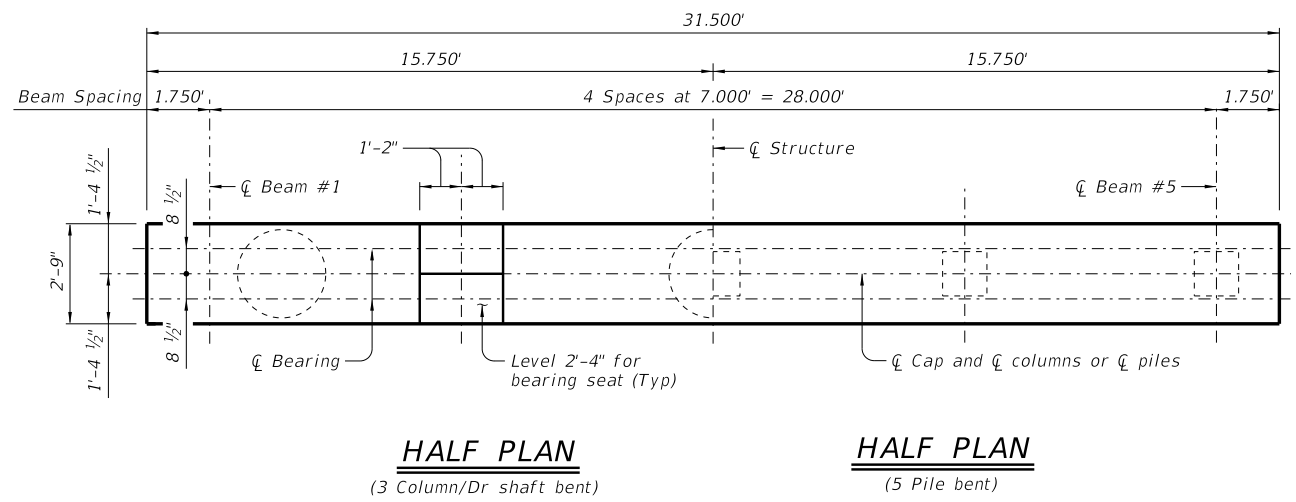

**HALF PLAN**  
(3 Column/Dr shaft bent)

**HALF PLAN**  
(5 Pile bent)

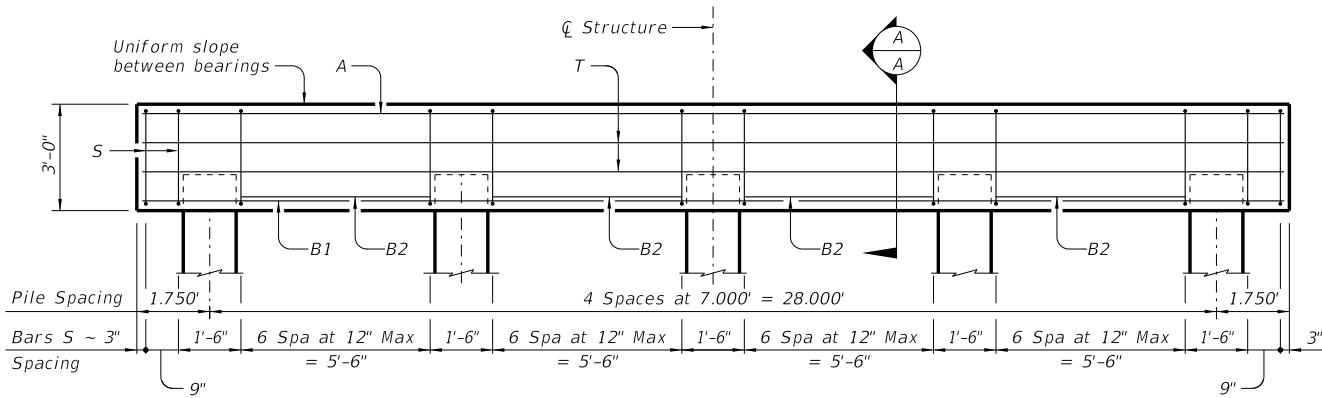

**ELEVATION** (3) (5)  
(5 Pile bent)

Note: For piling larger than 16", adjust Bars S spacing as required to avoid piling.

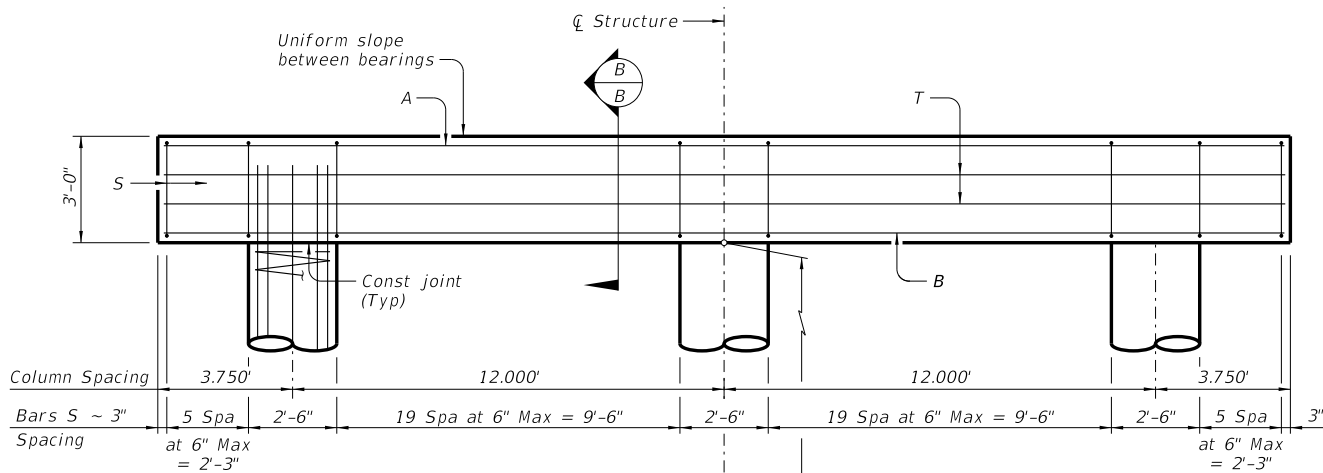

**ELEVATION**  
(3 Column/Dr shaft bent)

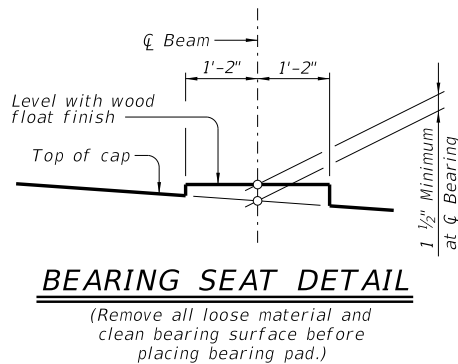
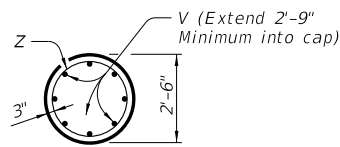

**BEARING SEAT DETAIL**

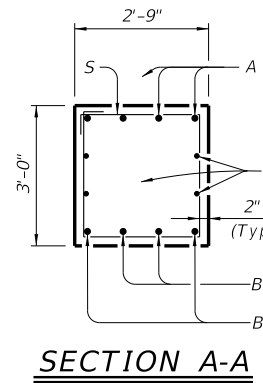

**SECTION A-A**

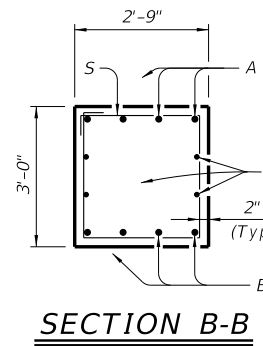

**SECTION B-B**

**TABLE OF MAXIMUM ALLOWABLE EXPOSED PILE HEIGHTS AND PILE LOADS**

Pile Type		Max Ht	Max Load
Concrete	Steel	Ft	Tons/Pile
16" Sq	HP14x73	16	75
18" Sq	HP14x117 (4)	20	90
20" Sq	HP18x135	24	110

**TABLE OF ESTIMATED QUANTITIES 5 PILE BENT**

Bar	No.	Size	Length	Weight
A	4	#9	31'- 2"	424
B1	2	#9	31'- 2"	212
B2	8	#9	5'- 6"	150
S	32	#5	11'- 2"	373
T	4	#5	31'- 2"	130
Reinforcing Steel			Lb	1,289
Class C Concrete (Cap)			CY	9.8

**TABLE OF ESTIMATED QUANTITIES FOR 3 COLUMN BENT**

Bar	No.	Size	Length	Weight
A	4	#11	31'- 2"	662
B	4	#11	31'- 2"	662
S	52	#5	11'- 2"	606
T	4	#5	31'- 2"	130
V	24	#9	32'- 9"	2,672
Z	3	#3	397'- 0"	448
Reinforcing Steel			Lb	5,180
Class C Concrete (Cap)			CY	9.8
Class C Concrete (Cols)			CY	16.4

**TABLE OF FOUNDATION LOADS**

Span Length	Shaft Load	Pile Load
Ft	Tons/Shaft	Tons/Pile
30	71	36
35	78	40
40	84	44
45	90	47
50	96	51
55	102	55
60	108	58
65	114	62
70	120	65
75	126	69
80	133	73
85	140	77
90	148	82
95	155	86
100	164	92
105	170	95
110	179	101
115	188	106
120	197	(5)

- (1) Quantities shown are based on an "H" value of 30'-0". For each linear foot variation in "H" value, make the following adjustments:  
Bars V length ~ 1'-0"  
Bars Z length ~ 12'-7"  
Reinforcing Steel ~ 96 Lbs  
Class C Concrete (Columns) ~ 0.55 CY
- (2) Foundation Loads based on "H"=30'.
- (3) This standard may not be used for "H" heights exceeding 30' or exposed pile heights exceeding the values shown in the table. In areas of very soft soil or where scour is anticipated, maximum allowable "H" heights or exposed pile heights must be evaluated by the Engineer prior to the use of this standard.
- (4) When HP14x117 steel piling is specified in the plans, the Contractor has the option of furnishing either HP14x117 or HP16x101 steel piling.
- (5) Maximum average span length allowed for 5 pile bent is 115'.

**MATERIAL NOTES:**

Provide Class C concrete (f'c = 3,600 psi).  
Provide Class C (HPC) concrete if shown elsewhere in the plans.  
Provide Grade 60 reinforcing steel.

**GENERAL NOTES:**

Designed according to AASHTO LRFD Bridge Design Specifications.  
Bent selected must be based on the average span length rounded up to the next 5 ft increment.  
For pile bents supporting unequal spans, the shorter span cannot be less than 80 percent of the longer span.  
See Bridge Layout for foundation type, size, and length.  
See Common Foundation Details (FD) standard sheet for all foundation details and notes.  
These bent details do not support the use of multi-pile footings as shown on the FD Standard.  
See Standard Erection and Bracing Requirements (SBBR) standard sheet for location and size of anchor bolt required for erection bracing.  
These bent details may be used for the beam types and span lengths shown on the standard SSB-30 only.

Cover dimensions are clear dimensions, unless noted otherwise.  
Reinforcing bar dimensions shown are out-to-out of bar.

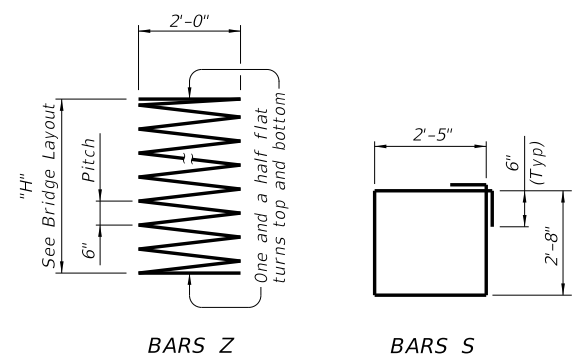

**BARS Z**

**BARS S**

**HL93 LOADING**

Texas Department of Transportation  
Bridge Division Standard

**INTERIOR BENTS  
STEEL BEAM SPANS  
30' ROADWAY**

**BSB-30**

FILE: SB-BSB3000-21.dgn	DN: TxDOT	CK: TxDOT	OW: TxDOT	CK: TxDOT
©TxDOT November 2021	CONT	SECT	JOB	HIGHWAY
REVISIONS				
DIST	COUNTY			SHEET NO.

DATE: FILE: