

DISCLAIMER: This standard is governed by the "Texas Engineering Practice Act". No warranty of any kind is made by TxDOT for any purpose whatsoever. TxDOT assumes no responsibility for the conversion of this standard to other formats or for incorrect results or damages resulting from its use.

DATE: FILE:

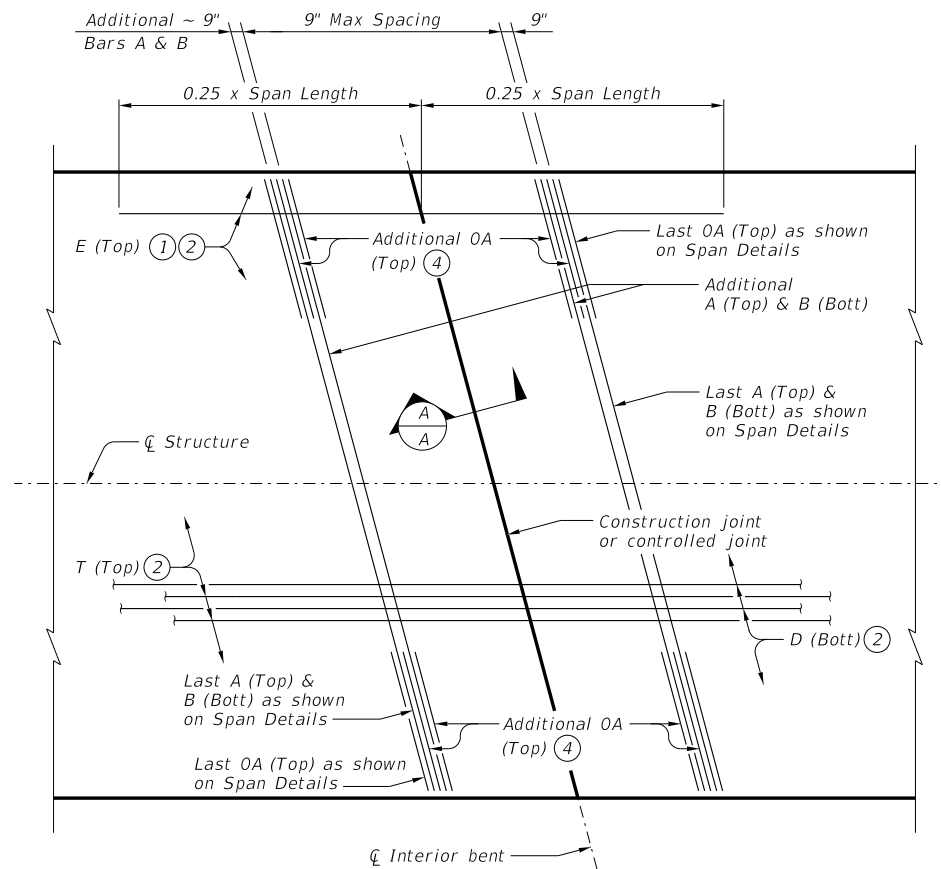

PLAN FOR 0° OR 15° SKEW

(Showing 15° skew.)

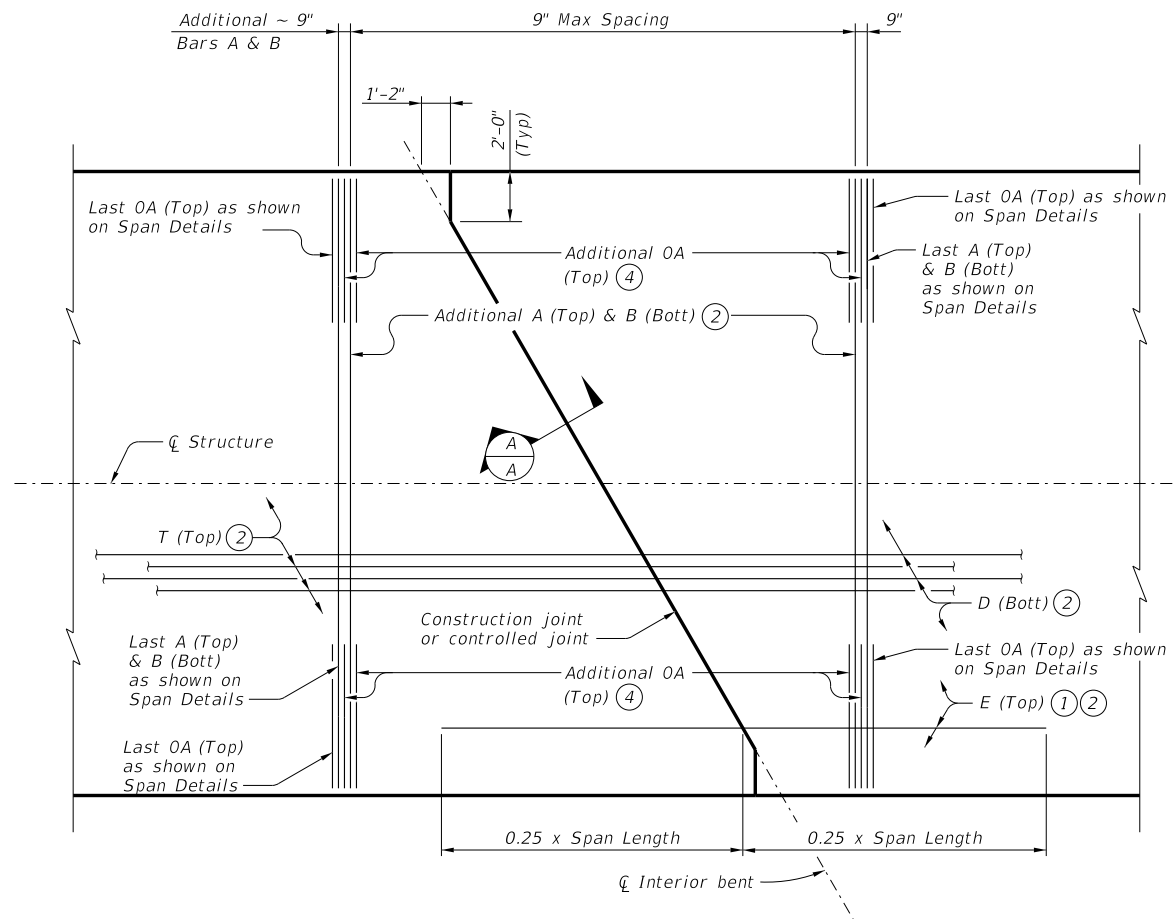

PLAN FOR 30° SKEW

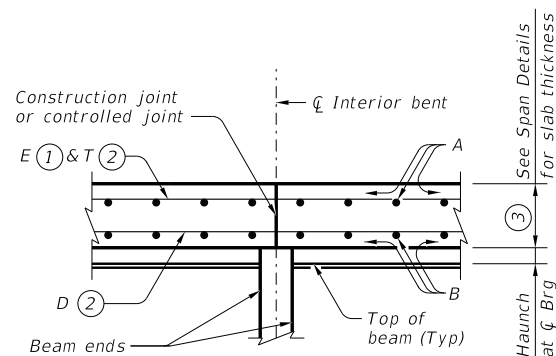

SECTION A-A

(Bars OA (Top) not shown for clarity.)

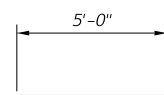

BARS OA #5

The details shown on this sheet are applicable for use only with the Steel Beam Standard Designs shown on standards SBSD-24, SBSD-28 and SBSD-30.

The details shown on this sheet are applicable for two and three span units. Units may be comprised of different span lengths. However, the maximum allowable unit length must not exceed three times the length of the shortest end span for that unit. This limitation is based on the slip resistance of the elastomeric bearings shown on the Elastomeric Bearing Details, Steel Beam Spans (SBEB) standard.

BAR TABLE	
BAR	SIZE
A	#4
B	#4
D	#4
E	#5
T	#4
OA	#5

- ① Place Bars E between Bars T in the top mat of reinforcement over interior bents. Increase reinforcing steel weight by 0.3 lbs/sf of total slab area.
- ② Top and bottom mats must be continuous through joint.
- ③ Maintain a constant slab thickness over the bent.
- ④ Bars OA (Top) at 9" Max spacing between Bars A (Top).

MATERIAL NOTES:
 Provide Grade 60 reinforcing steel.
 Provide Class S concrete (f'c = 4,000 psi).
 Provide Class S (HPC) if shown elsewhere on the plans.
 Provide bar laps, where required, as follows:
 Uncoated ~ #4 = 1'-7"
 Epoxy Coated ~ #4 = 2'-5"

GENERAL NOTES:
 Designed according to AASHTO LRFD Bridge Design Specifications.
 This standard is drawn showing right forward skew. See Bridge Layout for actual skew direction.

CONSTRUCTION NOTES:
 Where multi-span units are indicated on the Bridge Layout, the thickened slab end details and reinforcement shown on Thickened Slab End Details, Steel Beam Spans (SBTS) standard (Bars AA, G, H, J, K, and M) and on the span details will be omitted where slabs are continuous over interior bents. At these locations, the slab details and reinforcement will be as shown on this sheet or on the Prestressed Concrete Panels (PCP) standard (if using this option).
 Thickened slab end reinforcement and details still apply at expansion joint locations (end of units).
 See Span Details for remainder of slab reinforcement and details.

HL93 LOADING



CONTINUOUS SLAB DETAILS STEEL BEAM SPANS

SBCS

FILE: SB-SBCS-21.dgn	DN: TxDOT	CK: TxDOT	DW: TxDOT	CK: TxDOT
©TxDOT November 2021	CONT	SECT	JOB	HIGHWAY
REVISIONS				
DIST	COUNTY		SHEET NO.	