

DISCLAIMER: This drawing is governed by the Texas Engineering Practice Act. No warranty of any kind is made by TxDOT for any purpose whatsoever. TxDOT assumes no responsibility for the conversion of this standard to other formats or for incorrect results or damages resulting from its use.

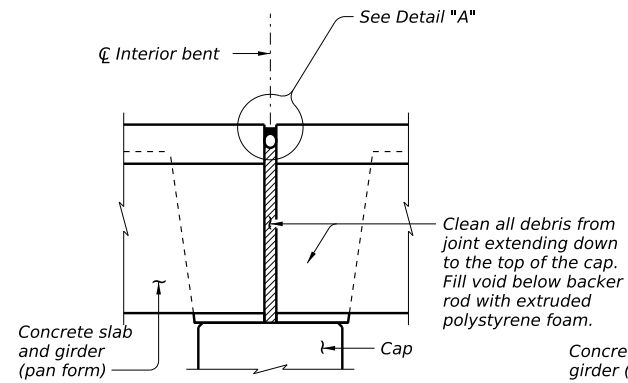

JOINT WITH SILICONE SEAL

(Used without ACP overlay)

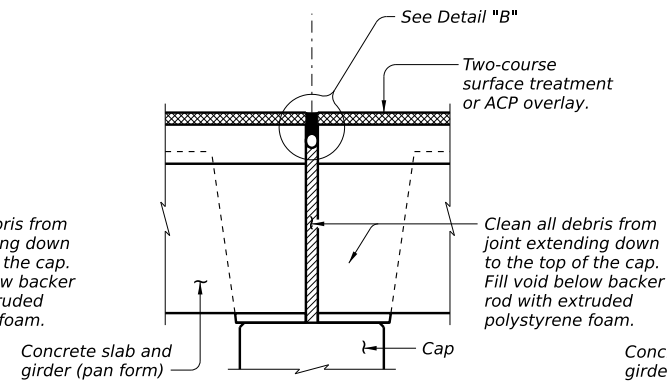

JOINT W/ HOT-POURED RUBBER SEAL

(Used with ACP overlay)

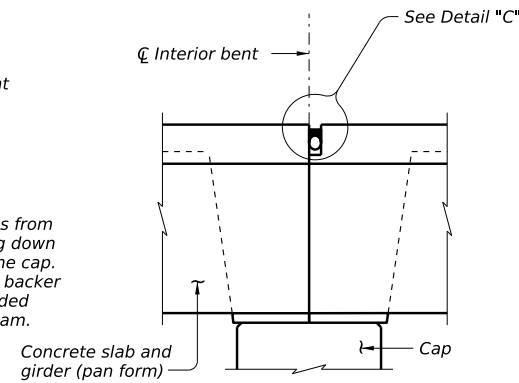

FIXED JOINT

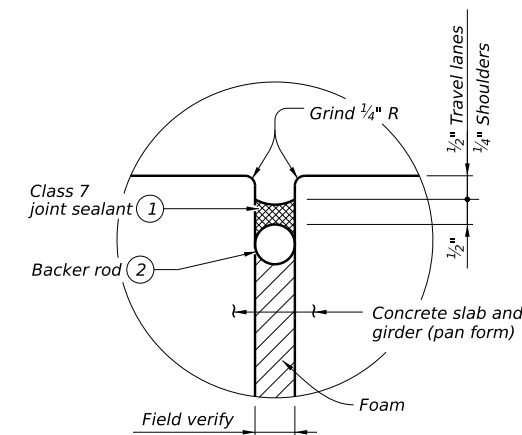

DETAIL "A"

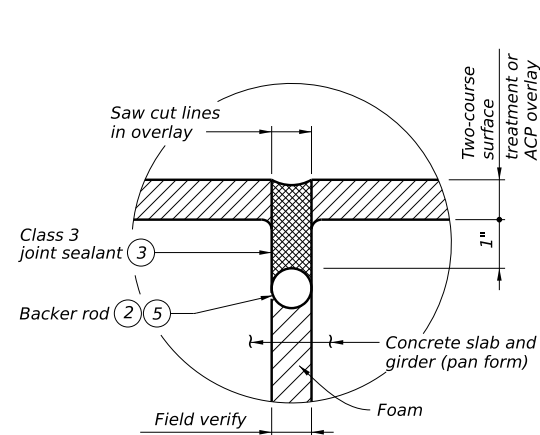

DETAIL "B"

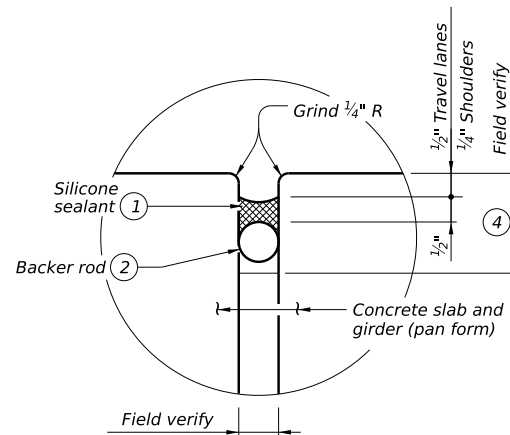

DETAIL "C"

PROCEDURE FOR CLEANING AND SEALING EXISTING CONCRETE GIRDER JOINT WITH SILICONE SEAL:

- 1) Clean joint opening of all existing expansion materials/devices, dirt, and all other deleterious materials in accordance with Item 438, "Cleaning and Sealing Joints." Clean joint out full depth of the joint.
- 2) Obtain approval of cleaned joint prior to proceeding with joint sealing operation.
- 3) Fill void with extruded polystyrene foam.
- 4) Place backer rod into joint opening 1" below the top of concrete.
- 5) Seal the joint opening with a Class 7 joint sealant. Recess seal 1/2" below top of concrete in travel lanes and 1/4" below top of concrete in shoulders.

PROCEDURE FOR CLEANING AND SEALING EXISTING CONCRETE GIRDER JOINT WITH HOT POURED RUBBER SEAL:

- 1) Saw cut through the asphalt at the centerline of joint. Make multiple saw cuts to create a 1/2" minimum joint opening or match the existing joint opening. Clean joint opening of all old expansion materials/devices, bituminous materials, dirt, grease and all other deleterious materials in accordance with Item 438, "Cleaning and Sealing Joints." Clean joint out full depth of the joint.
- 2) Obtain approval of cleaned joint prior to proceeding with joint sealing operation.
- 3) Fill void with extruded polystyrene foam.
- 4) Place backer rod into joint opening 1" below the top of concrete.
- 5) Seal the joint opening with a Class 3 joint sealant. Seal flush to the top of the asphaltic concrete pavement.

PROCEDURE FOR CLEANING AND SEALING EXISTING FIXED JOINTS:

- 1) Remove existing seal and debris from recess.
- 2) Abrasive blast clean existing surfaces where silicone seal is to be placed.
- 3) Obtain approval of cleaned joint prior to proceeding with joint sealing operation.
- 4) Place backer rod into joint opening 1" below the top of concrete.
- 5) Seal the joint opening with a Class 7 joint sealant. Recess seal 1/2" below top of concrete in travel lanes and 1/4" below top of concrete in shoulders.

NOTE TO DESIGNER:
 This drawing shows three options for resealing existing joints on pan girder bridges. For other bridge types and joint sealing options, please see the companion drawing, WD-CSBJ-24.dgn.
 Use Item 438-6002 when specifying Class 3 joint sealant.
 Use Item 438-6004 when specifying Class 7 joint sealant.
 This sheet cannot be used without modification. The details shown may need to be amended if the exact existing conditions are not covered. In all cases, details and notes not required must be deleted. This note and the phrase "Not to be used as a standard" must be removed and the sheet must be signed and sealed by a Professional Engineer.

- 1) Use Class 7 joint sealant. Prepare joint and seal in accordance with Item 438, "Cleaning and Sealing Joints."
- 2) Provide backer rod 25% larger than joint opening and compatible with the sealant. Use of multiple pieces to create a backer rod cross section is not permitted. Top of backer rod must be convex as shown.
- 3) Use Class 3 joint sealant. Prepare joint and seal in accordance with Item 438, "Cleaning and Sealing Joints."
- 4) Backer rod may be omitted if existing joint depth is less than 1 1/2".
- 5) Backer rod must be compatible with the hot poured rubber sealant and rated for a minimum of 400°F.

GENERAL NOTES:

Cleaning existing joint opening (full depth) of all debris, providing and placing backer rod, saw-cutting asphalt overlay, and sealing joint is paid for by Item 438, "Cleaning and Sealing Joints" and measured by the linear foot.
 Obtain approval for all tools, equipment, materials and techniques proposed to clean and seal the joint.
 Provide Class 3 joint sealant in accordance with DMS-6310, "Joint Sealants and Fillers" for joints in asphalt overlay.
 Provide Class 7 joint sealant in accordance with DMS-6310, "Joint Sealants and Fillers" for joints in concrete.
 Extend sealant up into rail or curb 3 inches on low side or sides of deck. If the Class 7 joint sealant cannot be effectively placed in the vertical position, a Class 4 joint sealant compatible with the Class 7 joint sealant is allowed for the extension of the seal into the curb or rail. Prepare surfaces where sealant is to be placed in accordance with Manufacturer's specifications.

SHEET 1 OF 2

				Bridge Division	
<h2>CLEANING AND SEALING EXISTING BRIDGE JOINTS (PAN GIRDER BRIDGES)</h2> <p>(Not to be used as a standard)</p> <p>NBI: XX-XXX-XXXX-XX-XXX</p>					
FILE: WD-CSBJ(PG)-24.dgn	DN: TxDOT	CK: TxDOT	DW: TxDOT	CK: TxDOT	
©TxDOT February 2024	CONT	SECT	JOB	HIGHWAY	
REVISIONS					
	DIST	COUNTY			SHEET NO.

P.E. SEAL REQUIRED
 PRELIMINARY
 SUBJECT TO REVISION

This document is released for informational purposes under the authority of XXX XXX.
 P.E. XXXXX on XX/XX/XX.
 It is not to be used for regulatory approval, permit, bidding, or construction purposes.

DATE:
FILE:

