

DISCLAIMER: This standard is governed by the Texas Engineering Practice Act. No warranty of any kind is made by TxDOT for any purpose whatsoever. TxDOT assumes no responsibility for the conversion of this standard to other formats or for incorrect results or damages resulting from its use.

DATE: FILE:

BEARING PAD SUMMARY TABLE

NBI	Abut / Bent No.	Bearing Pad Dimensions			Sole Plate Dimensions		H (inch) (H=T+1")	Beam Slope	Bearing Pad Type	Quantity
		L (inch)	W (inch)	T (inch)	L (inch)	W (inch)				

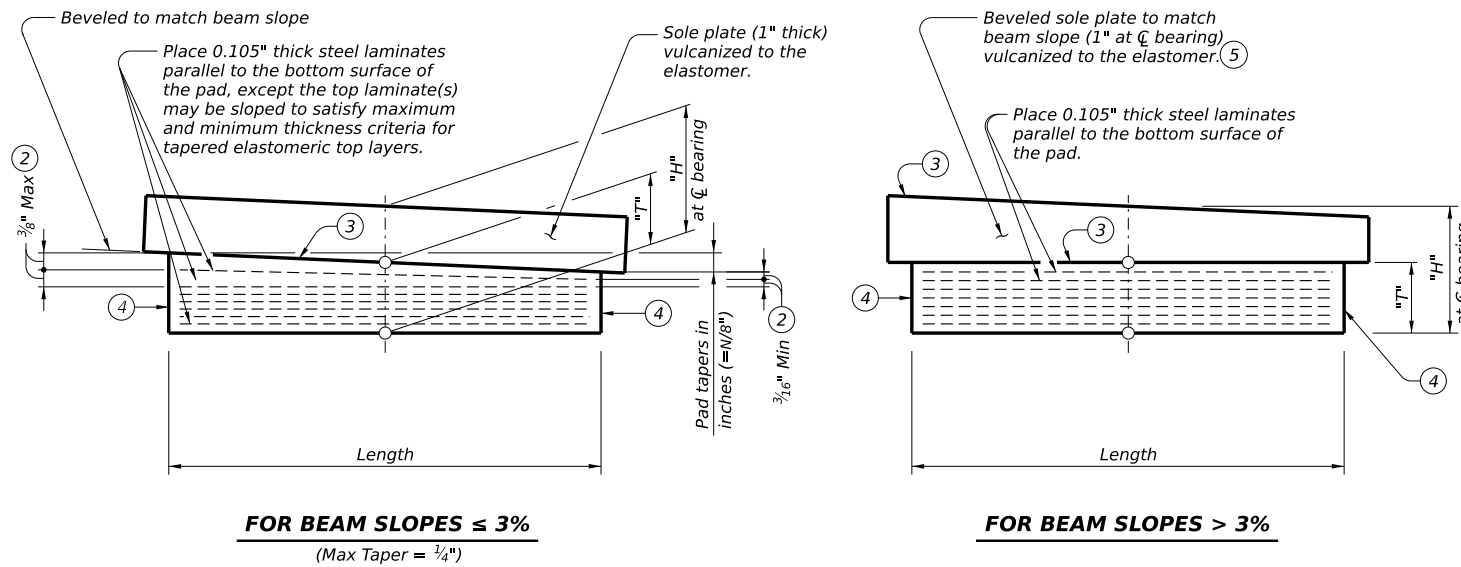

LAMINATED ELASTOMERIC BEARING PAD DETAILS

(50 DUROMETER)

NOTE - Showing standard bearing pad design. Designer to determine layer thicknesses, pad durometer, and number of layers required and modify detail as needed.

- ① 1" Dia threaded rod (ASTM A 193 Gr B7 or F 1554 Gr 105) with heavy hex nut and plate washer. Hot-dip galvanize rod, nut and washer. Sizing, drilling and cleaning rod holes must follow the adhesive manufacturer's directions. Embed using a Type III (Class C, D, E or F) adhesive meeting the requirements of DMS-6100, "Epoxies and Adhesives." Mix and dispense adhesive with the manufacturer's static mixing nozzle/dual cartridge system.
- ② Maximum and minimum layer thicknesses shown are for elastomer only, on tapered layers.
- ③ Indicate BEARING TYPE on all pads. For tapered pads, locate BEARING TYPE on the high side. Include the value of "N" (amount of taper in 1/8" increments) in this mark. Examples: N=0, (for 0" taper)
N=1, (for 1/8" taper)
N=2, (for 1/4" taper)
(etc.)
Fabricated pad top surface slope must not vary from plan beam slope by more than $\frac{0.0625"}{Length}$ IN/IN.
- ④ Locate permanent mark here.
- ⑤ Beveled steel plates for beam slopes > 3%: For shop plans, establish one edge of beveled steel plates to nearest 1/16" based on required thickness at center of bearing and the slope of the fabricated beams. Thickness tolerance variation from the shop plans is plus or minus 1/16", except that the variation from a plane parallel to the theoretical top surface can not exceed 1/16" total.

MATERIAL NOTES:

Provide sole plates conforming to ASTM A588. Provide anchor bolts conforming to ASTM F1554 Grade 105 or ASTM A193 Grade B7. Provide nuts conforming to ASTM A563 Grade DH, heavy hex or A194 Grade 2H, heavy hex. Provide washers conforming to ASTM F436. Hot dip galvanize rod, nut, and washer as per Item 445, "Galvanizing." Sizing, drilling, and cleaning rod holes must follow the epoxy manufacturer's directions. Use a Type III (Class C) epoxy meeting the requirements of DMS-6100, "Epoxies and Adhesives." Mix and dispense adhesive with the manufacturer's static mixing nozzle/dual cartridge system.

GENERAL NOTES:

Raise structure per Item 495, "Raising Existing Structures" to facilitate bearing pad replacement. Costs of furnishing and installing elastomeric bearing pads, sole plates, and anchor rod assembly are paid for in accordance with Item 434, "Bridge Bearings." The bearing fabricator is required to develop a bearing layout which identifies location and orientation of all bearings. A copy of the bearing layout is to be provided to the Engineer. Permanently mark each bearing in accordance with the bearing layout. Provide shop drawings for approval.

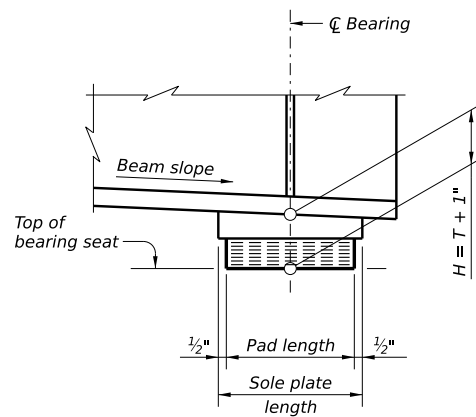

SIDE ELEVATION

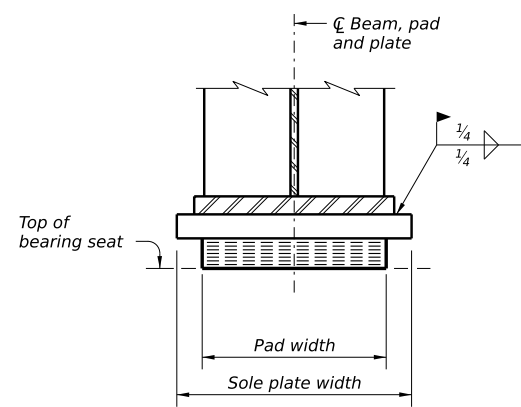

INTERIOR BEAMS

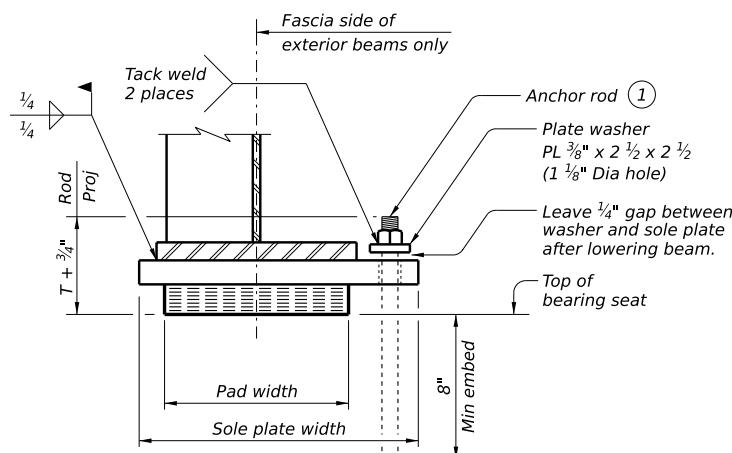

EXTERIOR BEAMS

TRANSVERSE SECTIONS

P.E. SEAL REQUIRED
PRELIMINARY
SUBJECT TO REVISION

This document is released for informational purposes under the authority of XXXX XXXX
P.E. XXXXX on XX/XX/XX.
It is not to be used for regulatory approval, permit, bidding, or construction purposes.

<p>ELASTOMERIC BEARING REPLACEMENT DETAILS FOR STEEL BEAMS</p> <p>(Not to be used as a standard)</p> <p>NBI: XX-XXX-XXXX-XX-XXX</p>			
FILE: WD-EBR(S)-24.dgn	DN: TxDOT	CK: TxDOT	DW: TxDOT
©TxDOT February 2024	CONT	SECT	JOB
REVISIONS	DIST		COUNTY
			SHEET NO.

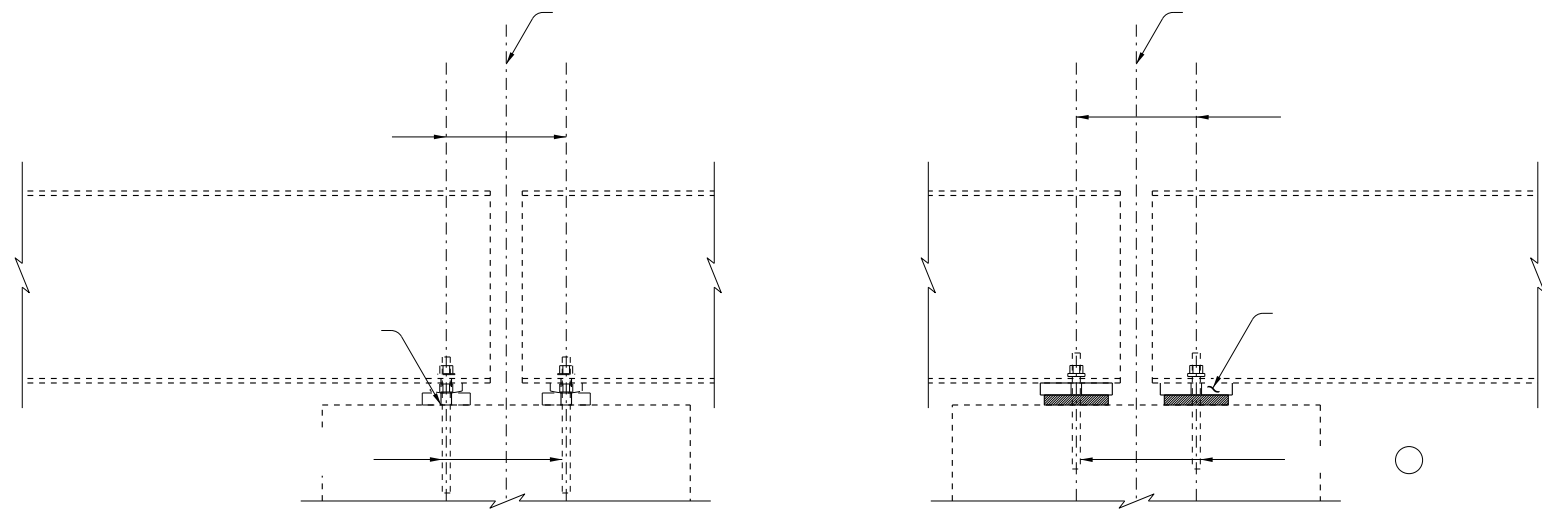

This sheet may not be used without modification. The details shown may need to be amended if the exact existing conditions are not covered. In all cases details and notes not required must be deleted. This note and the phrase "Not to be used as a standard" must be removed and the sheet must be signed and sealed by a Professional Engineer.

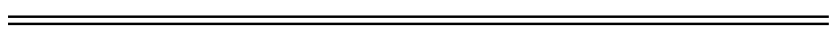
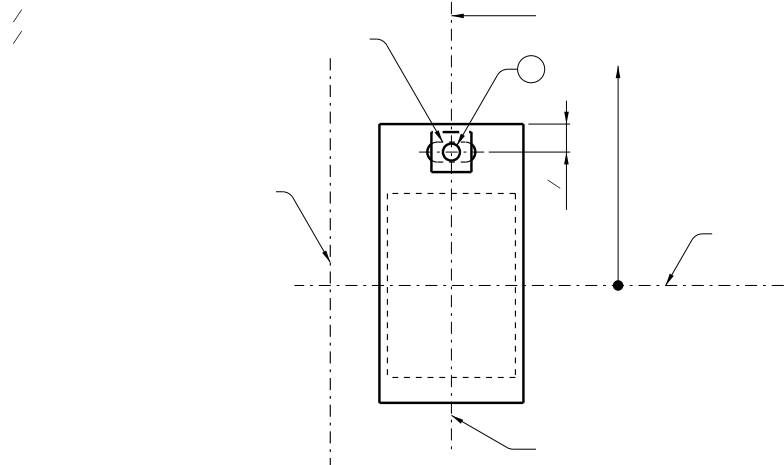

 Texas Department of Transportation		
Empty space for signature and stamp		
<input type="checkbox"/>		