

DISCLAIMER: This standard is governed by the "Texas Engineering Practice Act." No warranty of any kind is made by TxDOT for any purpose whatsoever. TxDOT assumes no responsibility for the conversion of this standard to other formats or for incorrect results or damages resulting from its use.

DATE: FILE:

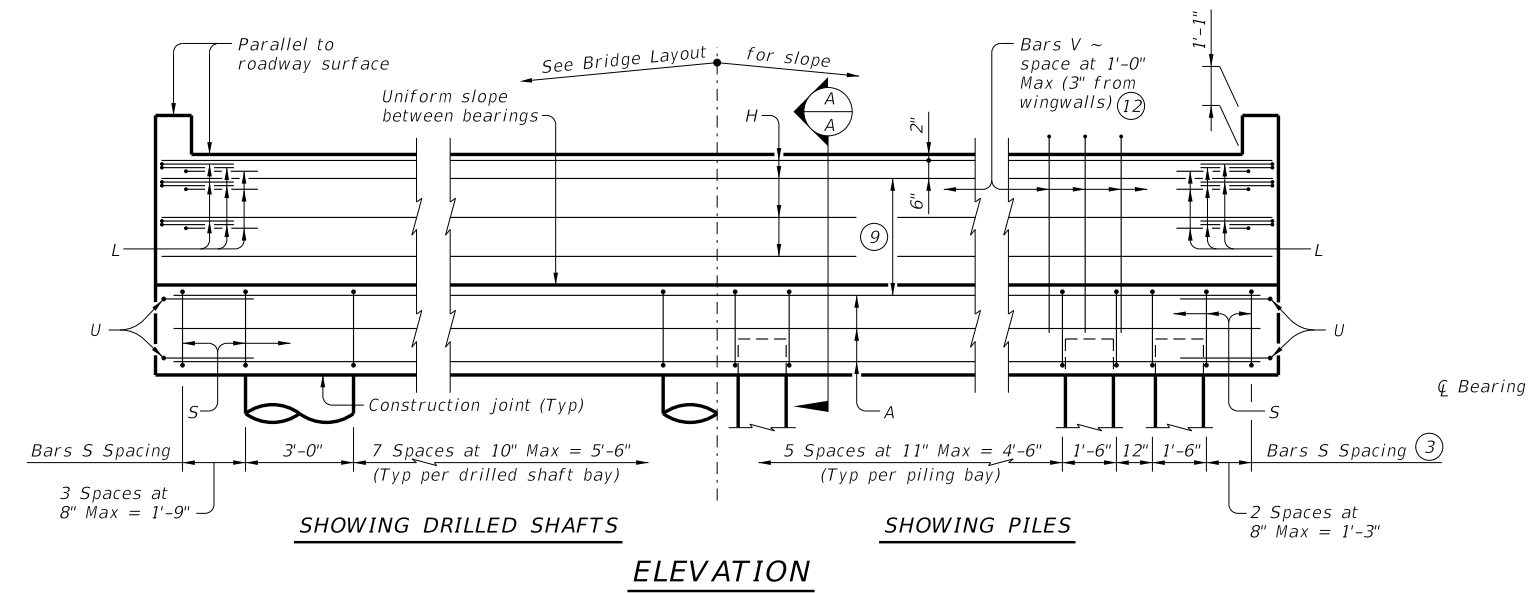

Header Slope	Beam Type	Wingwall Type	Wingwall Length "WL"
2:1	XB20	Cantilevered	7.000'
	XB28	Cantilevered	8.000'
	XB34	Cantilevered	9.000'
	XB40	Cantilevered	10.000'
3:1	XB20	Cantilevered	10.000'
	XB28	Cantilevered	12.000'
	XB34	Founded	13.000'
	XB40	Founded	15.000'

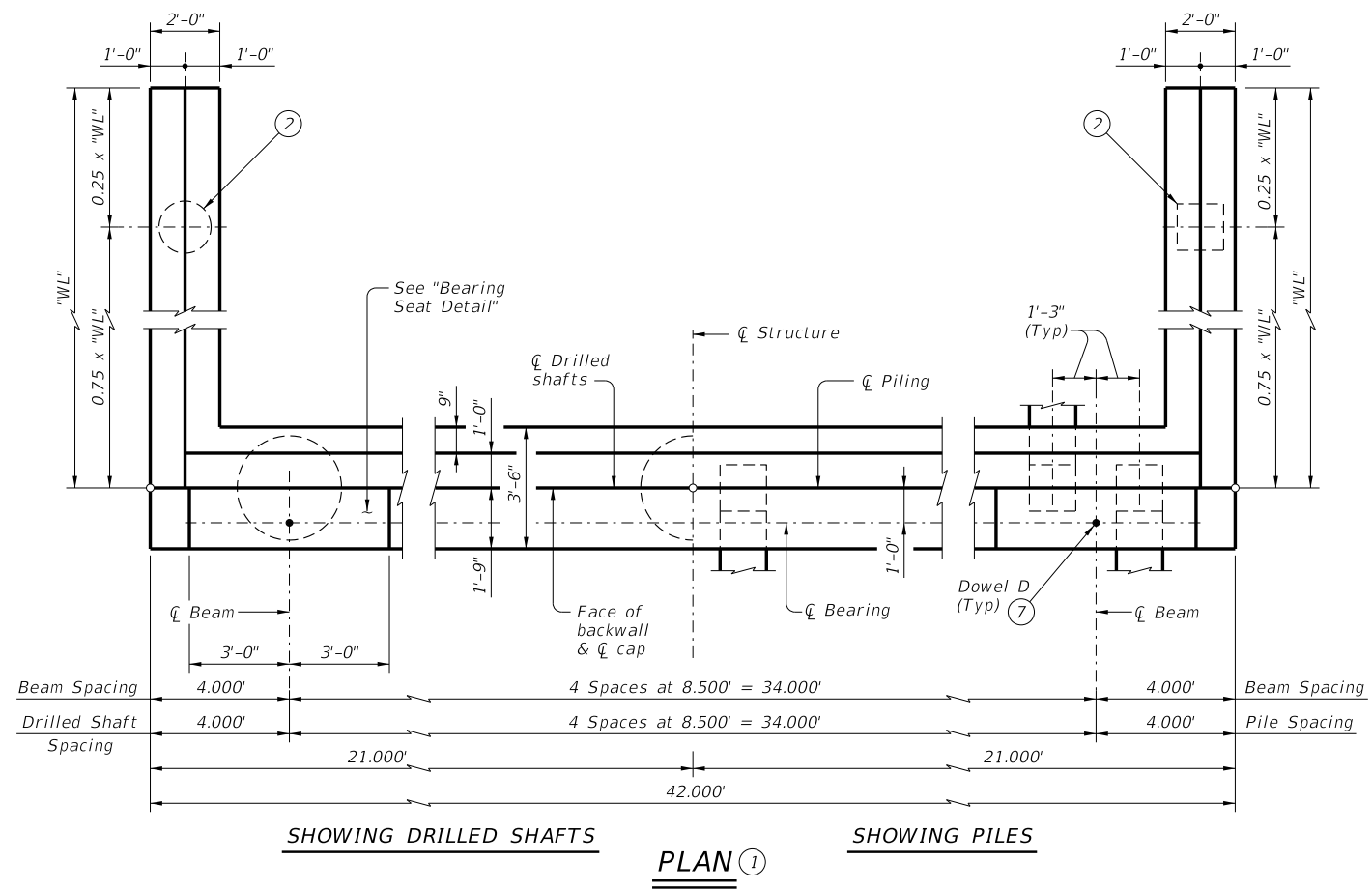
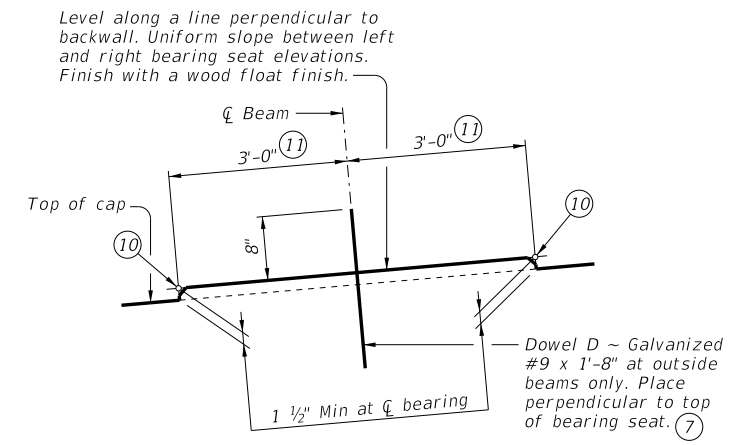
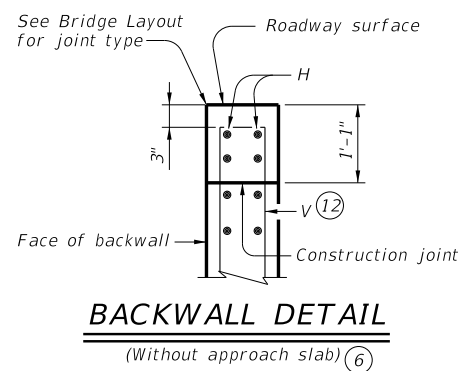

BEARING SEAT DETAIL
(Remove all loose material and clean bearing surface before placing the bearing pad.)

- ① See Table A for variable dimensions based on header slope and beam type.
- ② See Table A to determine if wingwall foundations are required.
- ③ For piling larger than 16" adjust Bars S spacing as required to avoid piling.
- ④ Increase as required to maintain 3" from finished grade.
- ⑤ See Span Details for "Y" value.
- ⑥ See Bridge Layout to determine if approach slab is present.
- ⑦ Omit Dowels D at end of multi-span unit. Adjust reinforcing steel total accordingly.
- ⑧ With pile foundations, move Bars A shown to clear piles.
- ⑨ Spacing based on beam type:
XB20 ~ 2 spaces at 1'-0" Max
XB28 ~ 3 spaces at 1'-0" Max
XB34 ~ 3 spaces at 1'-0" Max
XB40 ~ 3 spaces at 1'-0" Max
- ⑩ Right and left elevations and locations are provided elsewhere.
- ⑪ Measured along \bar{C} of bearing.
- ⑫ Field bend as needed to clear piles.

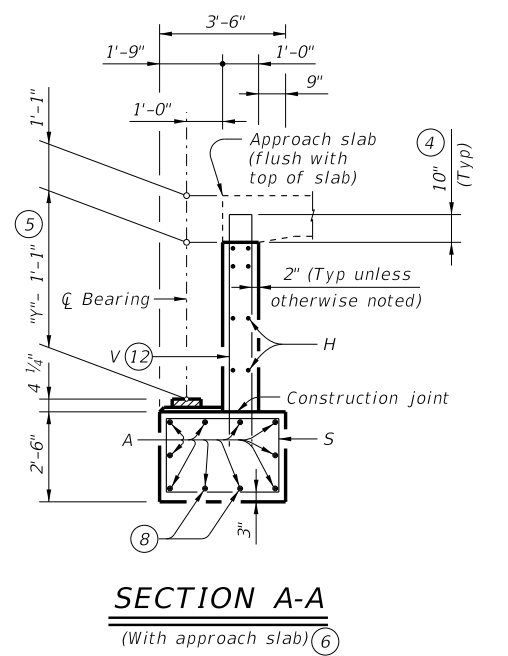

SECTION A-A
(With approach slab) ④

Span Length	Drilled Shaft Load	Battered Pile Load
Ft	Tons/DS	Tons/Pile
40	55	44
45	59	47
50	63	49
55	67	50
60	71	52
65	74	54
70	78	56
75	82	58
80	86	60
85	89	62
90	93	64
95	96	66
100	100	68
105	104	69

MATERIAL NOTES:
Provide Class C concrete ($f'c = 3,600$ psi.)
Provide Class C (HPC) concrete if shown elsewhere in the plans.
Provide Grade 60 reinforcing steel.
Galvanize dowel bars D.

GENERAL NOTES:
Designed according to AASHTO LRFD Bridge Design Specifications.
See Bridge Layout for header slope and foundation type, size and length.
See Common Foundation Details (FD) standard for all foundation details and notes.
See Concrete Riprap (CRR) standard sheet or Stone Riprap (SRR) standard sheet for riprap attachment details, if applicable.
See Shear Key Details (XBSK) standard sheet for all shear key details and notes if applicable.
See applicable rail details for rail anchorage details in wingwalls.
These abutment details may be used with standard SXB-40 only.

Cover dimensions are clear dimensions, unless noted otherwise.
Reinforcing bar dimensions shown are out-to-out of bar.

HL93 LOADING SHEET 1 OF 2

Texas Department of Transportation Bridge Division Standard

ABUTMENTS
PRESTR CONC X-BEAMS
(TYPE 5XB20 THROUGH 5XB40)
40' ROADWAY
AXB-40

FILE: XB-AXB4000-22.dgn	DN: BMP	CK: EFC	DW: JER	CK: BMP
©TxDOT August 2022	CONT	SECT	JOB	HIGHWAY
REVISIONS	DIST	COUNTY	SHEET NO.	

DISCLAIMER: The use of this standard is governed by the "Texas Engineering Practice Act." No warranty of any kind is made by TxDOT for any purpose whatsoever. TxDOT assumes no responsibility for the conversion of this standard to other formats or for incorrect results or damages resulting from its use.

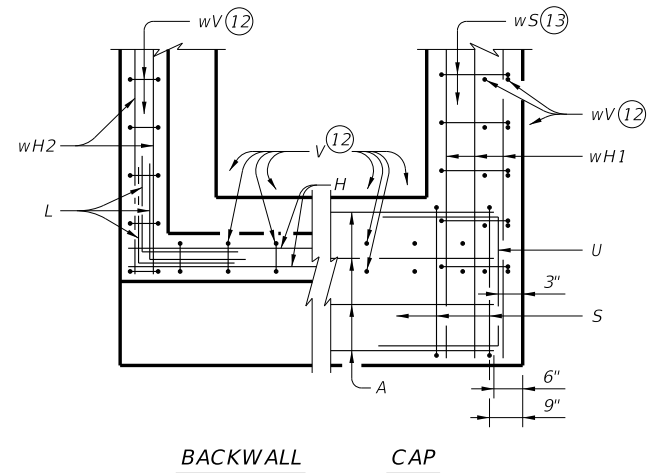

CORNER DETAILS

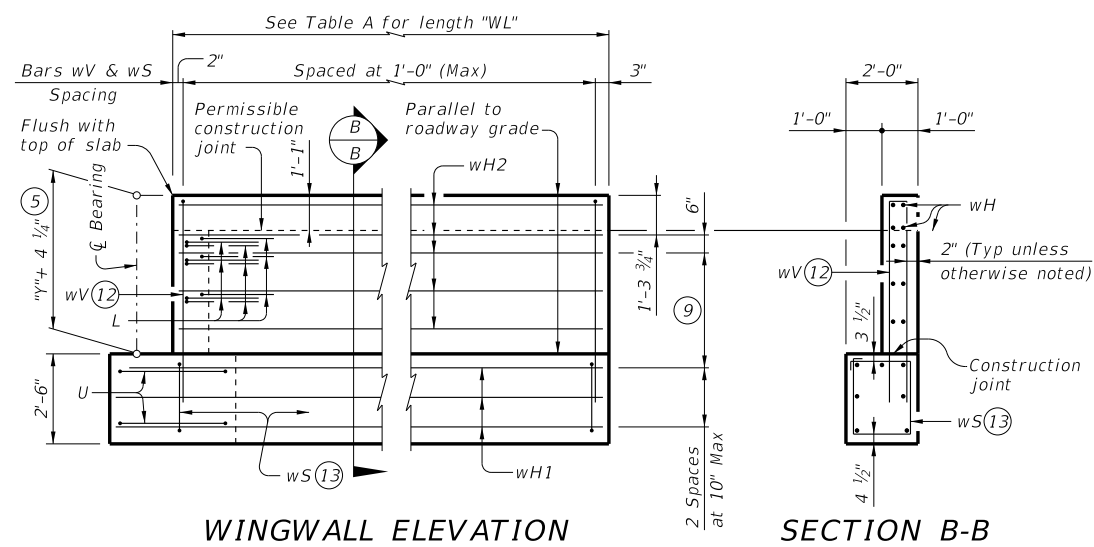

WINGWALL ELEVATION

SECTION B-B

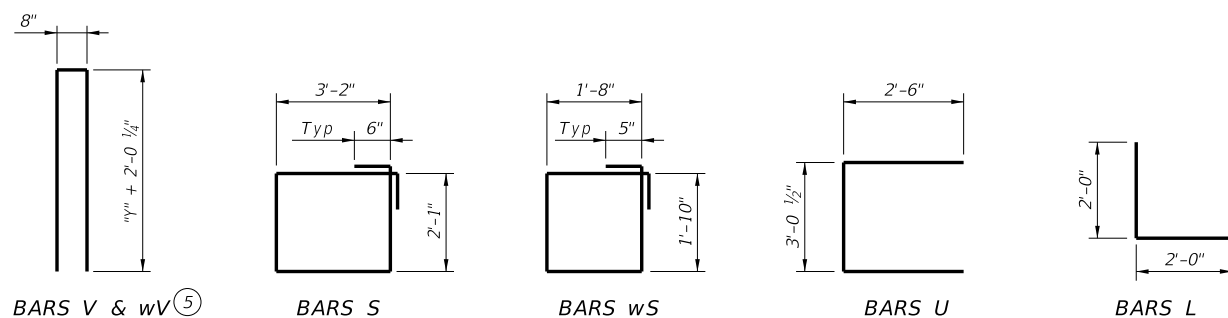

- ⑤ See Span Details for "Y" value.
- ⑦ Omit Dowels D at end of multi-span unit. Adjust reinforcing steel total accordingly.
- ⑨ Spacing based on beam type:
XB20 ~ 2 spaces at 1'-0" Max
XB28 ~ 3 spaces at 1'-0" Max
XB34 ~ 3 spaces at 1'-0" Max
XB40 ~ 3 spaces at 1'-0" Max
- ⑫ Field bend as needed to clear piles.
- ⑬ Adjust as required to avoid piling.
- ⑭ Quantities shown are for one abutment only (with approach slab.) With no approach slab, add 1.6 CY Class C concrete and 250 lbs of reinforcing steel for 4 additional H bars.

TABLES OF ESTIMATED QUANTITIES WITH 2:1 HEADER SLOPE ⑭

TYPE 5XB20 BEAMS					TYPE 5XB28 BEAMS					TYPE 5XB34 BEAMS					TYPE 5XB40 BEAMS								
Bar	No.	Size	Length	Weight	Bar	No.	Size	Length	Weight	Bar	No.	Size	Length	Weight	Bar	No.	Size	Length	Weight				
A	10	#11	41'-0"	2,178	A	10	#11	41'-0"	2,178	A	10	#11	41'-0"	2,178	A	10	#11	41'-0"	2,178				
D(7)	2	#9	1'-8"	11	D(7)	2	#9	1'-8"	11	D(7)	2	#9	1'-8"	11	D(7)	2	#9	1'-8"	11				
H	6	#6	41'-8"	376	H	8	#6	41'-8"	501	H	8	#6	41'-8"	501	H	8	#6	41'-8"	501				
L	18	#6	4'-0"	108	L	18	#6	4'-0"	108	L	18	#6	4'-0"	108	L	18	#6	4'-0"	108				
S	40	#5	11'-6"	480	S	40	#5	11'-6"	480	S	40	#5	11'-6"	480	S	40	#5	11'-6"	480				
U	4	#6	8'-1"	49	U	4	#6	8'-1"	49	U	4	#6	8'-1"	49	U	4	#6	8'-1"	49				
V	41	#5	10'-1"	431	V	41	#5	11'-5"	488	V	41	#5	12'-5"	531	V	41	#5	13'-5"	574				
wH1	14	#6	8'-5"	177	wH1	14	#6	9'-5"	198	wH1	14	#6	10'-5"	219	wH1	14	#6	11'-5"	240				
wH2	16	#6	6'-8"	160	wH2	20	#6	7'-8"	230	wH2	20	#6	8'-8"	260	wH2	20	#6	9'-8"	290				
wS	16	#4	7'-10"	84	wS	18	#4	7'-10"	94	wS	20	#4	7'-10"	105	wS	22	#4	7'-10"	115				
wV	16	#5	10'-1"	168	wV	18	#5	11'-5"	214	wV	20	#5	12'-5"	259	wV	22	#5	13'-5"	308				
Reinforcing Steel				Lb	4,222	Reinforcing Steel				Lb	4,551	Reinforcing Steel				Lb	4,701	Reinforcing Steel				Lb	4,854
Class "C" Concrete				CY	20.2	Class "C" Concrete				CY	22.3	Class "C" Concrete				CY	24.0	Class "C" Concrete				CY	25.7

TABLES OF ESTIMATED QUANTITIES WITH 3:1 HEADER SLOPE ⑭

TYPE 5XB20 BEAMS					TYPE 5XB28 BEAMS					TYPE 5XB34 BEAMS					TYPE 5XB40 BEAMS								
Bar	No.	Size	Length	Weight	Bar	No.	Size	Length	Weight	Bar	No.	Size	Length	Weight	Bar	No.	Size	Length	Weight				
A	10	#11	41'-0"	2,178	A	10	#11	41'-0"	2,178	A	10	#11	41'-0"	2,178	A	10	#11	41'-0"	2,178				
D(7)	2	#9	1'-8"	11	D(7)	2	#9	1'-8"	11	D(7)	2	#9	1'-8"	11	D(7)	2	#9	1'-8"	11				
H	6	#6	41'-8"	376	H	8	#6	41'-8"	501	H	8	#6	41'-8"	501	H	8	#6	41'-8"	501				
L	18	#6	4'-0"	108	L	18	#6	4'-0"	108	L	18	#6	4'-0"	108	L	18	#6	4'-0"	108				
S	40	#5	11'-6"	480	S	40	#5	11'-6"	480	S	40	#5	11'-6"	480	S	40	#5	11'-6"	480				
U	4	#6	8'-1"	49	U	4	#6	8'-1"	49	U	4	#6	8'-1"	49	U	4	#6	8'-1"	49				
V	41	#5	10'-1"	431	V	41	#5	11'-5"	488	V	41	#5	12'-5"	531	V	41	#5	13'-5"	574				
wH1	14	#6	11'-5"	240	wH1	14	#6	13'-5"	282	wH1	14	#6	14'-5"	303	wH1	14	#6	16'-5"	345				
wH2	16	#6	9'-8"	232	wH2	20	#6	11'-8"	350	wH2	20	#6	12'-8"	381	wH2	20	#6	14'-8"	441				
wS	22	#4	7'-10"	115	wS	26	#4	7'-10"	136	wS	28	#4	7'-10"	147	wS	32	#4	7'-10"	167				
wV	22	#5	10'-1"	231	wV	26	#5	11'-5"	310	wV	28	#5	12'-5"	363	wV	32	#5	13'-5"	448				
Reinforcing Steel				Lb	4,451	Reinforcing Steel				Lb	4,893	Reinforcing Steel				Lb	5,052	Reinforcing Steel				Lb	5,302
Class "C" Concrete				CY	22.0	Class "C" Concrete				CY	24.8	Class "C" Concrete				CY	26.7	Class "C" Concrete				CY	29.3



**ABUTMENTS
PRESTR CONC X-BEAMS
(TYPE 5XB20 THROUGH 5XB40)
40' ROADWAY
AXB-40**

FILE: XB-AXB4000-22.dgn	DN: BMP	CK: EFC	DW: JER	CK: BMP
©TxDOT August 2022	CONT	SECT	JOB	HIGHWAY
REVISIONS	DIST	COUNTY	SHEET NO.	

DATE:
FILE: