

DISCLAIMER: The use of this standard is governed by the "Texas Engineering Practice Act." No warranty of any kind is made by TxDOT for any purpose whatsoever. TxDOT assumes no responsibility for the conversion of this standard to other formats or for incorrect results or damages resulting from its use.

DATE: FILE:

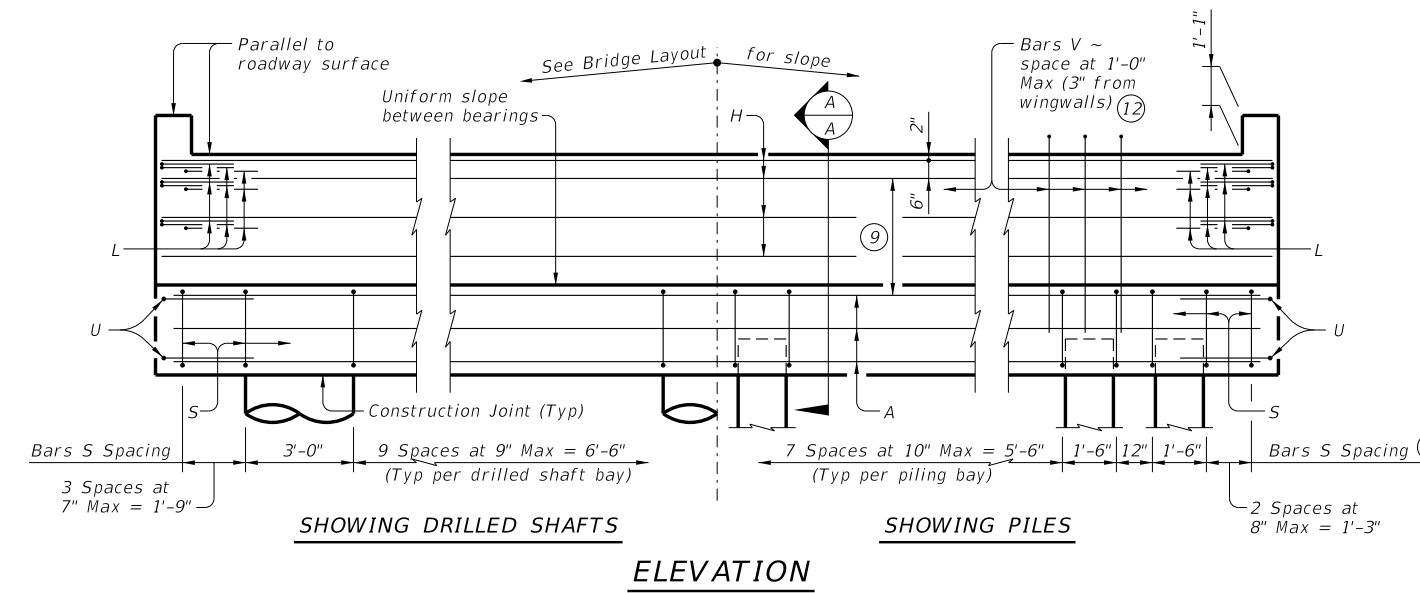

Header Slope	Beam Type	Wingwall Type	Wingwall Length "WL"
2:1	XB20	Cantilevered	7.000'
	XB28	Cantilevered	8.000'
	XB34	Cantilevered	9.000'
	XB40	Cantilevered	10.000'
3:1	XB20	Cantilevered	10.000'
	XB28	Cantilevered	12.000'
	XB34	Founded	13.000'
	XB40	Founded	15.000'

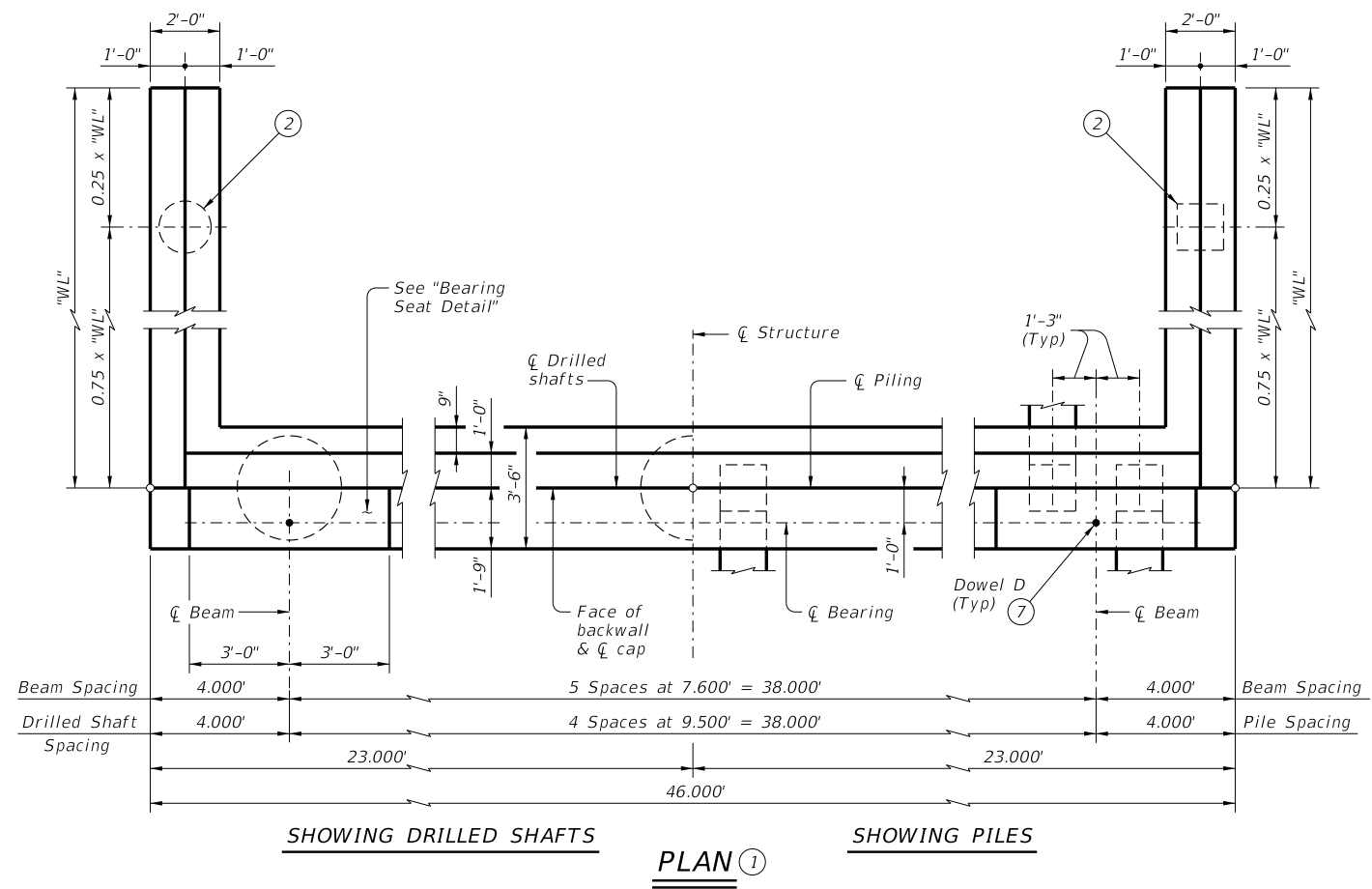
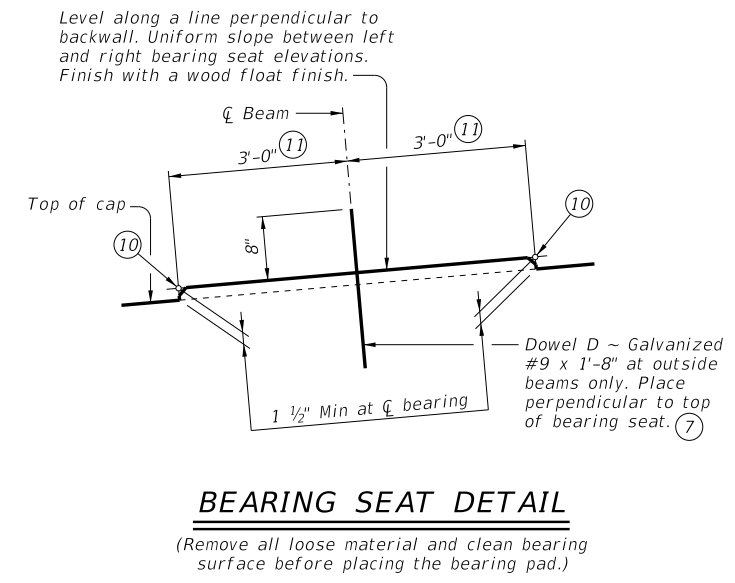
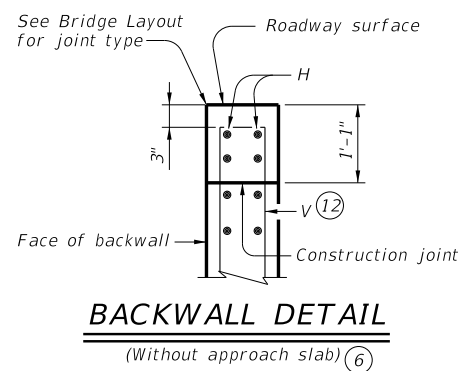

- ① See Table A for variable dimensions based on header slope and beam type.
- ② See Table A to determine if wingwall foundations are required.
- ③ For piling larger than 16" adjust Bars S spacing as required to avoid piling.
- ④ Increase as required to maintain 3" from finished grade.
- ⑤ See Span Details for "Y" value.
- ⑥ See Bridge Layout to determine if approach slab is present.
- ⑦ Omit Dowels D at end of multi-span unit. Adjust reinforcing steel total accordingly.
- ⑧ With pile foundations, move Bars A shown to clear piles.
- ⑨ Spacing based on beam type:
XB20 ~ 2 spaces at 1'-0" Max
XB28 ~ 3 spaces at 1'-0" Max
XB34 ~ 3 spaces at 1'-0" Max
XB40 ~ 3 spaces at 1'-0" Max
- ⑩ Right and left elevations and locations are provided elsewhere.
- ⑪ Measured along \bar{C} of bearing.
- ⑫ Field bend as needed to clear piles.

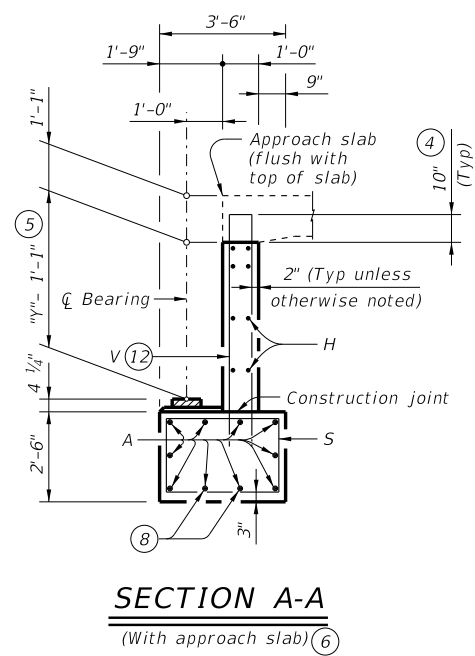

Span Length	Drilled Shaft Load	Battered Pile Load
Ft	Tons/DS	Tons/Pile
40	60	48
45	64	51
50	68	53
55	73	55
60	77	57
65	81	59
70	85	62
75	89	64
80	93	66
85	98	68
90	102	70
95	106	72
100	110	74
105	114	76
110	118	78

MATERIAL NOTES:
 Provide Class C concrete ($f'c = 3,600$ psi.)
 Provide Class C (HPC) concrete if shown elsewhere in the plans.
 Provide Grade 60 reinforcing steel.
 Galvanize dowel bars D.

GENERAL NOTES:
 Designed according to AASHTO LRFD Bridge Design Specifications.
 See Bridge Layout for header slope and foundation type, size and length.
 See Common Foundation Details (FD) standard for all foundation details and notes.
 See Concrete Riprap (CRR) standard sheet or Stone Riprap (SRR) standard sheet for riprap attachment details, if applicable.
 See Shear Key Details (XBSK) standard sheet for all shear key details and notes if applicable.
 See applicable rail details for rail anchorage details in wingwalls.
 These abutment details may be used with standard SXB-44 only.

Cover dimensions are clear dimensions, unless noted otherwise.
 Reinforcing bar dimensions shown are out-to-out of bar.

HL93 LOADING SHEET 1 OF 2

Texas Department of Transportation Bridge Division Standard

ABUTMENTS
PRESTR CONC X-BEAMS
 (TYPE 5XB20 THROUGH 5XB40)
 44' ROADWAY
AXB-44

FILE: XB-AXB4400-22.dgn	DN: BMP	CK: EFC	DW: JER	CK: BMP
©TxDOT August 2022	CONT	SECT	JOB	HIGHWAY
REVISIONS	DIST	COUNTY	SHEET NO.	

DISCLAIMER: The use of this standard is governed by the "Texas Engineering Practice Act." No warranty of any kind is made by TxDOT for any purpose whatsoever. TxDOT assumes no responsibility for the conversion of this standard to other formats or for incorrect results or damages resulting from its use.

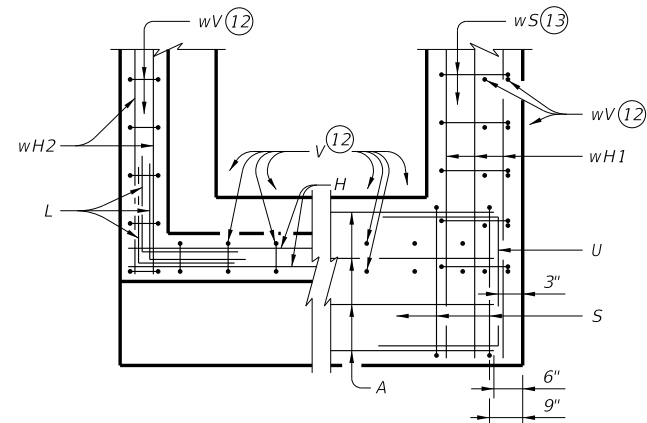

BACKWALL CAP
CORNER DETAILS

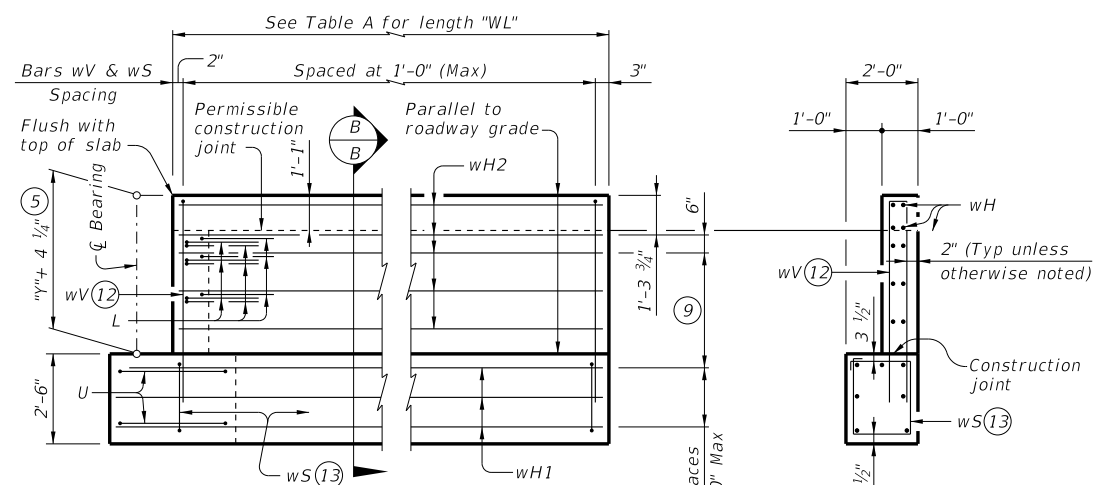

WINGWALL ELEVATION

SECTION B-B

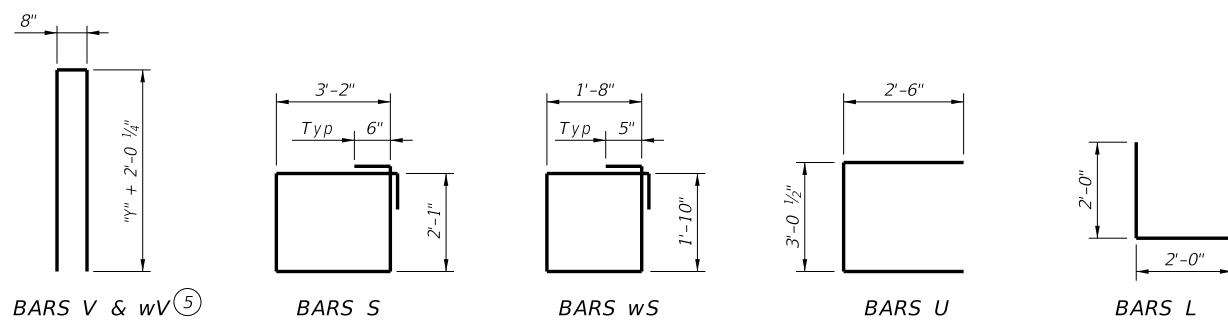

BARS V & wV

BARS S

BARS wS

BARS U

BARS L

- ⑤ See Span Details for "Y" value.
- ⑦ Omit Dowels D at end of multi-span unit. Adjust reinforcing steel total accordingly.
- ⑨ Spacing based on beam type:
XB20 ~ 2 spaces at 1'-0" Max
XB28 ~ 3 spaces at 1'-0" Max
XB34 ~ 3 spaces at 1'-0" Max
XB40 ~ 3 spaces at 1'-0" Max
- ⑫ Field bend as needed to clear piles.
- ⑬ Adjust as required to avoid piling.
- ⑭ Quantities shown are for one abutment only (with approach slab.) With no approach slab, add 1.8 CY Class C concrete and 274 lbs of reinforcing steel for 4 additional H bars.

TABLES OF ESTIMATED QUANTITIES WITH 2:1 HEADER SLOPE ⑭

TYPE 5XB20 BEAMS					TYPE 5XB28 BEAMS					TYPE 5XB34 BEAMS					TYPE 5XB40 BEAMS								
Bar	No.	Size	Length	Weight	Bar	No.	Size	Length	Weight	Bar	No.	Size	Length	Weight	Bar	No.	Size	Length	Weight				
A	10	#11	45'-0"	2,391	A	10	#11	45'-0"	2,391	A	10	#11	45'-0"	2,391	A	10	#11	45'-0"	2,391				
D	2	#9	1'-8"	11	D	2	#9	1'-8"	11	D	2	#9	1'-8"	11	D	2	#9	1'-8"	11				
H	6	#6	45'-8"	412	H	8	#6	45'-8"	549	H	8	#6	45'-8"	549	H	8	#6	45'-8"	549				
L	18	#6	4'-0"	108	L	18	#6	4'-0"	108	L	18	#6	4'-0"	108	L	18	#6	4'-0"	108				
S	48	#5	11'-6"	576	S	48	#5	11'-6"	576	S	48	#5	11'-6"	576	S	48	#5	11'-6"	576				
U	4	#6	8'-1"	49	U	4	#6	8'-1"	49	U	4	#6	8'-1"	49	U	4	#6	8'-1"	49				
V	45	#5	10'-0"	469	V	45	#5	11'-3"	528	V	45	#5	12'-6"	587	V	45	#5	13'-3"	622				
wH1	14	#6	8'-5"	177	wH1	14	#6	9'-5"	198	wH1	14	#6	10'-5"	219	wH1	14	#6	11'-5"	240				
wH2	16	#6	6'-8"	160	wH2	20	#6	7'-8"	230	wH2	20	#6	8'-8"	260	wH2	20	#6	9'-8"	290				
wS	16	#4	7'-10"	84	wS	18	#4	7'-10"	94	wS	20	#4	7'-10"	105	wS	22	#4	7'-10"	115				
wV	16	#5	10'-0"	167	wV	18	#5	11'-3"	211	wV	20	#5	12'-6"	261	wV	22	#5	13'-3"	304				
Reinforcing Steel				Lb	4,604	Reinforcing Steel				Lb	4,945	Reinforcing Steel				Lb	5,116	Reinforcing Steel				Lb	5,255
Class "C" Concrete				CY	21.8	Class "C" Concrete				CY	23.8	Class "C" Concrete				CY	25.6	Class "C" Concrete				CY	27.5

TABLES OF ESTIMATED QUANTITIES WITH 3:1 HEADER SLOPE ⑭

TYPE 5XB20 BEAMS					TYPE 5XB28 BEAMS					TYPE 5XB34 BEAMS					TYPE 5XB40 BEAMS								
Bar	No.	Size	Length	Weight	Bar	No.	Size	Length	Weight	Bar	No.	Size	Length	Weight	Bar	No.	Size	Length	Weight				
A	10	#11	45'-0"	2,391	A	10	#11	45'-0"	2,391	A	10	#11	45'-0"	2,391	A	10	#11	45'-0"	2,391				
D	2	#9	1'-8"	11	D	2	#9	1'-8"	11	D	2	#9	1'-8"	11	D	2	#9	1'-8"	11				
H	6	#6	45'-8"	412	H	8	#6	45'-8"	549	H	8	#6	45'-8"	549	H	8	#6	45'-8"	549				
L	18	#6	4'-0"	108	L	18	#6	4'-0"	108	L	18	#6	4'-0"	108	L	18	#6	4'-0"	108				
S	48	#5	11'-6"	576	S	48	#5	11'-6"	576	S	48	#5	11'-6"	576	S	48	#5	11'-6"	576				
U	4	#6	8'-1"	49	U	4	#6	8'-1"	49	U	4	#6	8'-1"	49	U	4	#6	8'-1"	49				
V	45	#5	10'-0"	469	V	45	#5	11'-3"	528	V	45	#5	12'-6"	587	V	45	#5	13'-3"	622				
wH1	14	#6	11'-5"	240	wH1	14	#6	13'-5"	282	wH1	14	#6	14'-5"	303	wH1	14	#6	16'-5"	345				
wH2	16	#6	9'-8"	232	wH2	20	#6	11'-8"	350	wH2	20	#6	12'-8"	381	wH2	20	#6	14'-8"	441				
wS	22	#4	7'-10"	115	wS	26	#4	7'-10"	136	wS	28	#4	7'-10"	147	wS	32	#4	7'-10"	167				
wV	22	#5	10'-0"	229	wV	26	#5	11'-3"	305	wV	28	#5	12'-6"	365	wV	32	#5	13'-3"	442				
Reinforcing Steel				Lb	4,832	Reinforcing Steel				Lb	5,285	Reinforcing Steel				Lb	5,467	Reinforcing Steel				Lb	5,701
Class "C" Concrete				CY	23.6	Class "C" Concrete				CY	26.4	Class "C" Concrete				CY	28.3	Class "C" Concrete				CY	31.0

HL93 LOADING

SHEET 2 OF 2



ABUTMENTS
PRESTR CONC X-BEAMS
(TYPE 5XB20 THROUGH 5XB40)
44' ROADWAY
AXB-44

FILE: XB-AXB4400-22.dgn	DN: BMP	CK: EFC	DW: JER	CK: BMP
©TxDOT August 2022	CONT	SECT	JOB	HIGHWAY
REVISIONS	DIST	COUNTY	SHEET NO.	

DATE:
FILE: