

DISCLAIMER: The use of this standard is governed by the "Texas Engineering Practice Act." No warranty of any kind is made by TxDOT for any purpose whatsoever. TxDOT assumes no responsibility for the conversion of this standard to other formats or for incorrect results or damages resulting from its use.

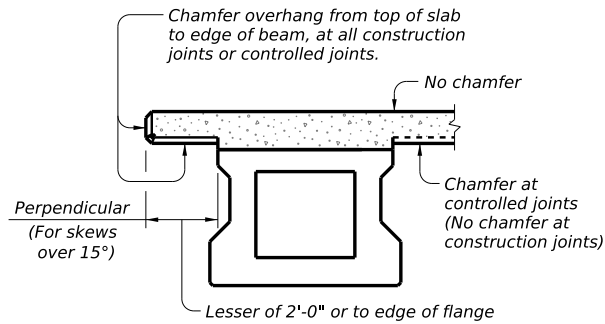

**CHAMFER LIMITS DETAIL ①**

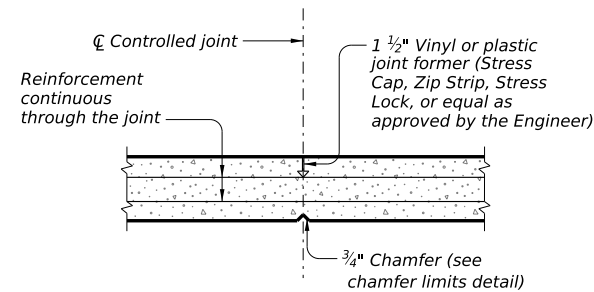

**CONTROLLED JOINT DETAIL**

(Saw-cutting is not allowed)

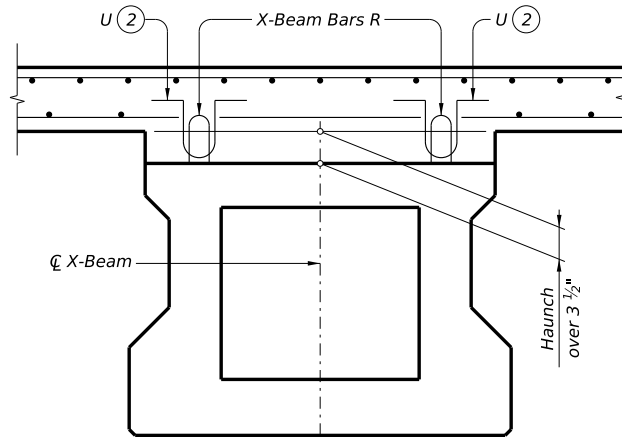

**HAUNCH REINFORCING DETAIL**

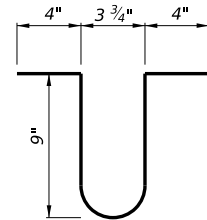

**BARS U (#4)**

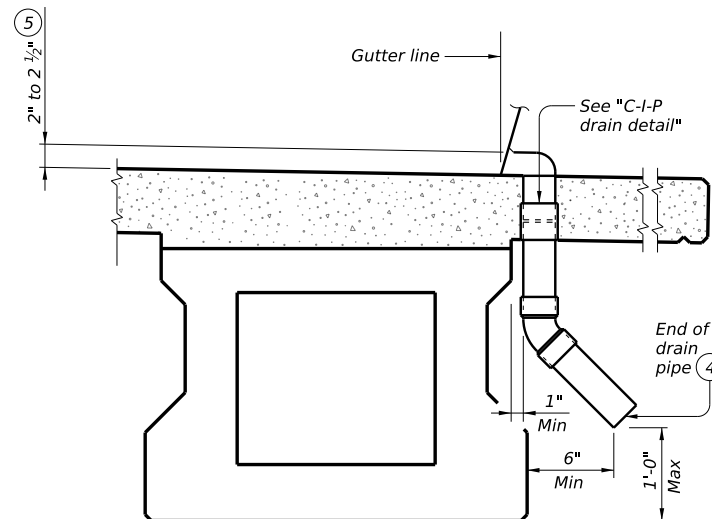

**DRAIN DETAIL ⑥**

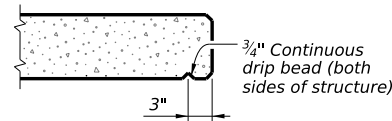

**DRIP BEAD DETAIL**

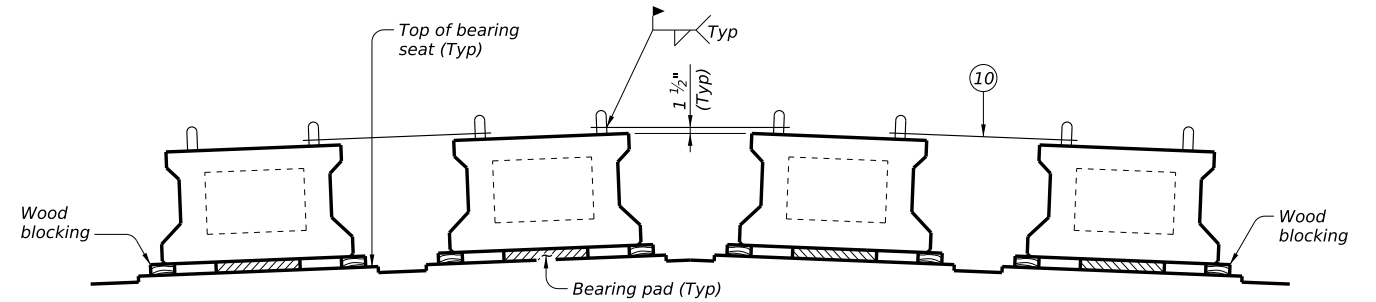

**MINIMUM BEAM BLOCKING & BRACING DETAIL**

Provide blocking at both sides of all beam ends supported by one bearing pad. Leave blocking in place for at least 4 days after slab is cast and afterwards remove at the Contractor's convenience.

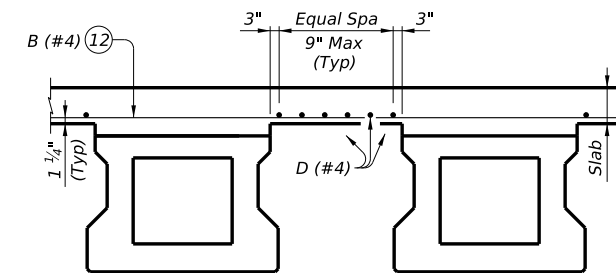

**TYPICAL TRANSVERSE SLAB SECTION WITHOUT PCP ⑪**

Top reinforcing steel not shown for clarity.

- ① See span details for type of joint and joint locations.
- ② Space Bars U with beam Bars R in all areas where measured haunch exceeds 3 1/2".
- ③ Roughen outside of PVC with coarse rasp or equal to ensure bond with cast-in-place concrete.
- ④ Water may not be discharged onto beams.
- ⑤ Drain entrance formed in rail or sidewalk.
- ⑥ All drain pipe and fittings to be 4" diameter (Sch 40) PVC. See Item 481, "Pipe for Drains" for pipe, connections and solvent welding. Bend reinforcing steel to clear PVC 1". Drain length and location is as directed by the Engineer. Drains are not permitted over roadways or railways, or within 10'-0" of bent caps. Degrease outside of exposed PVC, apply acrylic water base primer, then coat with same surface finishing material as used for outside beam face. Variations of the above designs, as required for the type of rail used and its location on the structure, may be installed with the approval and direction of the Engineer.
- ⑦ Class 7 silicone sealant that conforms to DMS-6310. Install when ambient temperature is between 55°F and 85°F and rising. Engineer to determine allowable hours for sealant application.
- ⑧ 1 1/4" backer rod must be compatible with joint sealant. Use of multiple pieces to create a backer rod cross section is not permitted. Top of backer rod must be convex as shown.
- ⑨ The maximum distance between Type A expansion joints is 100'. See Bridge Layout for location of joints.
- ⑩ Weld a (#5) bar at each beam end as shown immediately after erection and prior to PCP placement. These bars are in addition to slab reinforcement.
- ⑪ Provide Grade 60 reinforcing steel. Provide laps, where required, as follows:  
Uncoated ~ #4 = 1'-7"  
Epoxy coated ~ #4 = 2'-5"
- ⑫ Bars B (#4) spaced at 9" Max with 2" end cover. Overhang option, Contractor may end alternating Bars B (#4) at centerline outside girder.

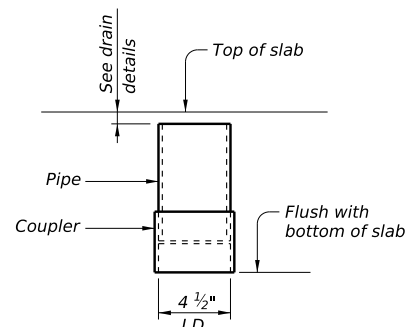

**C-I-P DRAIN DETAIL ③**

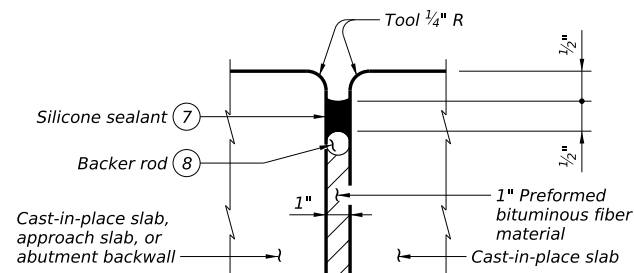

**TYPE A JOINT DETAIL ⑨**

**GENERAL NOTES:**

Designed in accordance with AASHTO LRFD Specifications. Payment for Type A joint will be as per Item 454, "Bridge Expansion Joints."  
All other items (reinforcing steel, drains, joint formers, etc.) shown on this sheet are subsidiary to other bid items.  
Systems equal to or better than those shown may be used provided details of such systems are submitted to and approved by the Engineer prior to erection.  
Use of these systems and/or details does not relieve the Contractor of the responsibility for the adequacy of the bracing and the safety of the structure.

Cover dimensions are clear dimensions, unless noted otherwise. Reinforcing bar dimensions shown are out-to-out of bar.

		<b>Bridge Division Standard</b>	
<b>MINIMUM ERECTION AND BRACING REQUIREMENTS WITH MISC. SLAB DETAILS PRESTRESSED CONCRETE X-BEAMS XBRR-MS</b>			
FILE: XB-XBRRMS-24.dgn	DN: JMH	CK: TAR	DW: JER
©TxDOT August 2022	CONT	SECT	JOB
REVISIONS			HIGHWAY
11-24: Flipped top mat.	DIST	COUNTY	SHEET NO.

DATE: FILE: