

DISCLAIMER: The use of this standard is governed by the "Texas Engineering Practice Act". No warranty of any kind is made by TxDOT for any purpose whatsoever. TxDOT assumes no responsibility for the conversion of this standard to other formats or for incorrect results or damages resulting from its use.

DATE: FILE:

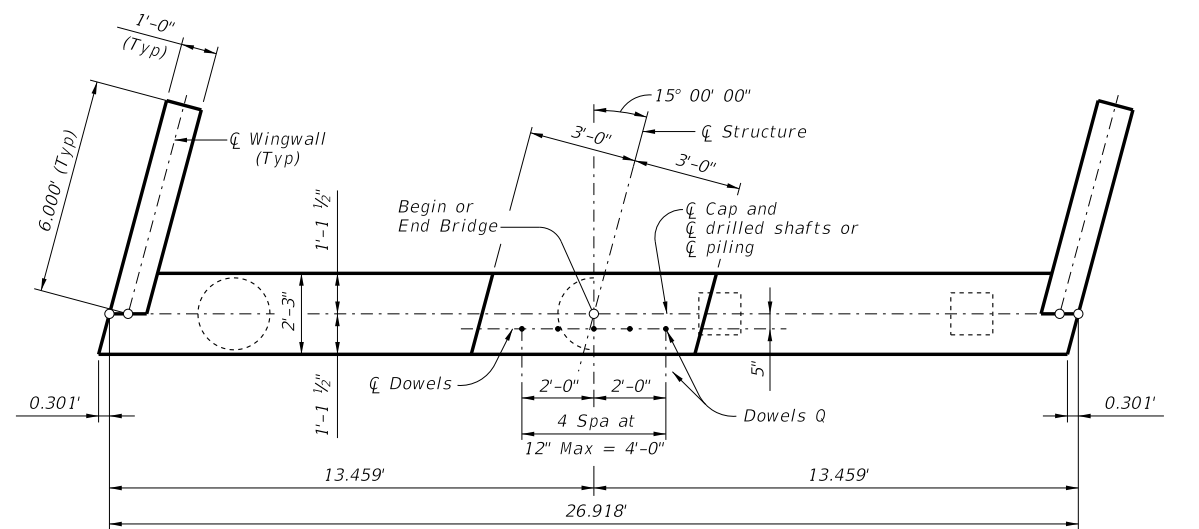

SHOWING DRILLED SHAFTS      SHOWING PILES

**PLAN**

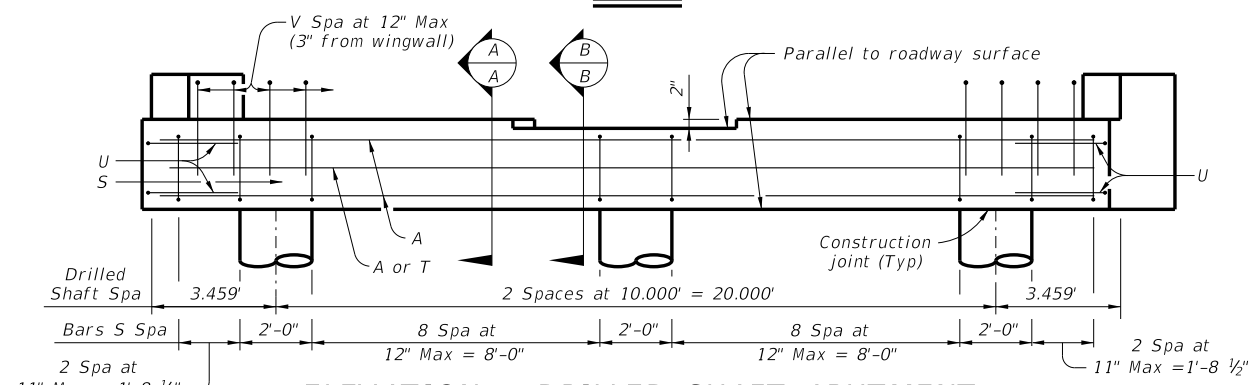

**ELEVATION ~ DRILLED SHAFT ABUTMENT**

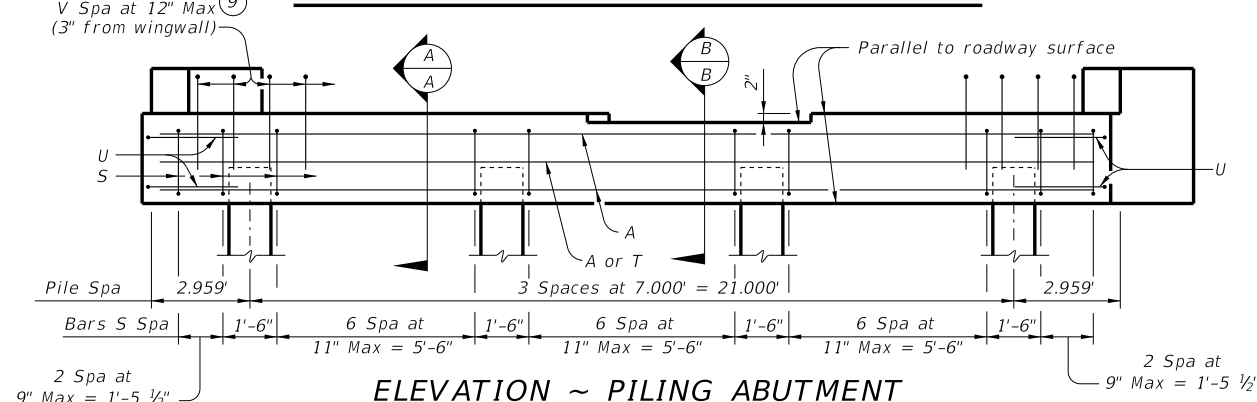

**ELEVATION ~ PILING ABUTMENT**

Note: For piling larger than 16", adjust Bars S as required to avoid piling.

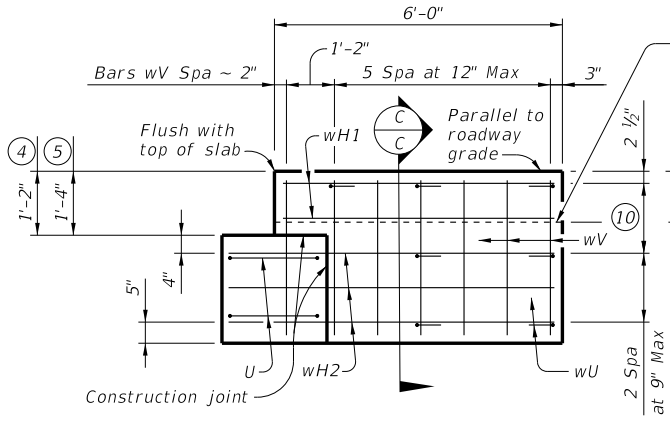
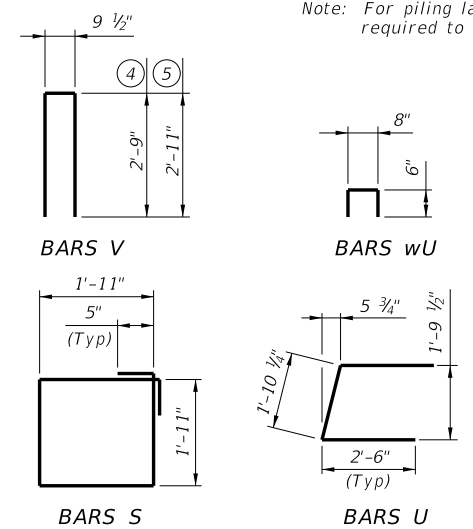

**WINGWALL ELEVATION**

- ① Quantities shown are for one abutment only (with approach slab). Without approach slab, add 55 Lbs reinforcing steel for 2 - #5 Bars H (26'-7") and the following amounts of concrete: 14" slab thickness add 1.2 CY Class "C" Concrete. 16" slab thickness add 1.4 CY Class "C" Concrete.
- ② Increase as required to maintain 3" from finished grade.
- ③ See Bridge Layout to determine if approach slab is present.
- ④ Use with 14" slab thickness.
- ⑤ Use with 16" slab thickness.
- ⑥ Omit Bars H if approach slab is present.
- ⑦ See CS-MD standard for preformed bituminous fiber material.
- ⑧ Omit bottom center Bar A for Piling Abutment.
- ⑨ Field bend as needed to clear piles.
- ⑩ Spacing based on slab depth 14" ~ 2 spaces at 8" Max. 16" ~ 2 spaces at 9" Max.

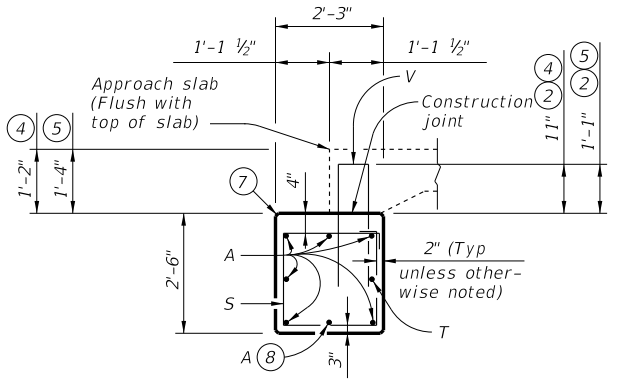

**SECTION A-A** (With approach slab)

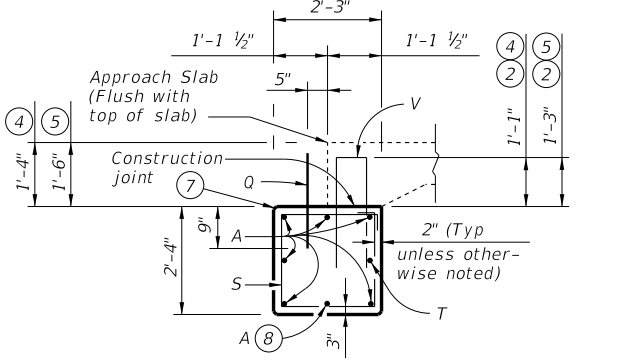

**SECTION B-B** (With approach slab)

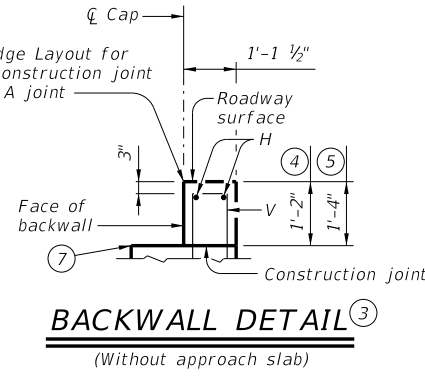

**BACKWALL DETAIL** (Without approach slab)

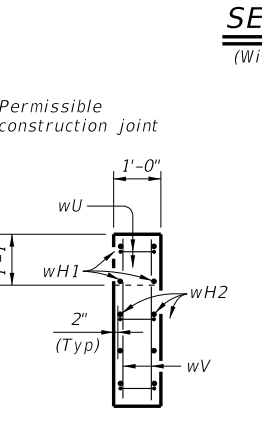

**SECTION C-C**

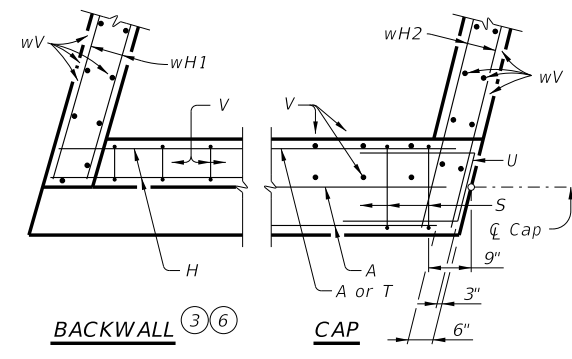

**BACKWALL**      **CAP**

**14" SLAB ~ TABLE OF ESTIMATED QUANTITIES**

DRILLED SHAFT ABUT					PILING ABUTMENT						
Bar	No.	Size	Length	Weight	Bar	No.	Size	Length	Weight		
A	7	#11	25'-11"	964	A	6	#11	25'-11"	826		
Q	5	#6	1'-6"	11	Q	5	#6	1'-6"	11		
S	24	#4	8'-6"	136	S	27	#4	8'-6"	153		
T	1	#5	25'-11"	27	T	1	#5	25'-11"	27		
U	4	#6	6'-10"	41	U	4	#6	6'-10"	41		
V	26	#5	6'-4"	172	V	26	#5	6'-4"	172		
wH1	8	#6	5'-8"	68	wH1	8	#6	5'-8"	68		
wH2	12	#6	6'-10"	123	wH2	12	#6	6'-10"	123		
wU	14	#4	1'-8"	16	wU	14	#4	1'-8"	16		
wV	28	#5	3'-4"	97	wV	28	#5	3'-4"	97		
Reinforcing Steel				Lb	1,655	Reinforcing Steel				Lb	1,534
Cl "C" Conc (Abut)				CY	6.9	Cl "C" Conc (Abut)				CY	6.9

**16" SLAB ~ TABLE OF ESTIMATED QUANTITIES**

DRILLED SHAFT ABUT					PILING ABUTMENT						
Bar	No.	Size	Length	Weight	Bar	No.	Size	Length	Weight		
A	7	#11	25'-11"	964	A	6	#11	25'-11"	826		
Q	5	#6	1'-6"	11	Q	5	#6	1'-6"	11		
S	24	#4	8'-6"	136	S	27	#4	8'-6"	153		
T	1	#5	25'-11"	27	T	1	#5	25'-11"	27		
U	4	#6	6'-10"	41	U	4	#6	6'-10"	41		
V	26	#5	6'-8"	181	V	26	#5	6'-8"	181		
wH1	8	#6	5'-8"	68	wH1	8	#6	5'-8"	68		
wH2	12	#6	6'-10"	123	wH2	12	#6	6'-10"	123		
wU	14	#4	1'-8"	16	wU	14	#4	1'-8"	16		
wV	28	#5	3'-6"	102	wV	28	#5	3'-6"	102		
Reinforcing Steel				Lb	1,669	Reinforcing Steel				Lb	1,548
Cl "C" Conc (Abut)				CY	7.0	Cl "C" Conc (Abut)				CY	7.0

**MATERIAL NOTES:**  
 Provide Class C concrete (f'c = 3,600 psi).  
 Provide Class C (HPC) concrete if shown elsewhere in the plans.  
 Provide Grade 60 reinforcing steel.

**GENERAL NOTES:**  
 Designed according to AASHTO LRFD Bridge Design Specifications. Details shown are for right forward skew. See Bridge Layout for actual skew direction.  
 Designed for normal embankment header slope of 3:1. See Bridge Layout for foundation type, size and length. See Common Foundation Details (FD) standard sheet for foundation details and notes.  
 See Concrete Riprap (CRR) standard sheet or Stone Riprap (SRR) standard sheets for riprap attachment details, if applicable. See applicable rail details for anchorage in wingwalls. See Miscellaneous Details for C-I-P Concrete Slab Spans (CS-MD) standard sheet for joint details and details not shown. Calculated Foundation Loads: 35 Tons/drilled shaft 25 Tons/pile.  
 These abutment details may be used with standards CS-25-24, CS-50-24-15, CS-75-24-15, and CS-80-24-15 only.

Cover dimensions are clear dimensions, unless noted otherwise. Reinforcing bar dimensions shown are out-to-out of bar.

HL93 LOADING

**Bridge Division Standard**

**ABUTMENTS FOR C-I-P CONC SLAB SPANS**

**24 FT ROADWAY      15° SKEW**

**ACS-24-15**

FILE: acs02ste-21.dgn	DN: HTP	CK: SDC	DW: LJC	CK: TAR
©TxDOT July 2021	CONT	SECT	JOB	HIGHWAY
REVISIONS				
	DIST	COUNTY		SHEET NO.