

DISCLAIMER: This standard is governed by the "Texas Engineering Practice Act". No warranty of any kind is made by TxDOT for any purpose whatsoever. TxDOT assumes no responsibility for the conversion of this standard to other formats or for incorrect results or damages resulting from its use.

DATE: FILE:

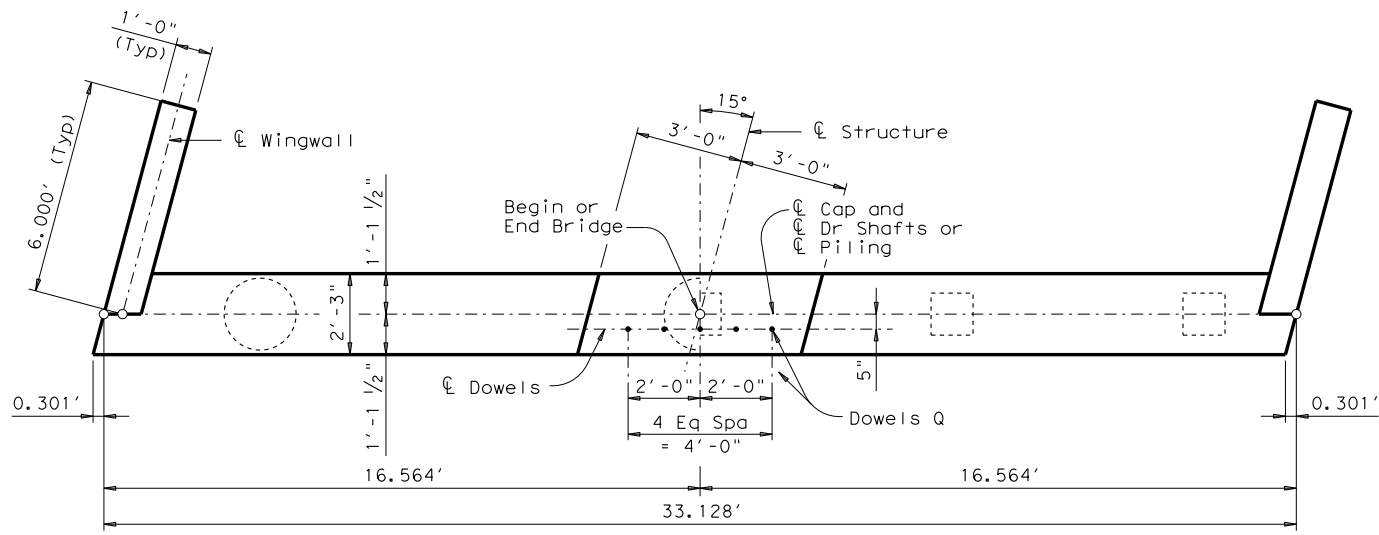

SHOWING DRILLED SHAFTS

SHOWING PILES

PLAN

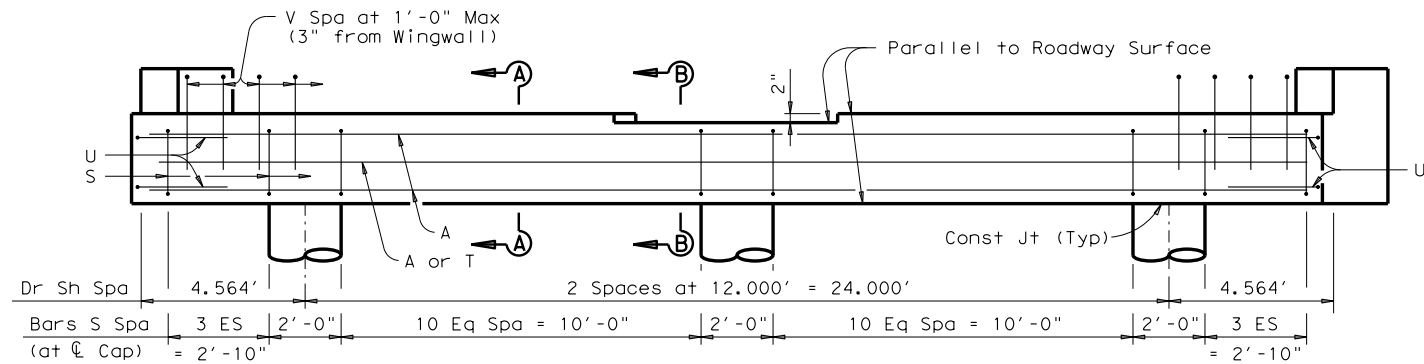

ELEVATION ~ DRILLED SHAFT ABUTMENT

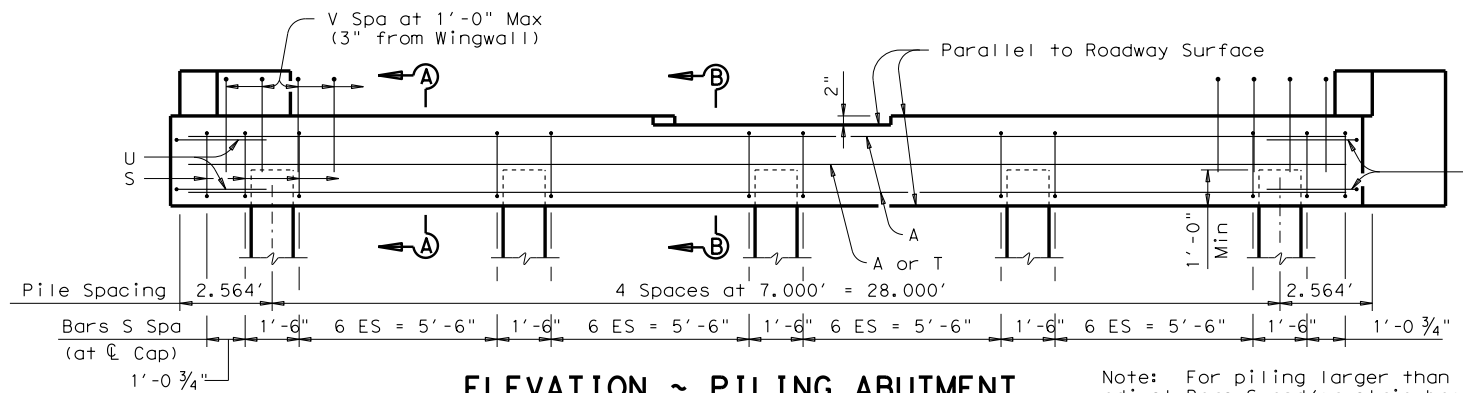

ELEVATION ~ PILING ABUTMENT

Note: For piling larger than 16", adjust Bars S and/or strip back piling as required to clear cap reinforcing.

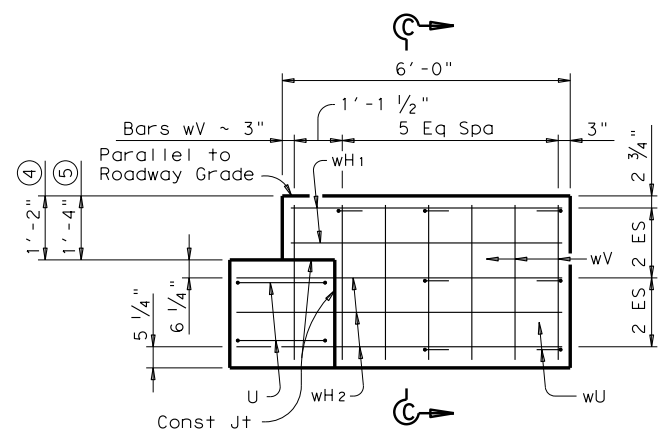

WINGWALL ELEVATION

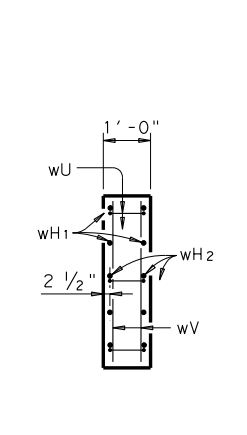

SECTION C-C

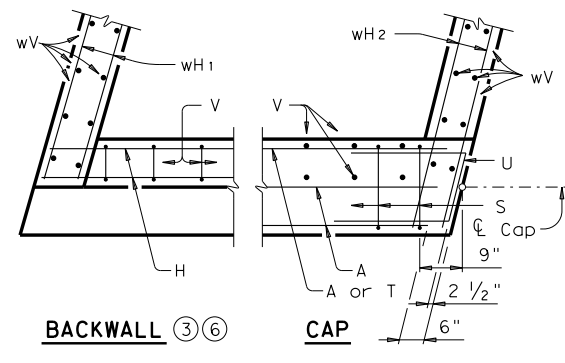

BACKWALL ③ ⑥

CAP

CORNER DETAILS

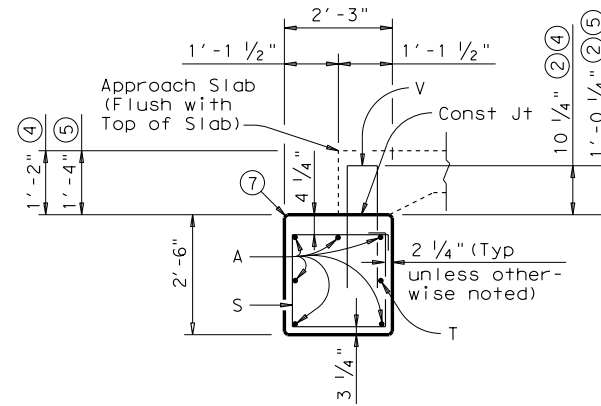

SECTION A-A ③

(With Approach Slab)

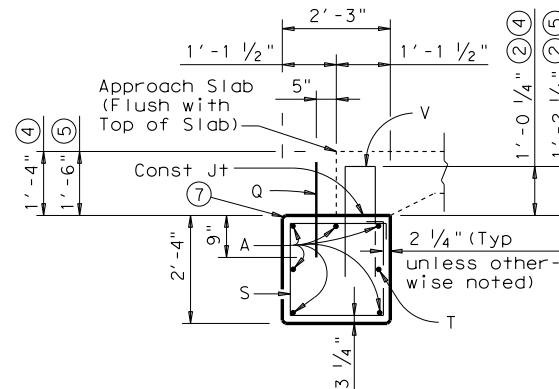

SECTION B-B ③

(With Approach Slab)

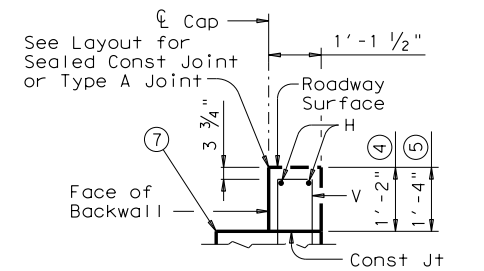

BACKWALL DETAIL ③

(Without Approach Slab)

Steel H piling (extend a Min 1'-0" into cap)

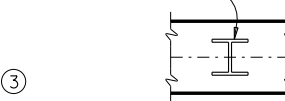

ORIENTATION OF STEEL H PILING

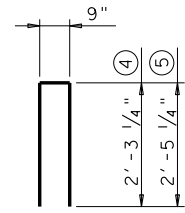

BARS V

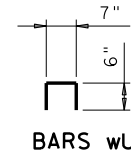

BARS wU

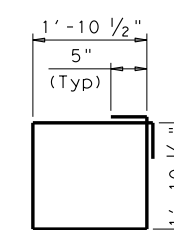

BARS S

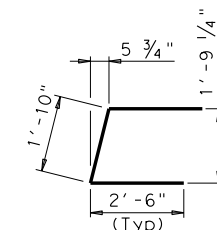

BARS U

14" SLAB ~ TABLE OF ESTIMATED QUANTITIES ①

DRILLED SHAFT ABUT					PILING ABUTMENT				
Bar	No.	Size	Length	Weight	Bar	No.	Size	Length	Weight
A	6	#11	32'-2"	1,025	A	6	#11	32'-2"	1,025
Q	5	#6	1'-6"	11	Q	5	#6	1'-6"	11
S	30	#4	8'-4"	167	S	32	#4	8'-4"	178
T	1	#5	32'-2"	34	T	1	#5	32'-2"	34
U	4	#6	6'-10"	41	U	4	#6	6'-10"	41
V	32	#5	5'-4"	178	V	32	#5	5'-4"	178
wH1	8	#6	5'-8"	68	wH1	8	#6	5'-8"	68
wH2	12	#6	6'-10"	123	wH2	12	#6	6'-10"	123
wU	14	#4	1'-7"	15	wU	14	#4	1'-7"	15
wV	28	#5	3'-4"	97	wV	28	#5	3'-4"	97
Reinforcing Steel				Lb 1,759	Reinforcing Steel				Lb 1,770
Class "C" Concrete				CY 8.2	Class "C" Concrete				CY 8.2

16" SLAB ~ TABLE OF ESTIMATED QUANTITIES ①

DRILLED SHAFT ABUT					PILING ABUTMENT				
Bar	No.	Size	Length	Weight	Bar	No.	Size	Length	Weight
A	6	#11	32'-2"	1,025	A	6	#11	32'-2"	1,025
Q	5	#6	1'-6"	11	Q	5	#6	1'-6"	11
S	30	#4	8'-4"	167	S	32	#4	8'-4"	178
T	1	#5	32'-2"	34	T	1	#5	32'-2"	34
U	4	#6	6'-10"	41	U	4	#6	6'-10"	41
V	32	#5	5'-8"	189	V	32	#5	5'-8"	189
wH1	8	#6	5'-8"	68	wH1	8	#6	5'-8"	68
wH2	12	#6	6'-10"	123	wH2	12	#6	6'-10"	123
wU	14	#4	1'-7"	15	wU	14	#4	1'-7"	15
wV	28	#5	3'-6"	102	wV	28	#5	3'-6"	102
Reinforcing Steel				Lb 1,775	Reinforcing Steel				Lb 1,786
Class "C" Concrete				CY 8.3	Class "C" Concrete				CY 8.3

① Quantities shown are for one Abutment only (with Approach Slab). With no Approach Slab, add 68 Lbs Reinforcing Steel for 2 ~ #5 Bars H (32'-10") and the following amounts of concrete:  
14" slab thickness add 1.5 CY Class "C" Concrete.  
16" slab thickness add 1.7 CY Class "C" Concrete.

- ② Increase as required to maintain 3 3/4" from Finished Grade.
- ③ See Layout to determine if Approach Slab is present.
- ④ Use with 14" slab thickness.
- ⑤ Use with 16" slab thickness.
- ⑥ Omit Bars H if Approach Slab is present.
- ⑦ See standard CS-MD for Preformed Bituminous Fiber Material.

GENERAL NOTES:

Designed according to AASHTO LRFD Specifications. Details shown are for right forward skew. See layout for actual skew direction. All cap and wall reinforcing shall be Grade 60. Concrete strength f'c = 3,600 psi. Designed for normal embankment header slope of 3:1. See Layout for foundation type, size and length. See standard FD for foundation details and notes. See standard CS-MD for joint details and details not shown. Calculated Foundation Loads: 40 Tons/Drilled Shaft 25 Tons/Pile. These abutment details may be used with standards CS-25-30, CS-50-30-15, CS-75-30-15 and CS-80-30-15 only.

HL93 LOADING

		<b>Bridge Division Standard</b>	
<b>ABUTMENTS FOR C-I-P CONC SLAB SPANS</b>			
<b>30 FT ROADWAY</b>		<b>15° SKEW</b>	
<b>ACS-30-15</b>			
FILE: acs10ste.dgn	DN: TxDOT	CK: TxDOT	DW: TxDOT
©TxDOT March 2009	CONT	SECT	JOB
REVISIONS			HIGHWAY
	DIST	COUNTY	SHEET NO.