

DISCLAIMER: The use of this standard is governed by the "Texas Engineering Practice Act". No warranty of any kind is made by TxDOT for any purpose whatsoever. TxDOT assumes no responsibility for the conversion of this standard to other formats or for incorrect results or damages resulting from its use.

DATE: FILE:

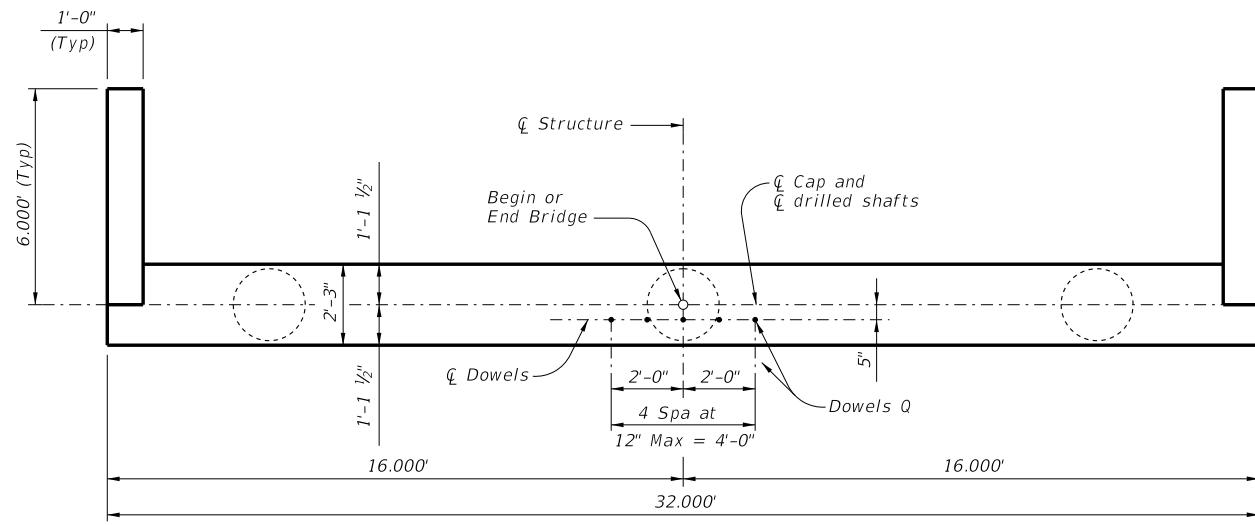

**PLAN**

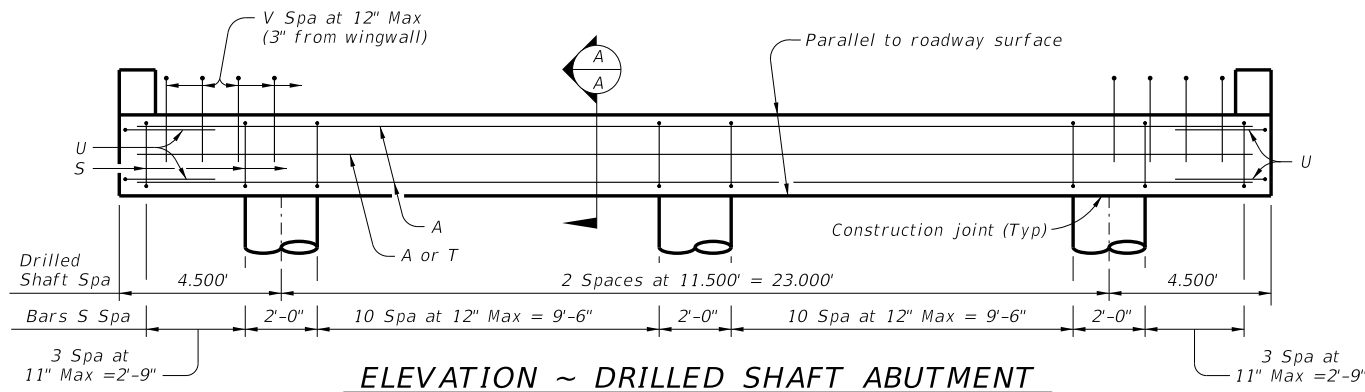

**ELEVATION ~ DRILLED SHAFT ABUTMENT**

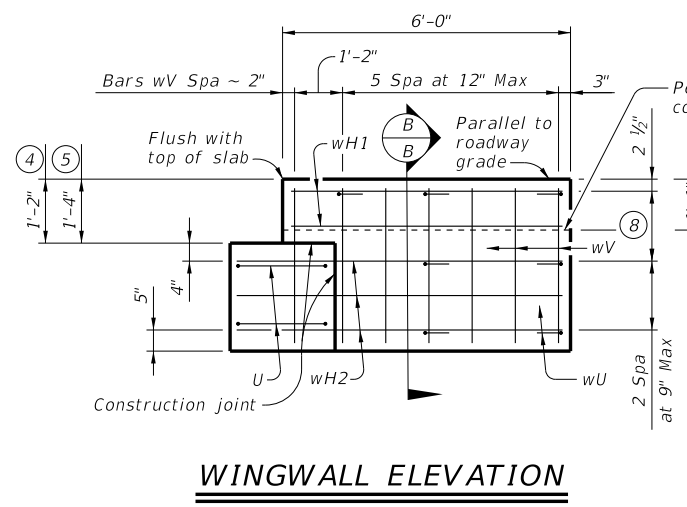
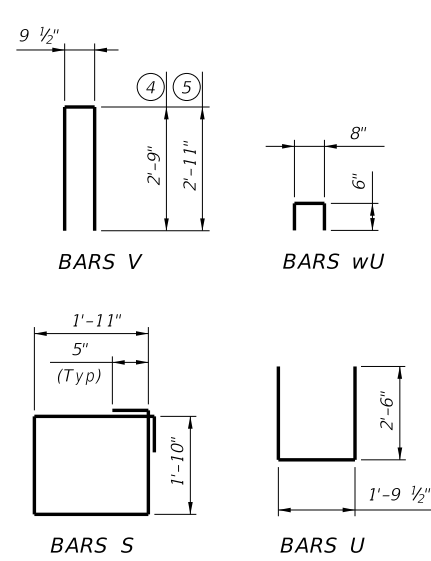

**WINGWALL ELEVATION**

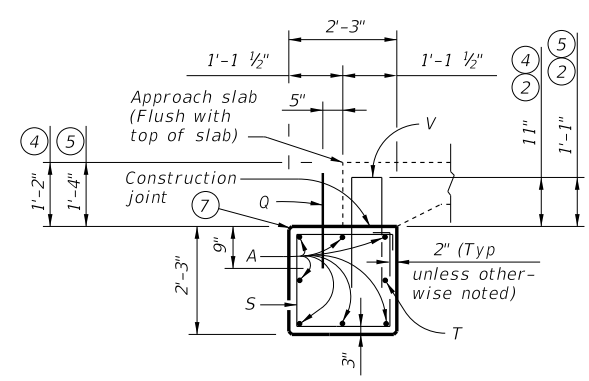

**SECTION A-A**  
(With approach slab)

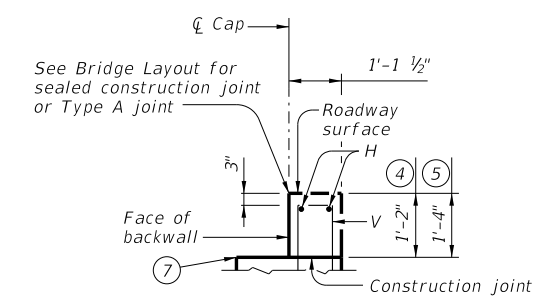

**BACKWALL DETAIL**  
(Without approach slab)

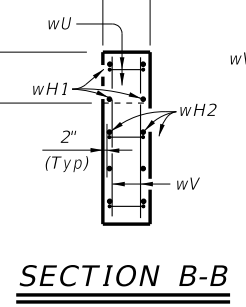

**SECTION B-B**

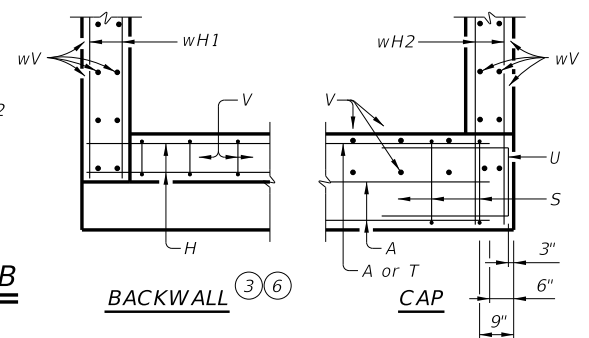

**CORNER DETAILS**

**TABLE OF ESTIMATED QUANTITIES**

14" SLAB					16" SLAB						
Bar	No.	Size	Length	Weight	Bar	No.	Size	Length	Weight		
A	7	#11	31'-0"	1,153	A	7	#11	31'-0"	1,153		
Q	5	#6	1'-6"	11	Q	5	#6	1'-6"	11		
S	30	#4	8'-4"	167	S	30	#4	8'-4"	167		
T	1	#5	31'-0"	32	T	1	#5	31'-0"	32		
U	4	#6	6'-10"	41	U	4	#6	6'-10"	41		
V	31	#5	6'-4"	205	V	31	#5	6'-8"	216		
wH1	8	#6	5'-8"	68	wH1	8	#6	5'-8"	68		
wH2	12	#6	6'-10"	123	wH2	12	#6	6'-10"	123		
wU	14	#4	1'-8"	16	wU	14	#4	1'-8"	16		
wV	28	#5	3'-1"	90	wV	28	#5	3'-3"	95		
Reinforcing Steel				Lb	1,906	Reinforcing Steel				Lb	1,922
CI "C" Conc (Abut)				CY	7.3	CI "C" Conc (Abut)				CY	7.4

- Quantities shown are for one abutment only (with approach slab). Without approach slab, add 66 Lbs reinforcing steel for 2 ~ #5 Bars H (31'-8") and the following amounts of concrete:  
14" slab thickness add 1.5 CY Class "C" Concrete.  
16" slab thickness add 1.7 CY Class "C" Concrete.
- Increase as required to maintain 3" from finished grade.
- See Bridge Layout to determine if approach slab is present.
- Use with 14" slab thickness.
- Use with 16" slab thickness.
- Omit Bars H if approach slab is present.
- See CS-MD standard for preformed bituminous fiber material.
- Spacing based on slab depth  
14" ~ 2 spaces at 8" Max.  
16" ~ 2 spaces at 9" Max.

**MATERIAL NOTES:**

Provide Class C concrete ( $f'c = 3,600$  psi).  
Provide Class C (HPC) concrete if shown elsewhere in the plans.  
Provide Grade 60 reinforcing steel.

**GENERAL NOTES:**

Designed according to AASHTO LRFD Bridge Design Specifications.  
Designed for normal embankment header slope of 3:1.  
See Bridge Layout for foundation type, size and length.  
See Common Foundation Details (FD) standard sheet for foundation details and notes.  
See Concrete Riprap (CRR) standard sheet or Stone Riprap (SRR) standard sheets for riprap attachment details, if applicable.  
See applicable rail details for anchorage in wingwalls.  
See Miscellaneous Details for C-I-P Concrete Slab Spans (CS-MD) standard sheet for joint details and details not shown.  
Calculated foundation loads: 40 Tons/drilled shaft  
These abutment details may be used with standards CS-25-30, CS-50-30, CS-75-30, and CS-80-30 only.

Cover dimensions are clear dimensions, unless noted otherwise.  
Reinforcing bar dimensions shown are out-to-out of bar.

HL93 LOADING

**Bridge Division Standard**

**ABUTMENTS FOR  
C-I-P CONC SLAB SPANS  
(DRILL SHAFTS)  
30 FT ROADWAY**

**ACSD-30**

FILE: acs11ste-21.dgn	DN: HTP	CK: SDC	DW: LIC	CK: TAR
©TxDOT	July 2021	CONT	SECT	JOB
REVISIONS		HIGHWAY		
DIST		COUNTY		SHEET NO.