

DISCLAIMER: The use of this standard is governed by the "Texas Engineering Practice Act". No warranty of any kind is made by TxDOT for any purpose whatsoever. TxDOT assumes no responsibility for the conversion of this standard to other formats or for incorrect results or damages resulting from its use.

DATE: FILE:

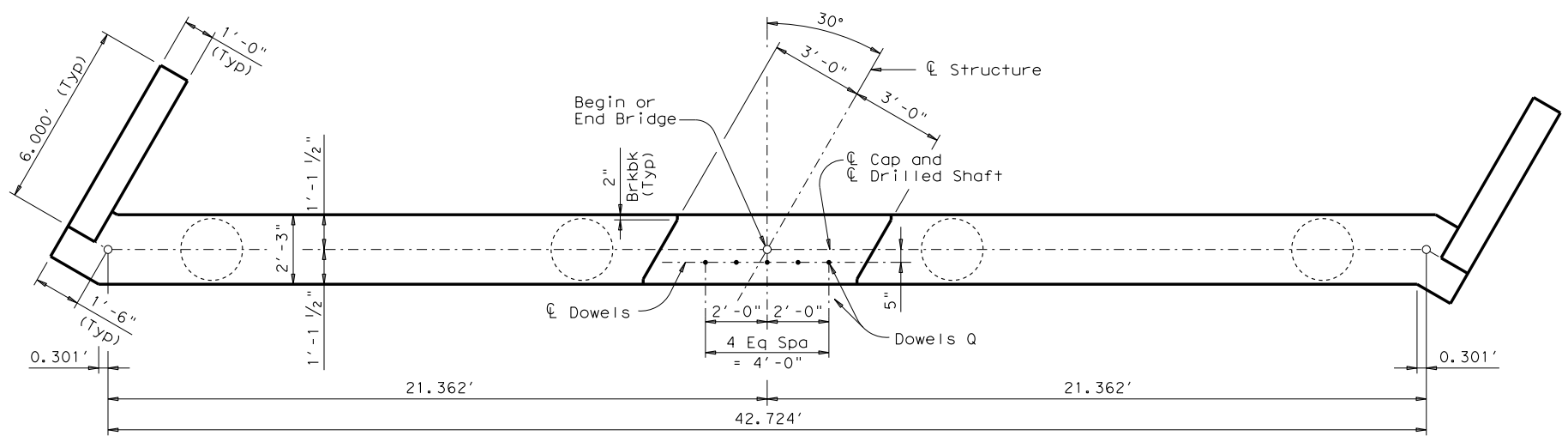

PLAN

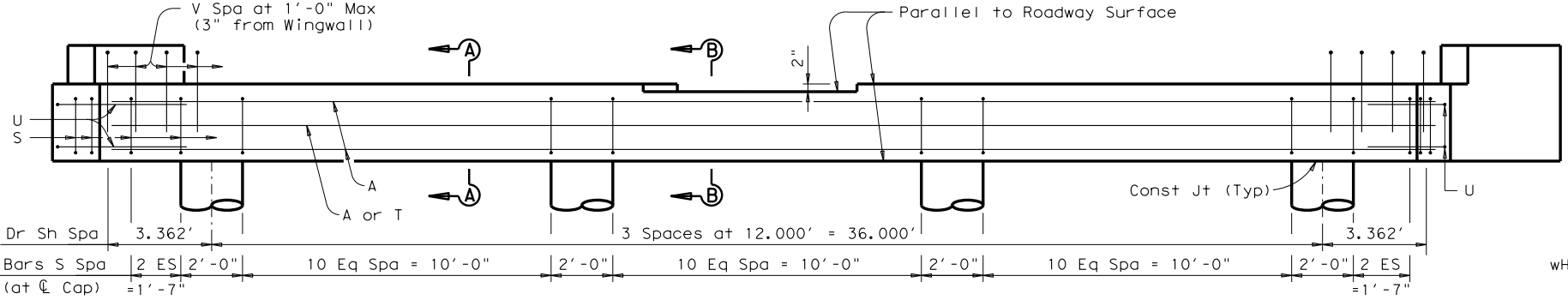

ELEVATION ~ DRILLED SHAFT ABUTMENT

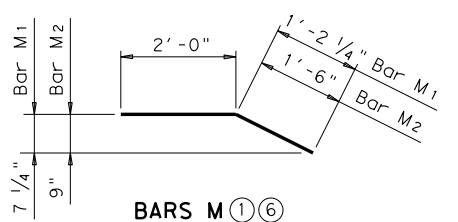

BARS M

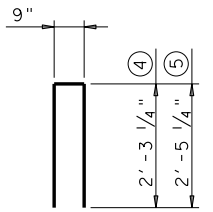

BARS V

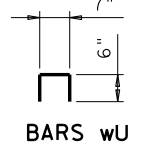

BARS wU

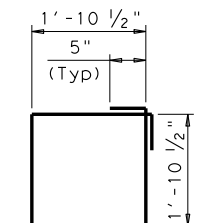

BARS S

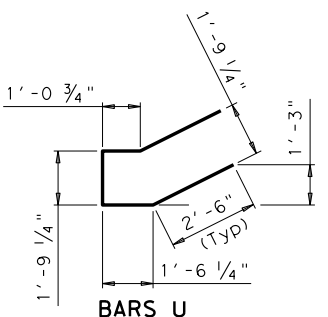

BARS U

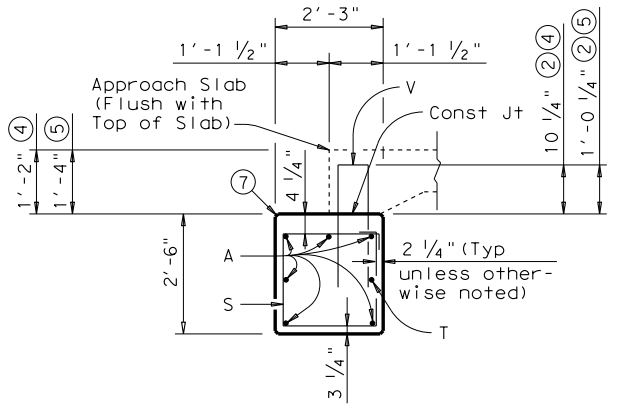

SECTION A-A (With Approach Slab)

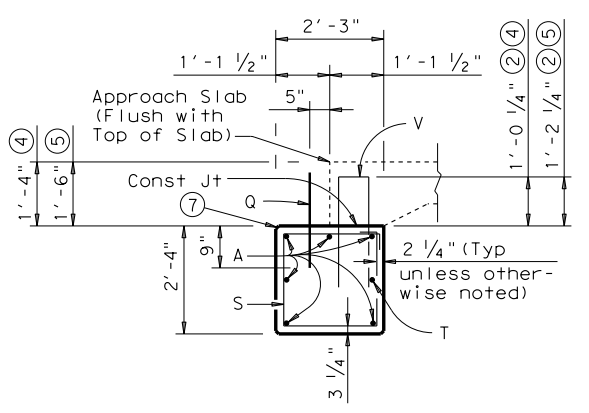

SECTION B-B (With Approach Slab)

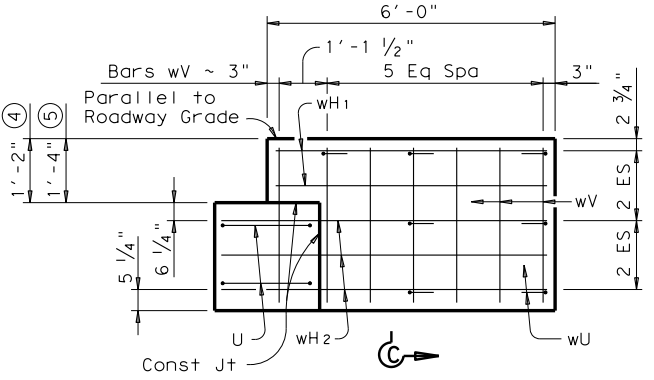

WINGWALL ELEVATION

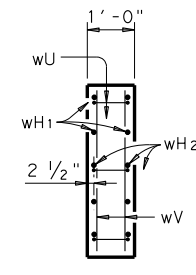

SECTION C-C

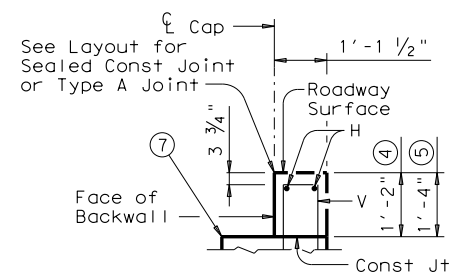

BACKWALL DETAIL (Without Approach Slab)

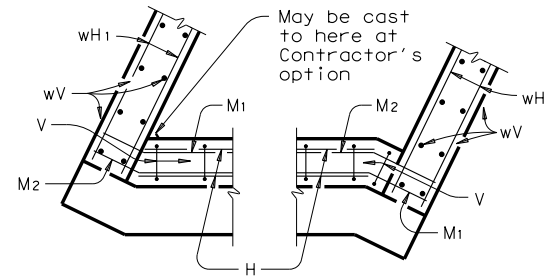

BACKWALL

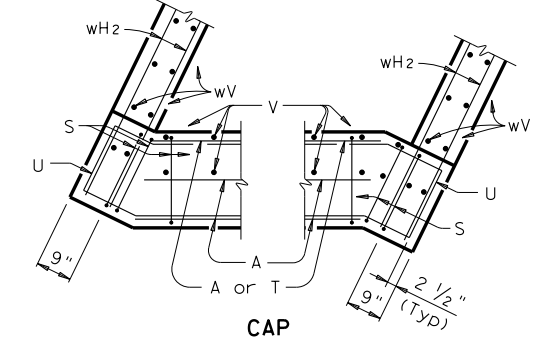

CAP CORNER DETAILS

TABLE OF ESTIMATED QUANTITIES											
14" SLAB					16" SLAB						
Bar	No.	Size	Length	Weight	Bar	No.	Size	Length	Weight		
A	6	#11	42'-9"	1,363	A	6	#11	42'-9"	1,363		
Q	5	#6	1'-6"	11	Q	5	#6	1'-6"	11		
S	43	#4	8'-4"	239	S	43	#4	8'-4"	239		
T	1	#5	42'-9"	45	T	1	#5	42'-9"	45		
U	4	#6	9'-4"	56	U	4	#6	9'-4"	56		
V	45	#5	5'-4"	250	V	45	#5	5'-8"	266		
wH1	8	#6	5'-8"	68	wH1	8	#6	5'-8"	68		
wH2	12	#6	6'-10"	123	wH2	12	#6	6'-10"	123		
wU	14	#4	1'-7"	15	wU	14	#4	1'-7"	15		
wV	28	#5	3'-4"	97	wV	28	#5	3'-6"	102		
Reinforcing Steel				Lb	2,267	Reinforcing Steel				Lb	2,288
Class "C" Concrete				CY	10.9	Class "C" Concrete				CY	10.9

- Quantities shown are for one Abutment only (with Approach Slab). With no Approach Slab, add 103 Lbs Total Reinforcing Steel for the following:  
 2 ~ #5 Bars H (42'-9")  
 2 ~ #5 Bars M1 (3'-2")  
 2 ~ #5 Bars M2 (3'-6")  
 Add the following amounts for concrete:  
 14" slab thickness add 2.1 CY Class "C" Concrete.  
 16" slab thickness add 2.4 CY Class "C" Concrete.
- Increase as required to maintain 3 3/4" from Finished Grade.
- See Layout to determine if Approach Slab is present.
- Use with 14" slab thickness.
- Use with 16" slab thickness.
- Omit Bars H and M if Approach Slab is present.
- See standard CS-MD for Preformed Bituminous Fiber Material.

**GENERAL NOTES:**  
 Designed according to AASHTO LRFD Specifications. Details shown are for right forward skew. See layout for actual skew direction. All cap and wall reinforcing shall be Grade 60. Concrete strength f'c = 3,600 psi. Designed for normal embankment header slope of 3:1. See Layout for foundation size and length. See standard FD for foundation details and notes. See standard CS-MD for joint details and details not shown. Calculated Foundation Loads: 40 Tons/Drilled Shaft. These abutment details may be used with standards CS-25-38, CS-50-38-30, CS-75-38-30 and CS-80-38-30 only.

HL93 LOADING

Texas Department of Transportation  
 Bridge Division Standard

**ABUTMENTS FOR  
 C-I-P CONC SLAB SPANS  
 (DRILLED SHAFTS)  
 38 FT ROADWAY 30° SKEW  
 ACSD-38-30**

FILE: acs17ste.dgn	DN: TxDOT	CK: TxDOT	DW: TxDOT	CK: TxDOT
©TxDOT March 2009	CONT	SECT	JOB	HIGHWAY
REVISIONS				
	DIST	COUNTY		SHEET NO.