

DISCLAIMER: The use of this standard is governed by the "Texas Engineering Practice Act". No warranty of any kind is made by TxDOT for any purpose whatsoever. TxDOT assumes no responsibility for the conversion of this standard to other formats or for incorrect results or damages resulting from its use.

DATE: FILE:

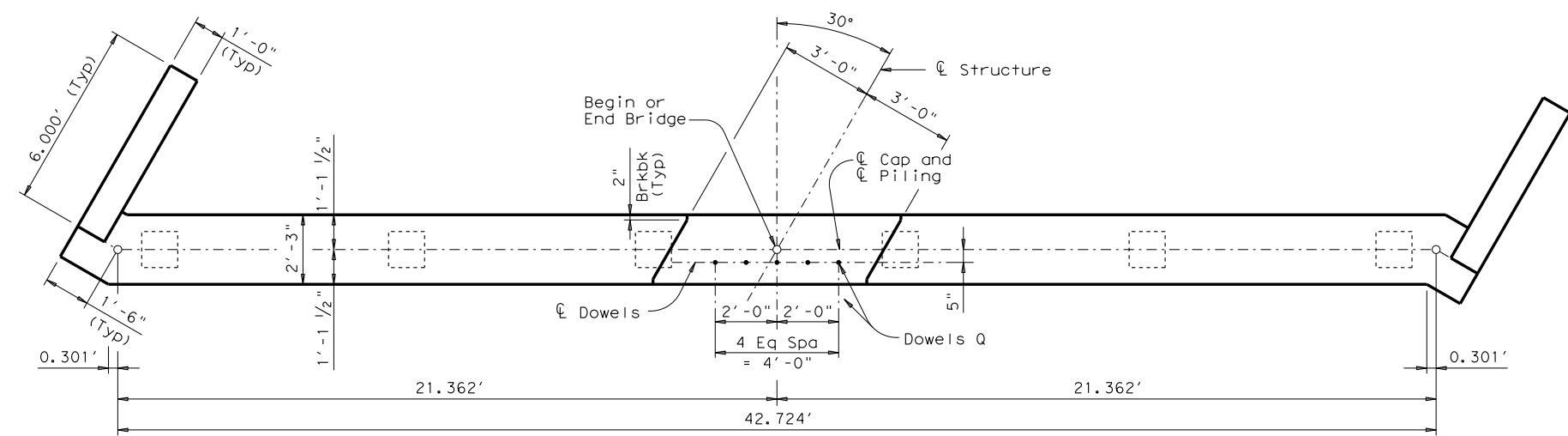

PLAN

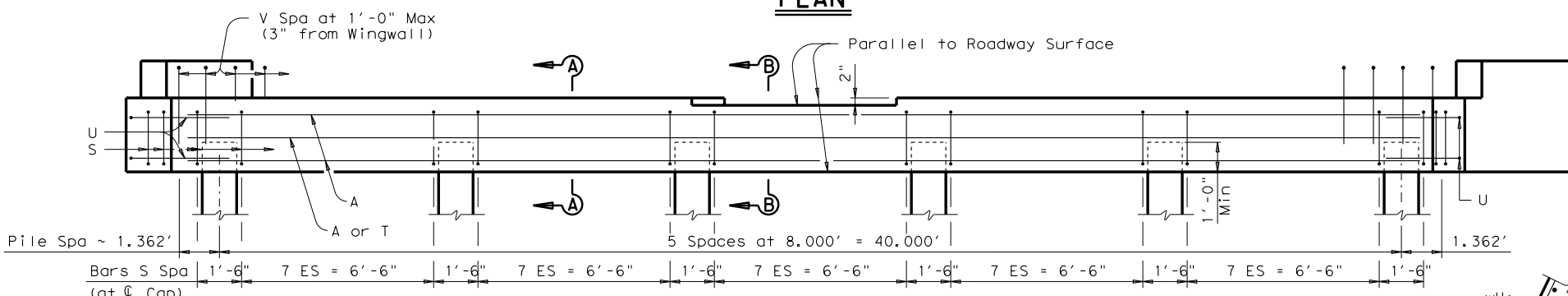

ELEVATION ~ PILING ABUTMENT

Note: For piling larger than 16", adjust Bars S and/or strip back piling as required to clear cap reinforcing.

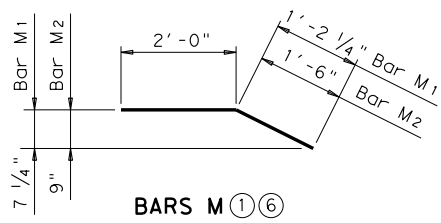

BARS M ①⑥

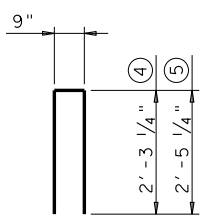

BARS V

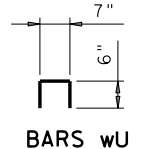

BARS wU

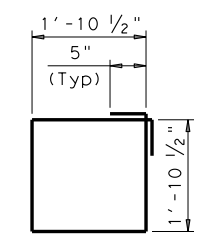

BARS S

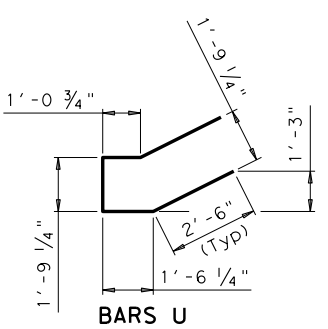

BARS U

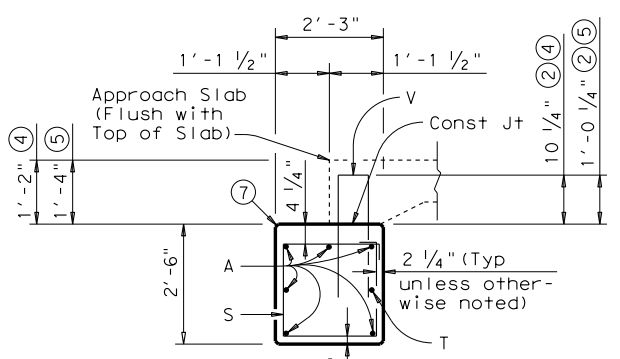

SECTION A-A ③
(With Approach Slab)

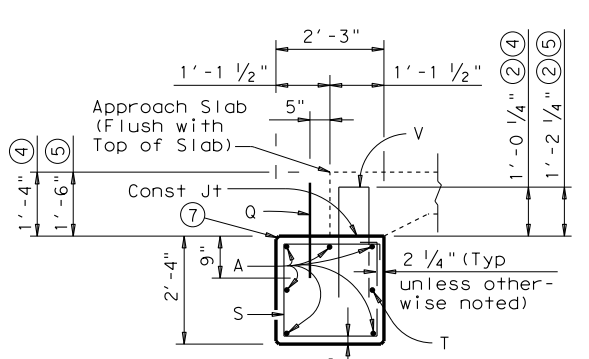

SECTION B-B ③
(With Approach Slab)

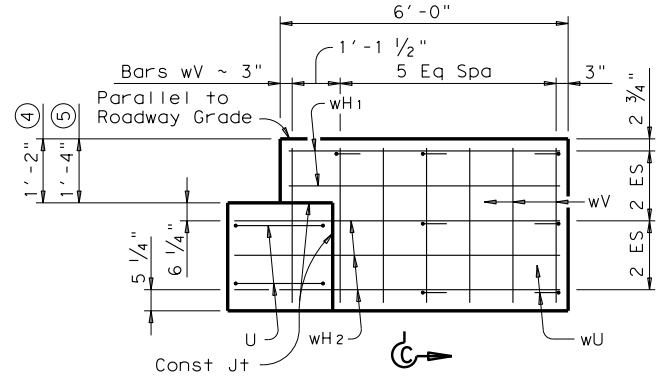

WINGWALL ELEVATION

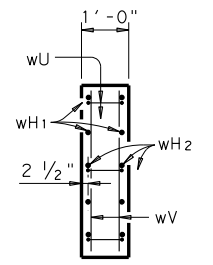

SECTION C-C

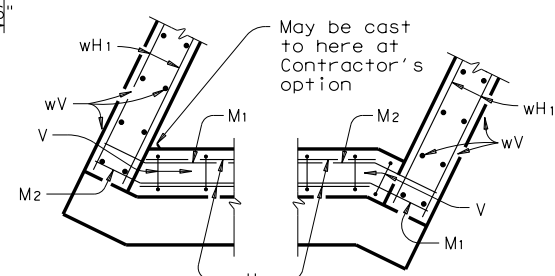

BACKWALL ③⑥

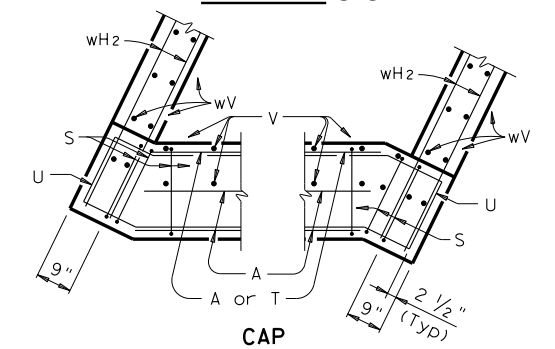

CAP CORNER DETAILS

Steel H piling (extend a Min 1'-0" into cap)

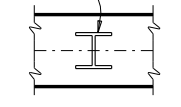

ORIENTATION OF STEEL H PILING

TABLE OF ESTIMATED QUANTITIES ①

| 14" SLAB | | | | | 16" SLAB | | | | | | |
|--------------------|-----|------|--------|--------|----------|--------------------|------|--------|--------|----|-------|
| Bar | No. | Size | Length | Weight | Bar | No. | Size | Length | Weight | | |
| A | 6 | #11 | 42'-9" | 1,363 | A | 6 | #11 | 42'-9" | 1,363 | | |
| Q | 5 | #6 | 1'-6" | 11 | Q | 5 | #6 | 1'-6" | 11 | | |
| S | 46 | #4 | 8'-4" | 256 | S | 46 | #4 | 8'-4" | 256 | | |
| T | 1 | #5 | 42'-9" | 45 | T | 1 | #5 | 42'-9" | 45 | | |
| U | 4 | #6 | 9'-4" | 56 | U | 4 | #6 | 9'-4" | 56 | | |
| V | 45 | #5 | 5'-4" | 250 | V | 45 | #5 | 5'-8" | 266 | | |
| wH1 | 8 | #6 | 5'-8" | 68 | wH1 | 8 | #6 | 5'-8" | 68 | | |
| wH2 | 12 | #6 | 6'-10" | 123 | wH2 | 12 | #6 | 6'-10" | 123 | | |
| wU | 14 | #4 | 1'-7" | 15 | wU | 14 | #4 | 1'-7" | 15 | | |
| wV | 28 | #5 | 3'-4" | 97 | wV | 28 | #5 | 3'-6" | 102 | | |
| Reinforcing Steel | | | | Lb | 2,284 | Reinforcing Steel | | | | Lb | 2,305 |
| Class "C" Concrete | | | | CY | 10.9 | Class "C" Concrete | | | | CY | 10.9 |

- ① Quantities shown are for one Abutment only (with Approach Slab). With no Approach Slab, add 103 Lbs Total Reinforcing Steel for the following:
 2 ~ #5 Bars H (42'-9")
 2 ~ #5 Bars M1 (3'-2")
 2 ~ #5 Bars M2 (3'-6")
 Add the following amounts for concrete:
 14" slab thickness add 2.1 CY Class "C" Concrete.
 16" slab thickness add 2.4 CY Class "C" Concrete.
- ② Increase as required to maintain 3 3/4" from Finished Grade.
 ③ See Layout to determine if Approach Slab is present.
 ④ Use with 14" slab thickness.
 ⑤ Use with 16" slab thickness.
 ⑥ Omit Bars H and M if Approach Slab is present.
 ⑦ See standard CS-MD for Preformed Bituminous Fiber Material.

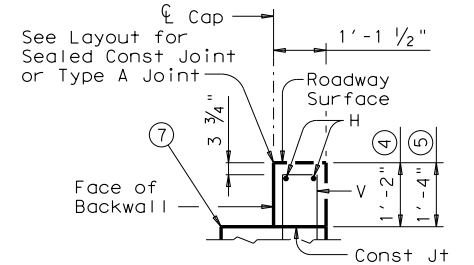

BACKWALL DETAIL ③
(Without Approach Slab)

GENERAL NOTES:
 Designed according to AASHTO LRFD Specifications. Details shown are for right forward skew. See layout for actual skew direction.
 All cap and wall reinforcing shall be Grade 60. Concrete strength f'c = 3,600 psi.
 Designed for normal embankment header slope of 3:1. See Layout for foundation size and length. See standard FD for foundation details and notes. See standard CS-MD for joint details and details not shown.
 Calculated Foundation Loads: 25 Tons/Pile. These abutment details may be used with standards CS-25-38, CS-50-38-30, CS-75-38-30 and CS-80-38-30 only.

HL93 LOADING

| | | | |
|--|-----------|---------------------------------|------------|
| | | Bridge Division Standard | |
| ABUTMENTS FOR C-I-P CONC SLAB SPANS (PILES) 38 FT ROADWAY 30° SKEW ACSP-38-30 | | | |
| FILE: acs18ste.dgn | DN: TxDOT | CK: TxDOT | DW: TxDOT |
| CONT: TxDOT | SECT: | JOB: | HIGHWAY: |
| REVISIONS: | DIST: | COUNTY: | SHEET NO.: |